

THE STATE OF NEW HAMPSHIRE
 DEPARTMENT OF TRANSPORTATION
CONSTRUCTION PLANS
FEDERAL AID PROJECT

STP-BRF-X-T-032-1(21)
 N.H. PROJECT NO. P-4370
 US 302

DESIGN DATA	
AVERAGE DAILY TRAFFIC 1998	11 570
AVERAGE DAILY TRAFFIC 2018	20 500
PERCENT OF TRUCKS	7.1
DESIGN SPEED	80 km/h
LENGTH OF PROJECT	1.2 km

SAMPLE PLANS
 DATE 31-DEC-1998

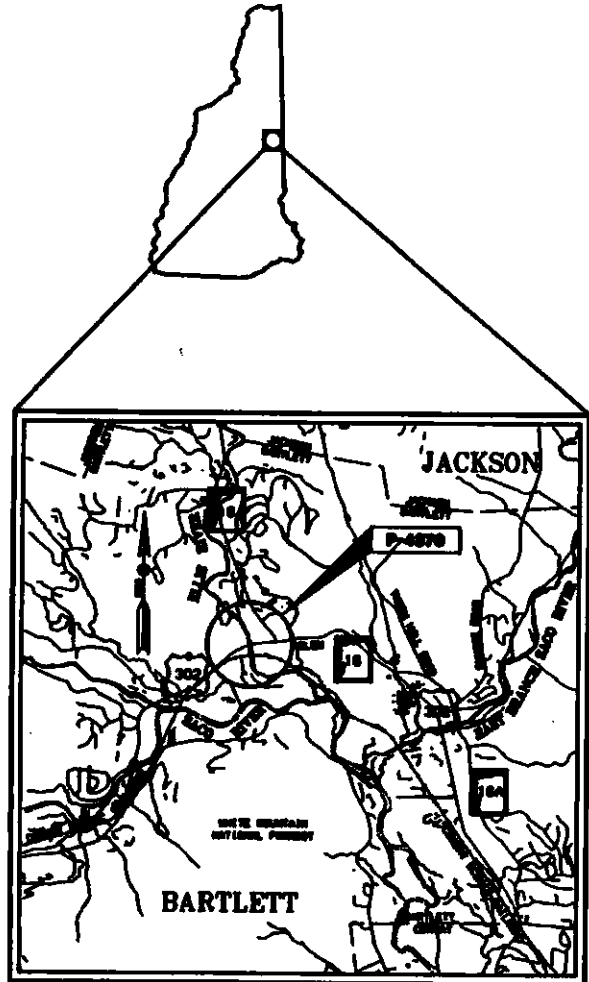

LOCATION MAP

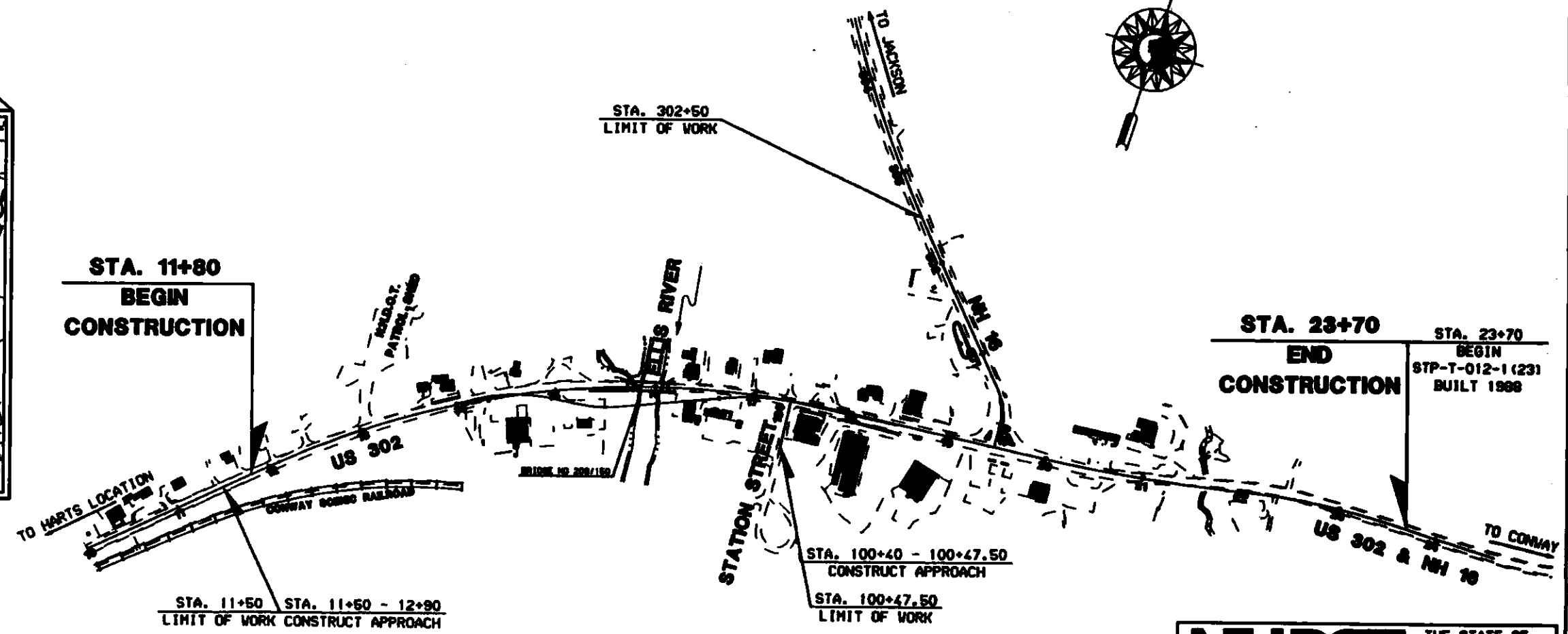

TOWN OF BARTLETT
 COUNTY OF CARROLL
 SCALE: 1:2500

METRIC

* NOTE: IF TOWN OR CITY FUNDING IS INVOLVED, INCLUDE OBJECT TITLE, MUN FOR ADDITIONAL SIGNATURE

NHDOT THE STATE OF NEW HAMPSHIRE DEPARTMENT OF TRANSPORTATION

RECOMMENDED FOR APPROVAL:

 DIRECTOR OF PROJECT DEVELOPMENT DATE

 ADMINISTRATOR, BUREAU OF MUNICIPAL HIGHWAYS DATE

APPROVED:

 ASSISTANT COMMISSIONER AND CHIEF ENGINEER DATE

U. S. DEPARTMENT OF TRANSPORTATION
 FEDERAL HIGHWAY ADMINISTRATION

APPROVED:

 DIVISION ADMINISTRATOR DATE

FEDERAL PROJECT NO.	STATE PROJECT NO.	SHEET NO.	TOTAL SHEETS
	P-4370	1	101

DESIGNED BY: R. MOON
 CHECKED BY: S. J. SMYTH
 DATE: 9/87
 DATE: 9/87

INDEX OF SHEETS

SHEET NO.	DESCRIPTION
1	TITLE PAGE
2	INDEX OF SHEETS & GENERAL NOTES
3	INDEX OF STANDARD PLANS
4,5	STANDARD SYMBOLS
	TYPICAL SECTIONS OF IMPROVEMENT
	SUMMARY OF QUANTITIES

GENERAL NOTES

- ① CONSTRUCT THIS PROJECT IN ACCORDANCE WITH NHDOT STANDARD SPECIFICATIONS DATED 1997, CURRENT STANDARD PLANS, SUPPLEMENTAL SPECIFICATIONS AND SPECIAL PROVISIONS INCLUDED IN THE PROPOSAL.
- ② HIGH TENSION OVERHEAD TRANSMISSION LINES ARE LOCATED THROUGHOUT THE PROJECT WITH CROSSINGS AT VARIOUS LOCATIONS AND RUNNING ALONG THE ROAD THROUGHOUT THE PROJECT EVEN ON REGULAR POLES. THE CONTRACTOR IS ADVISED THAT EXTREME CAUTION WILL BE REQUIRED IN THE OPERATION OF EQUIPMENT, ESPECIALLY CRANES AND PILE DRIVING EQUIPMENT.
- ③ REMOVE TOPSOIL FOR ITS TOTAL DEPTH WITHIN THE LIMITS OF THE SLOPE LINES. UNLESS OTHERWISE DIRECTED, STOCKPILE TOPSOIL AND USE IT ON THIS PROJECT AS NEEDED UNDER SECTION 641 - DAM AND/OR SECTION 647 - HUMUS.
- ④ REMOVAL OF EXISTING CONCRETE PAVEMENT WILL BE PAID UNDER ITEM 203.2 - ROCK EXCAVATION. THE BITUMINOUS PAVEMENT ABOVE THE CONCRETE WILL NOT BE PAID UNDER ITEM 203.2.
- ⑤ MODIFY SUPERELEVATION ON EXISTING CURVES BY THE USE OF A PAVEMENT LEVELING COURSE TO THE RATES INDICATED ON THE PLANS OR AS ORDERED.
- ⑥ EXISTING DELINEATORS AND WITNESS MARKERS THAT ARE REMOVED AND DETERMINED BY THE ENGINEER TO BE IN ACCEPTABLE CONDITION SHALL BE RESET (SUBSIDIARY). ADDITIONAL DELINEATORS AND WITNESS MARKERS ORDERED WILL BE PAID UNDER THE APPROPRIATE ITEMS OF THE CONTRACT.
- ⑦ NO EXISTING MONUMENTS, BOUNDS, OR BENCHMARKS SHALL BE DISTURBED WITHOUT FIRST MAKING PROVISIONS FOR RELOCATION.
- ⑧ PERFORM ALL WORK WITHIN THE EXISTING RIGHT-OF-WAY, UNLESS OTHERWISE SHOWN ON THE PLANS OR AS ORDERED BY THE ENGINEER.
- ⑨ REMOVE UNPROTECTED PROJECT MARKERS (SUBSIDIARY).
- ⑩ SURVEY DATA FOR THIS PROJECT WAS COLLECTED BY SDR AND THE FIELD NOTES CAN BE FOUND IN THE FIELD BOOK(S) _____. COORDINATES ARE NEW HAMPSHIRE STATE PLANE COORDINATES OF N.A.D. 1983 AND THE BEARINGS ARE GRID. ELEVATIONS ARE REFERENCED TO N.S.V.D. 929.

THE FOLLOWING GENERAL NOTES
WILL BE USED ON THIS PROJECT:

<input type="checkbox"/>	<input type="checkbox"/>	<input type="checkbox"/>	<input type="checkbox"/>	<input type="checkbox"/>	<input type="checkbox"/>	<input type="checkbox"/>	<input type="checkbox"/>	<input type="checkbox"/>	<input type="checkbox"/>	<input type="checkbox"/>	<input type="checkbox"/>
<input type="checkbox"/>	<input type="checkbox"/>	<input type="checkbox"/>	<input type="checkbox"/>	<input type="checkbox"/>	<input type="checkbox"/>	<input type="checkbox"/>	<input type="checkbox"/>	<input type="checkbox"/>	<input type="checkbox"/>	<input type="checkbox"/>	<input type="checkbox"/>
<input type="checkbox"/>	<input type="checkbox"/>	<input type="checkbox"/>	<input type="checkbox"/>	<input type="checkbox"/>	<input type="checkbox"/>	<input type="checkbox"/>	<input type="checkbox"/>	<input type="checkbox"/>	<input type="checkbox"/>	<input type="checkbox"/>	<input type="checkbox"/>

STATE OF NEW HAMPSHIRE			
DEPARTMENT OF TRANSPORTATION • BUREAU OF HIGHWAY DESIGN			
INDEX OF SHEETS AND GENERAL NOTES			
REVISION DATE	WINDOW NAME	.FIG FILENAME	
0-0-00	INDEX		
FEDERAL PROJECT NO.	STATE PROJECT NO.	SHEET NO.	TOTAL SHEETS

REVISION DATE	WINDOW NAME	.FIG FILENAME	FEDERAL PROJECT NO.	STATE PROJECT NO.	SHEET NO.	TOTAL SHEETS
0-0-00	INDEX					

GENERAL CULTURE

WETLANDS

ENGINEERING

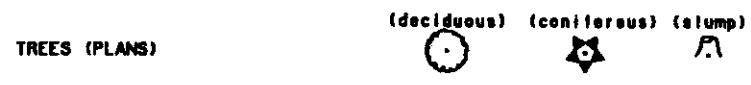
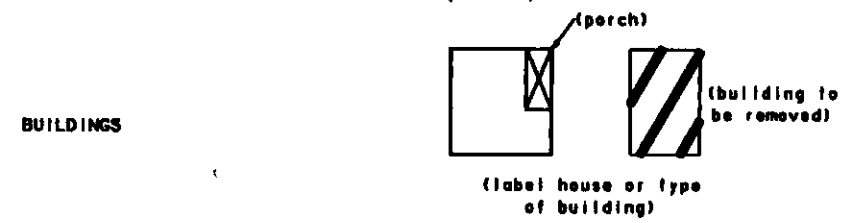
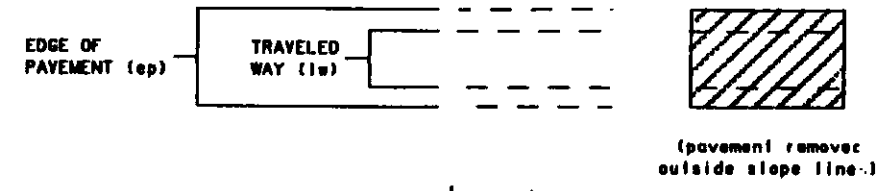

LEACH FIELD

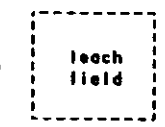

GAS PUMP



FUEL TANK (ABOVE GROUND)



SEPTIC TANK



GRAVE



ROCK OUTCROP



ORIGINAL GROUND (TYPICALS)

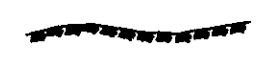

ROCK LINE (TYPICALS & SECTIONS ONLY)



STONE WALL

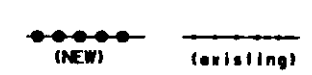

RETAINING WALL (LABEL TYPE)

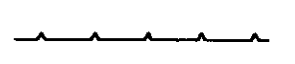

FENCE (BARBED WIRE)

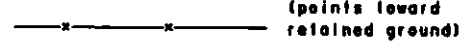

FENCE (OTHER)

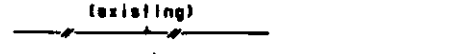

MAILBOX

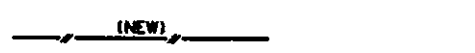

SATellite DISH ANTENNA

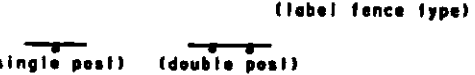

WETLAND DESIGNATION NUMBER



DELINEATED WETLAND

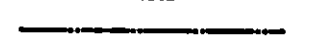

POTENTIAL WET AREA SYMBOL



CONSTRUCTION BASELINE



PC, PT, POT (ON CONST BASELINE)



PI (IN CONSTRUCTION BASELINES)



INTERSECTION OR EQUATION OF TWO LINES



ORIGINAL GROUND LINE (PROFILES AND CROSS-SECTIONS)

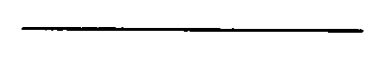

PROFILE GRADE LINE (PROFILES AND CROSS-SECTIONS)

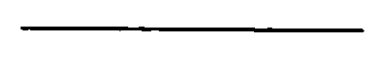

SLOPE LINE (FILL)



SLOPE LINE (CUT)



PROFILES AND CROSS SECTIONS:
ORIGINAL GROUND ELEVATION (LEFT)
FINISHED GRADE ELEVATION (RIGHT)

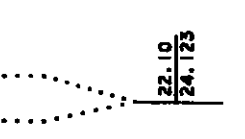

INTERSTATE NUMBERED HIGHWAY



UNITED STATES NUMBERED HIGHWAY



STATE NUMBERED HIGHWAY



BORING LOCATION



TEST PIT



STATE OF NEW HAMPSHIRE
DEPARTMENT OF TRANSPORTATION • BUREAU OF HIGHWAY DESIGN
STANDARD SYMBOLS

REVISION DATE	WINDOW NAME	.JWB FILENAME	FEDERAL PROJECT NO.	STATE PROJECT NO.	SHEET NO.	TOTAL SHEETS
8-8-88	SYTH					

DRAINAGE

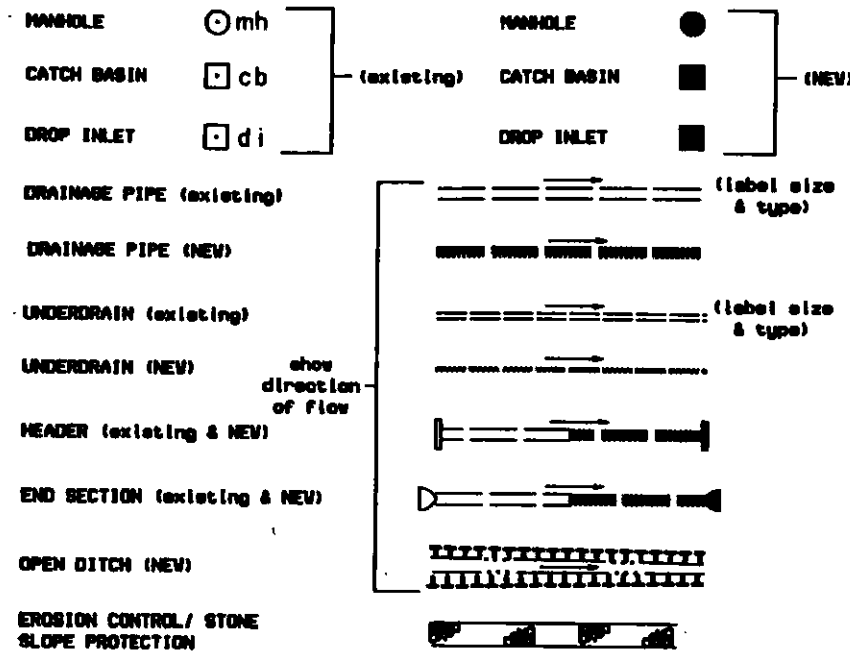

FLOODPLAIN / FLOODWAY

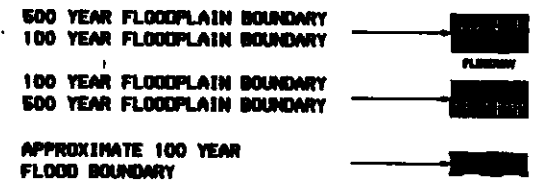

BOUNDARIES / RIGHT-OF-WAY

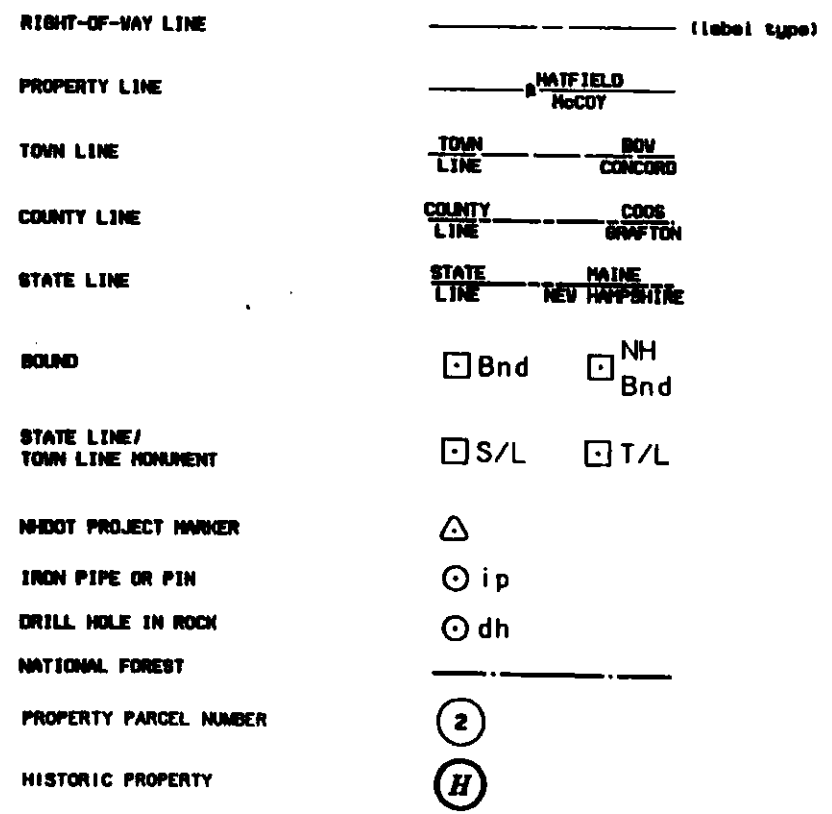

UTILITIES

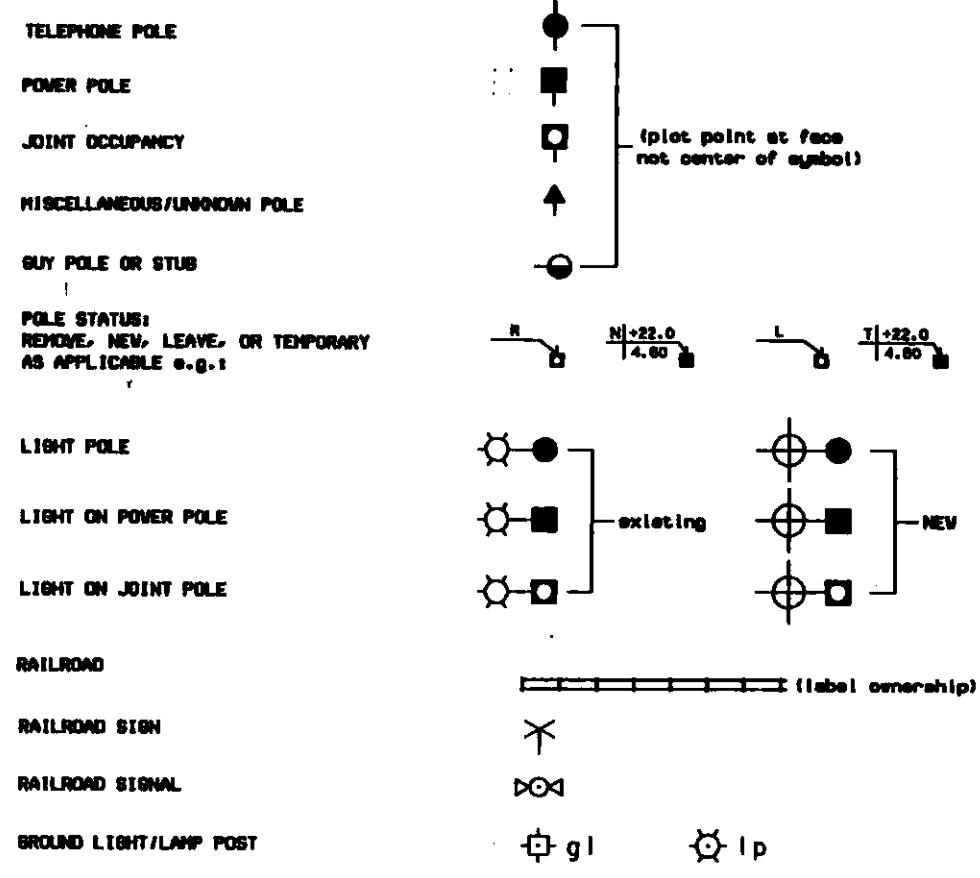

UNDERGROUND UTILITIES

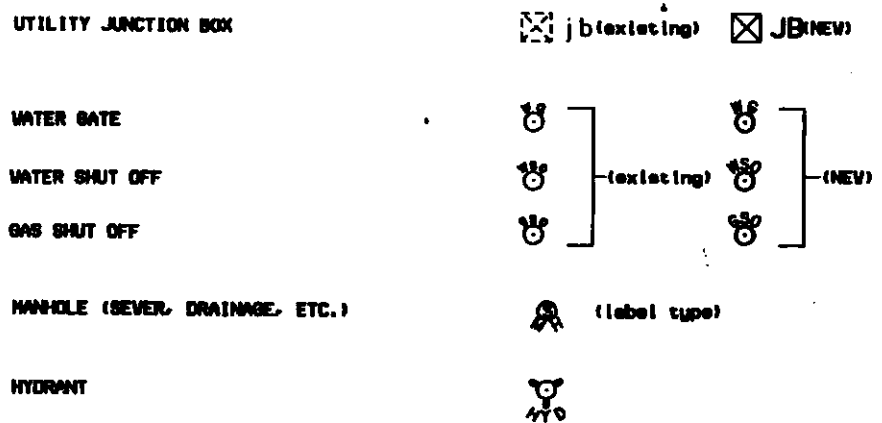
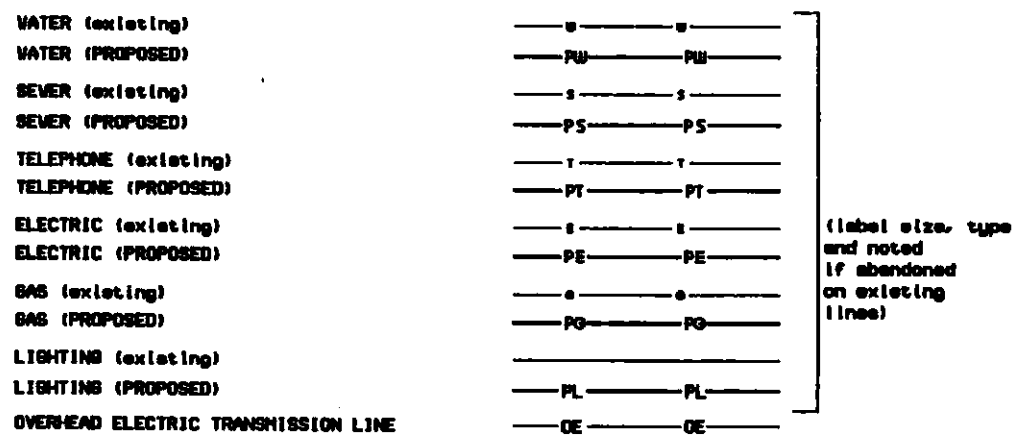



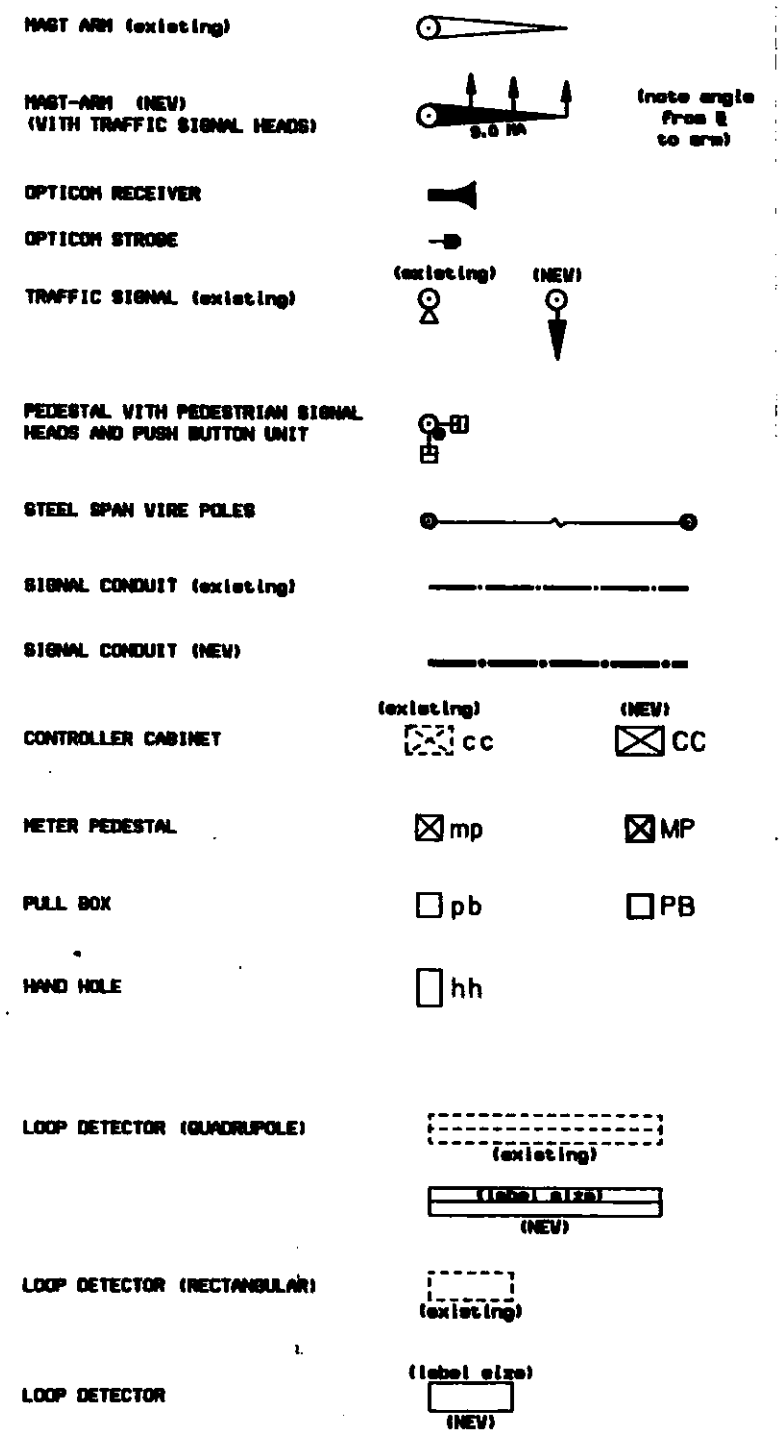







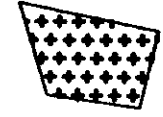

TRAFFIC SIGNALS





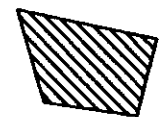



STATE OF NEW HAMPSHIRE						
DEPARTMENT OF TRANSPORTATION • BUREAU OF HIGHWAY DESIGN						
STANDARD SYMBOLS						
REVISION DATE	WINDOW NAME	FOR FILING	FEDERAL PROJECT NO.	STATE PROJECT NO.	SHEET NO.	TOTAL SHEETS
6-6-88	SYME					

WETLANDS











WETLAND DESIGNATION NUMBER	 PUB2E
WETLAND IMPACT LOCATION	
WETLAND MITIGATION DESIGNATION	
TEMPORARY IMPACT LOCATION	
DELINEATED WETLAND	
POTENTIAL WET AREA SYMBOL	
ORDINARY HIGH WATER	
TOP OF BANK	
TIDAL BUFFER ZONE	
TOP OF BANK AND ORDINARY HIGH WATER	
HIGHEST OBSERVABLE TIDAL LINE	
NH WETLANDS BUREAU NON-WETLAND IMPACT	
NH WETLANDS BUREAU AND ARMY CORPS OF ENGINEERS WETLAND IMPACT	
NH WETLANDS BUREAU AND ARMY CORPS OF ENGINEERS MITIGATION SITE	

RIGHT-OF-WAY













TEMPORARY ROW EASEMENT	
DRAINAGE/CHANNEL ROW EASEMENT	
OTHER ROW EASEMENT	
PERMANENT ROW TAKE	  

(removes the hatching or shading of the easement or take on the construction plans)

CONSTRUCTION PLAN NOTES

PROPERTY PARCEL NUMBER	
CLEARING & GRUBBING AREA (REFER TO SUMMARY SHEETS)	
HISTORIC PROPERTY	
GRANITE CURB MARK NUMBER (REFER TO SUMMARY SHEETS)	
BITUMINOUS CURB MARK NUMBER (REFER TO SUMMARY SHEETS)	
DRAINAGE NOTE	
FENCING NOTE (REFER TO SUMMARY SHEETS)	
GUARDRAIL NOTE (REFER TO SUMMARY SHEETS)	
SIGNALIZATION NOTE (REFER TO SUMMARY SHEETS)	
LIGHTING NOTE (REFER TO SUMMARY SHEETS)	
EROSION CONTROL NOTE (REFER TO SUMMARY SHEETS)	

PAVEMENT MARKINGS

THROUGH TRAFFIC ARROW	
LEFT TURN TRAFFIC ARROW	
RIGHT TURN TRAFFIC ARROW	
THROUGH-LEFT TURN TRAFFIC ARROW	
THROUGH-RIGHT TURN TRAFFIC ARROW	
RAILROAD SYMBOL	
BICYCLE LANE SYMBOL	
INTERNATIONAL SYMBOL OF ACCESSIBILITY	
PAVEMENT MARKING WORD "SCHOOL"	
PAVEMENT MARKING WORD "X-ING"	
PAVEMENT MARKING WORD "STOP"	
PAVEMENT MARKING WORD "AHEAD"	
PAVEMENT MARKING WORD "ONLY"	

PAVEMENT MARKING STRIPING NOTES (SPECIFY THE LINE WIDTH IN mm BEFORE NOTATION)

SINGLE BROKEN LINE (YELLOW)	xxSBLV
SINGLE SOLID LINE (YELLOW)	xxSSLY
DOUBLE SOLID LINE (YELLOW)	xxDSLY
SINGLE BROKEN LINE (WHITE)	xxSBLV
SINGLE SOLID LINE WHITE	xxSSLV

(NOTE: THIS SHEET SHOULD NOT BE INCLUDED IN THE CONTRACT PLANS SET. IT IS HERE MERELY AS A GUIDE TO A SUGGESTED FORMAT FOR THE VARIOUS LEGENDS THAT ARE NEEDED ON THE CONTRACT PLANS. EACH LEGEND SHOWN SHALL BE DRAWN ON THE APPROPRIATE PLAN SET (I.E. PAVEMENT MARKING LEGEND ON THE PAVEMENT MARKING PLANS, ETC.)

STATE OF NEW HAMPSHIRE		
DEPARTMENT OF TRANSPORTATION • BUREAU OF HIGHWAY DESIGN		
SUGGESTED NHDOT LEGEND FORMATS		
REVISION DATE	WINDOW NAME	.FIG FILENAME
6-8-98	LEGEND	STD-PLN

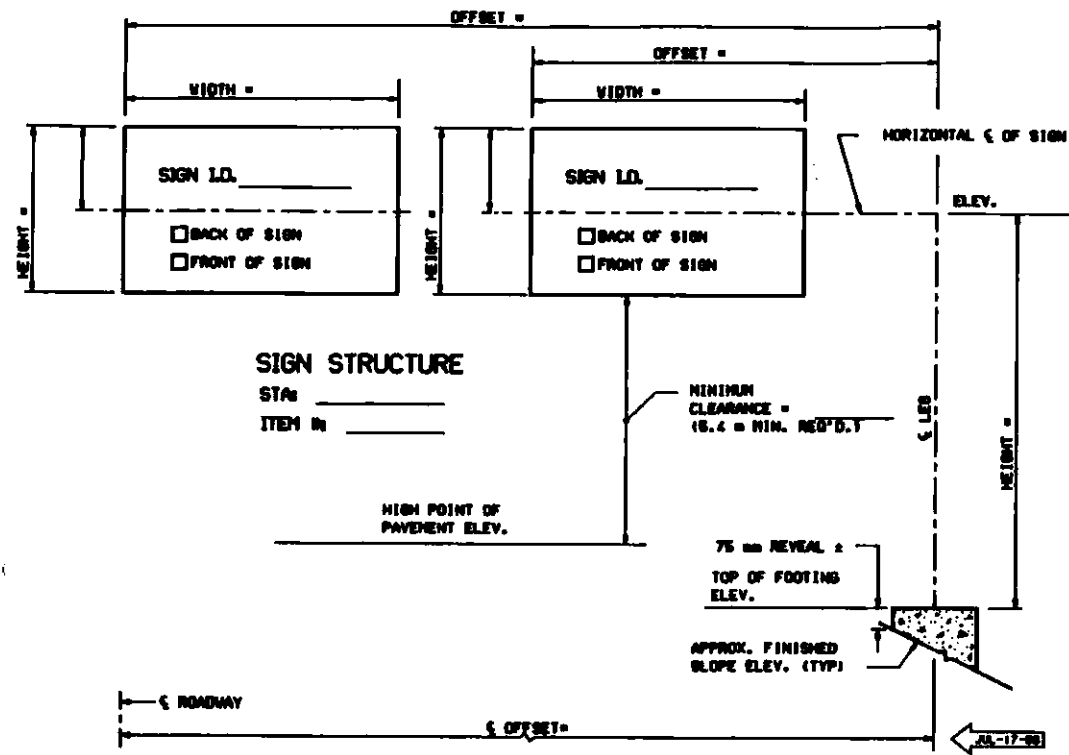

TYPE : ONE-LEG OVERHEAD CANTILEVER / 2 SIGNS

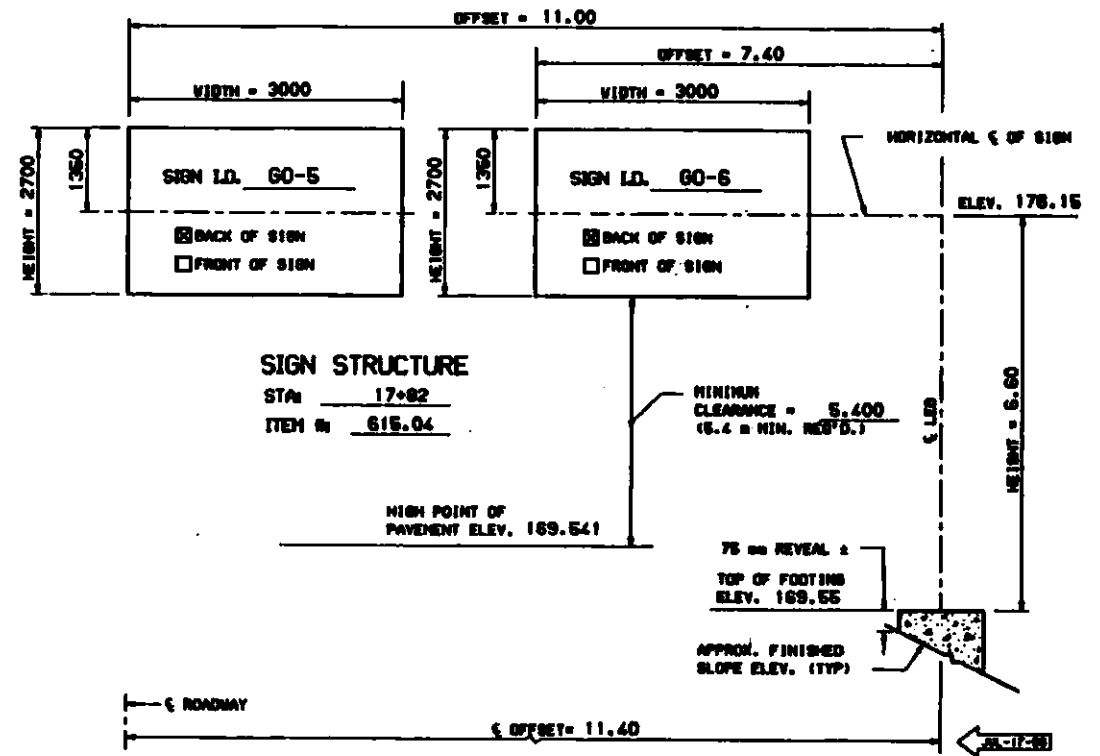

TYPE : ONE-LEG OVERHEAD CANTILEVER / 2 SIGNS

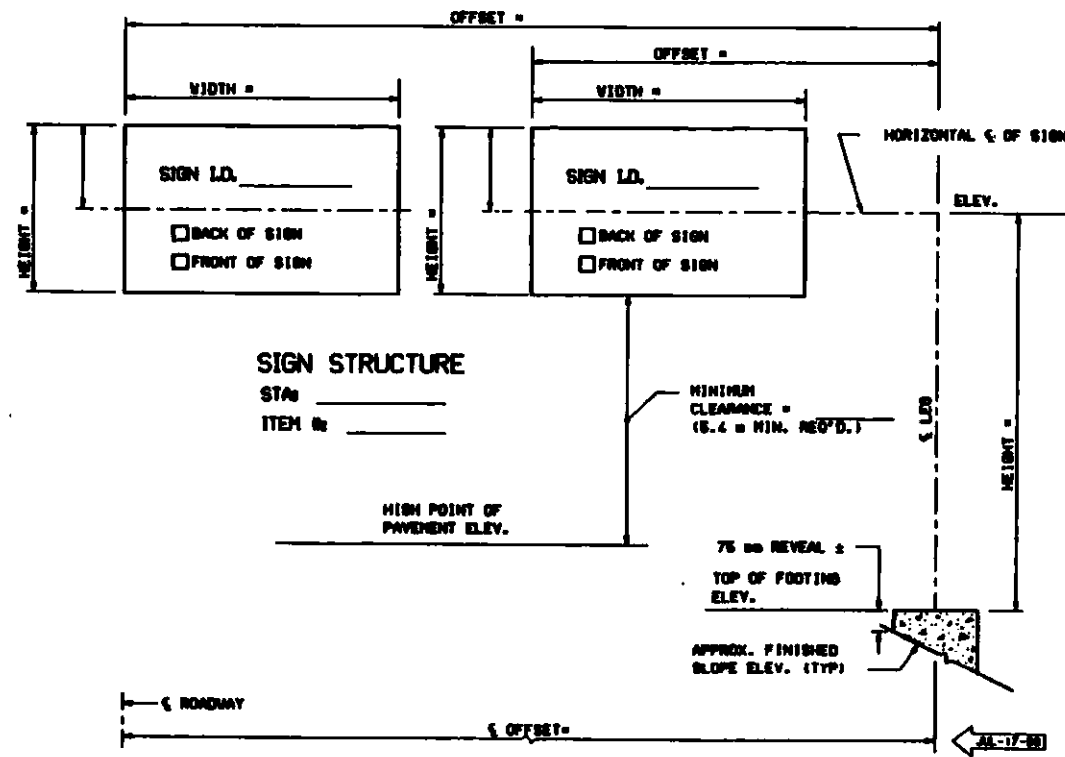

TYPE : ONE-LEG OVERHEAD CANTILEVER / 2 SIGNS

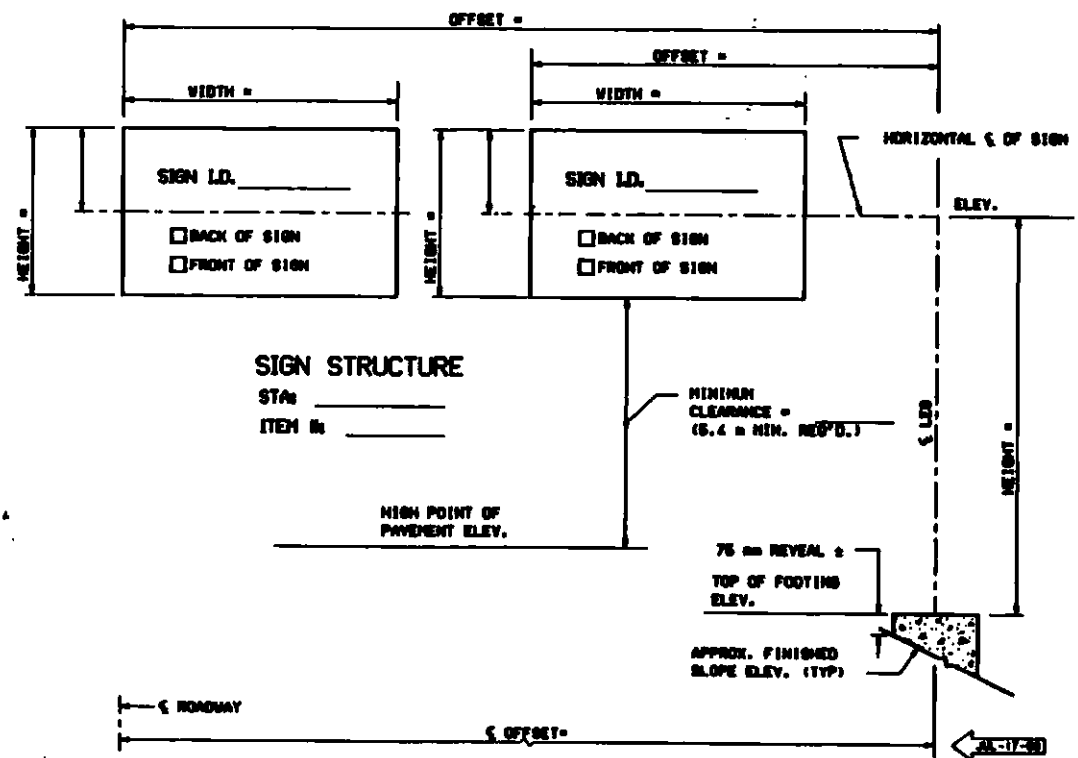

TYPE : ONE-LEG OVERHEAD CANTILEVER / 2 SIGNS

ITEM NO.	SHEET NO.	SIGN SIZE		TEXT	TEXT DIMENSIONS						REMARKS	ITEM NO.	SHEET NO.	SIGN SIZE		TEXT	TEXT DIMENSIONS						REMARKS						
		HEIGHT	WIDTH		LETTER HEIGHT	EVL. LINE NO. OR SYMBOL	ARROW	FRONTAL	NO. ROWS	SIGN AREA (m ²)				LETTER HEIGHT	EVL. LINE NO. OR SYMBOL		ARROW	FRONTAL	NO. ROWS	SIGN AREA (m ²)									
										NET AREA										TOTAL AREA	NET AREA	TOTAL AREA							
615 04	GO-1	2400	3000	EAST 302 SOUTH 16 Conway ←	333	250	300E/200E	600	300	1	7.20	7.20	575 x 575	SILVER/GREEN	615.022	GA-2	300 900	1800 1800	BRETTON WOODS CRAWFORD NOTCH NEXT RIGHT	150C 150C 150C	1	.54 1.62	2.16	2	2	SILVER/GREEN SILVER/BROWN			
615 04	GO-2	2400	3000	WEST 302 Barlett Twin Mts. →	333 333	250 250	300E/200E	600	300	1	7.20	7.20	575 x 575	SILVER/GREEN	615.02	GA-3	900	1500	JUNCTION 302 16	150C 600	1	1.35	1.35		1			SILVER/GREEN	
615 04	GO-3	2700	3000	WEST 302 Barlett Twin Mts. ↓	333 333	250 250	300E/200E	600	300	1	8.10	8.10	550 x 900	SILVER/GREEN	615.022	GA-4	300 900	1800 1800	BERLIN PINKHAM NOTCH NEXT RIGHT	150C 150C 150C	1 1	.54 1.62	2.16	2	2	SILVER/GREEN SILVER/BROWN			
615 04	GO-4	2400	3000	NORTH 16 Jackson Garban →	333 333	250 250	300E/200E	600	300	1	7.20	7.20	575 x 575	SILVER/GREEN	615.022	GA-5	900 300	1800 1800	♦ BRETTON WOODS ♦ CRAWFORD NOTCH ♦ ATTITASH SKI AREA	150C 150C 150C	150 x 175 150 x 175 150 x 175	1 1	1.62 .54	2.16	2	2	SILVER/BROWN GREEN/SILVER		
615 04	GO-5	2400	3000	NORTH 16 Jackson Garban ←	333 333	250 250	300E/200E	600	300	1	7.20	7.20	575 x 575	SILVER/GREEN	615.02	GA-4	900	1200	JUNCTION 16	150C 600	300	1	1.00	1.00		1			GREEN/SILVER
615 04	GO-6	2700	3000	EAST SOUTH 302 16 Conway Portland, Me. ↓	333 333	250 250	300E/200E	600	300	1	8.10	8.10	550 x 900	SILVER/GREEN	<p align="center">GENERAL NOTES</p> <p>1. ALL GO & GA SERIES SIGNS SHALL HAVE FLAT SHEET DEMOUNTABLE TEXT AND BORDER COVERED WITH TYPE III SILVER SHEETING. BACKGROUND SHALL BE TYPE III GREEN, UNLESS OTHERWISE SPECIFIED. ALL OTHER GUIDE SIGNS SHALL HAVE TYPE III SILVER TEXT AND BORDER WITH TYPE I BACKGROUND SHEETING, UNLESS OTHERWISE SPECIFIED. THERE SHALL BE NO GAPS IN THE BORDER ON THE MAIN SIGN OF GO & GA SERIES SIGNS WITH THE EXIT PANELS.</p> <p>2. ALL REGULATORY AND WARNING SIGNS SHALL HAVE TYPE I BACKGROUND SHEETING, UNLESS OTHERWISE SPECIFIED.</p> <p>3. ALL SHEETING SHALL CONFORM TO AASHTO M288 (ASTM D 4956).</p> <p>4. SHEETING SPECIFICALLY INTENDED FOR USE ON CONSTRUCTION SIGNS SHALL NOT BE PERMITTED.</p> <p>5. ALL GO & GA SERIES PLANK SIGNS SHALL CONTAIN THE SIZE AND DATE OF MANUFACTURE, LOCATED IN THE LOWER LEFT CORNER OF THE FRONT FACE. THESE LETTERS AND NUMBERS SHALL BE 50 mm NON-REFLECTIVE WHITE (I.E., 3-98 3.0 x 4.5 m).</p> <p>6. REFER TO THE STANDARD HIGHWAY SIGNS MANUAL AS PUBLISHED BY THE USDOT-FHWA FOR EXACT DETAILS OF BORDERS, ETC.</p> <p>7. ALL DIMENSIONS ARE IN MILLIMETERS OR METERS. WHOLE NUMBERS INDICATE MILLIMETERS, DECIMAL NUMBERS INDICATE METERS, UNLESS OTHERWISE NOTED.</p>														
615 02	GA-1	900	1200	JUNCTION 302		150C		600	300	1	1.00	1.00		SILVER/GREEN															

METRIC

SAMPLE PLAN
Dec. 31, 1998

STATE OF NEW HAMPSHIRE
DEPARTMENT OF TRANSPORTATION BUREAU OF HIGHWAY DESIGN
GUIDE SIGNS

ENCL. SHEET NAME	ENCL. FILE NAME	STATE PROJECT NO.	FEDERAL PROJECT NO.	SHEET NO.	TOTAL SHEETS
	01825134HARDWAREMATERIALS.DWG	P-4970			

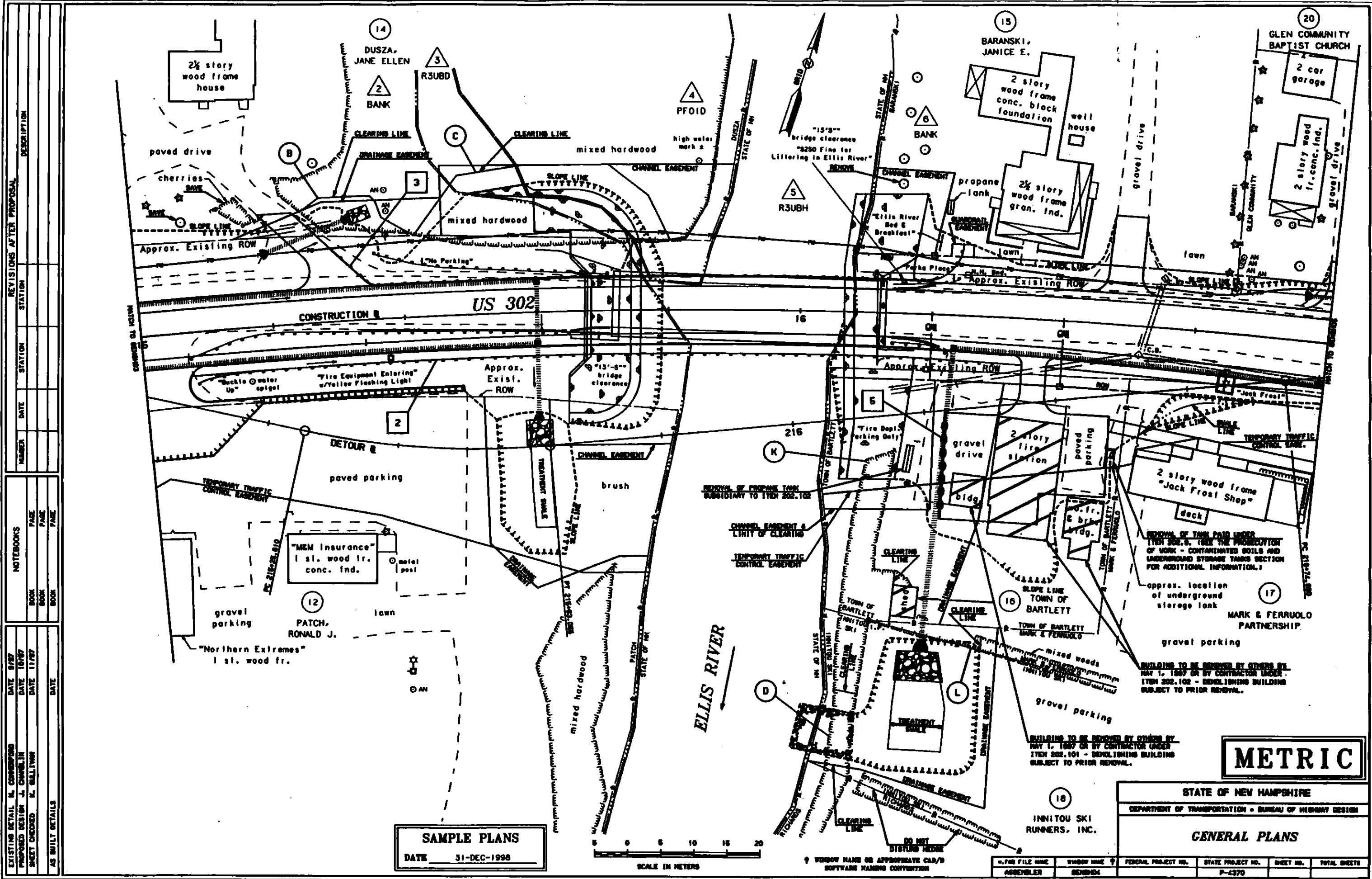

REVISIONS AFTER PROPOSAL	NUMBER	DATE	STATION	DESCRIPTION
NOTEBOOKS	BOOK	PAGE		
	BOOK	PAGE		
	BOOK	PAGE		
EXISTING DETAIL	DATE	BY		
	DATE	BY		
	DATE	BY		
PROPOSED DESIGN	DATE	BY		
	DATE	BY		
	DATE	BY		
SHEET CHECKED	DATE	BY		
	DATE	BY		
	DATE	BY		
AS BUILT DETAILS	DATE	BY		
	DATE	BY		
	DATE	BY		

SAMPLE PLANS
DATE 31-DEC-1998

SCALE IN METERS
0 5 10 15 20

↑ WINDOW NAME OR APPROPRIATE CAD/D SOFTWARE NAMING CONVENTION

FILE NAME	WINDOW NAME	FEDERAL PROJECT NO.	STATE PROJECT NO.	SHEET NO.	TOTAL SHEETS
ASSEMBLER	GENR04		F-4370		

METRIC

STATE OF NEW HAMPSHIRE
DEPARTMENT OF TRANSPORTATION - BUREAU OF HIGHWAY DESIGN
GENERAL PLANS

REVISIONS AFTER PROPOSAL
 STATION
 DATE
 NUMBER
 NOTESBOOKS
 DATE 8/87
 PROPOSED DESIGN J. GARDININ
 SHEET CHECKED M. SULLIVAN
 AS BUILT DETAILS
 DATE 10/87
 DATE 11/87

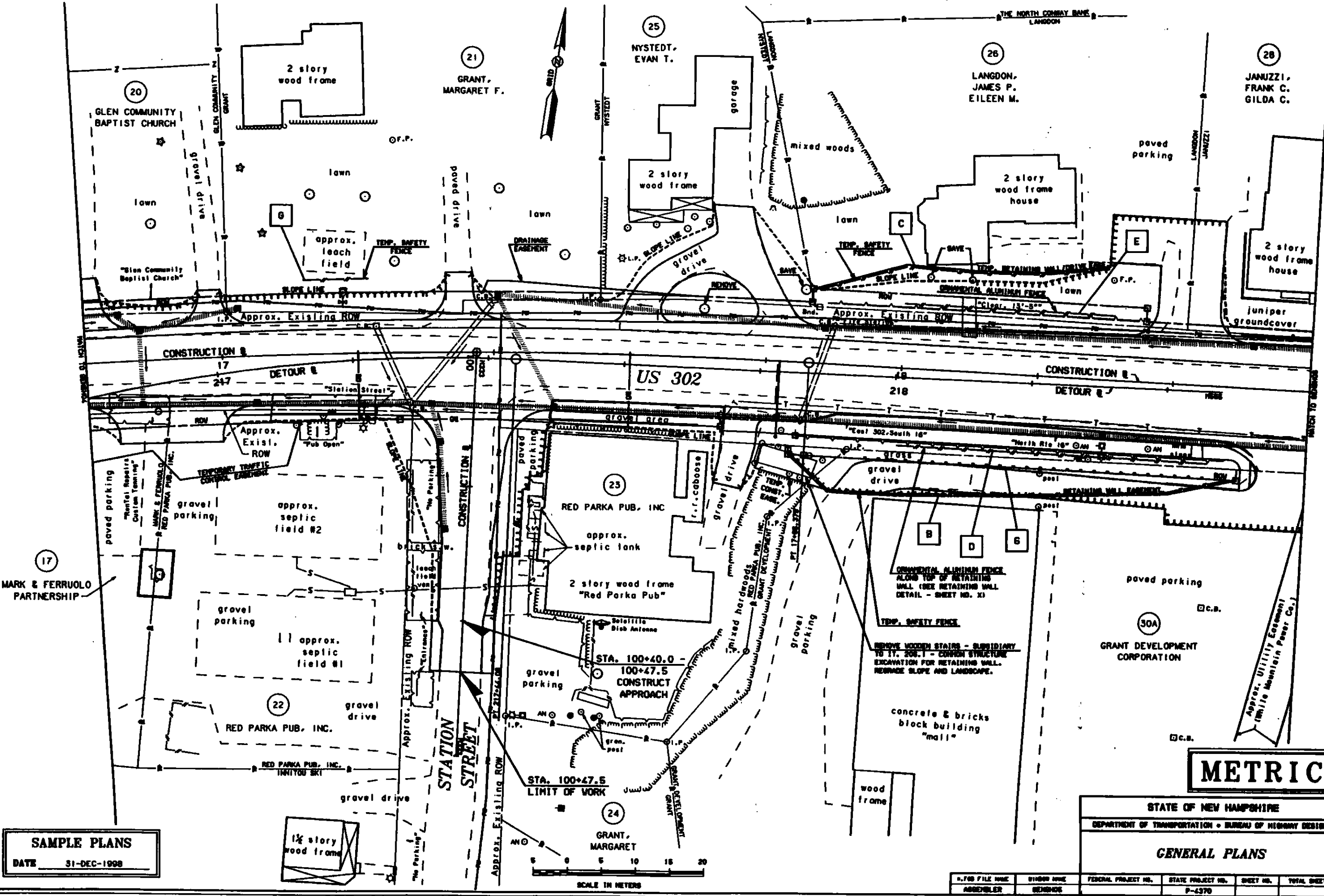

SAMPLE PLANS
 DATE 31-DEC-1998

METRIC

STATE OF NEW HAMPSHIRE
 DEPARTMENT OF TRANSPORTATION • BUREAU OF HIGHWAY DESIGN
GENERAL PLANS

FILE NAME	DRAWING NAME	FEDERAL PROJECT NO.	STATE PROJECT NO.	SHEET NO.	TOTAL SHEETS
ASSEMBLER	REVISIONS		P-4970		

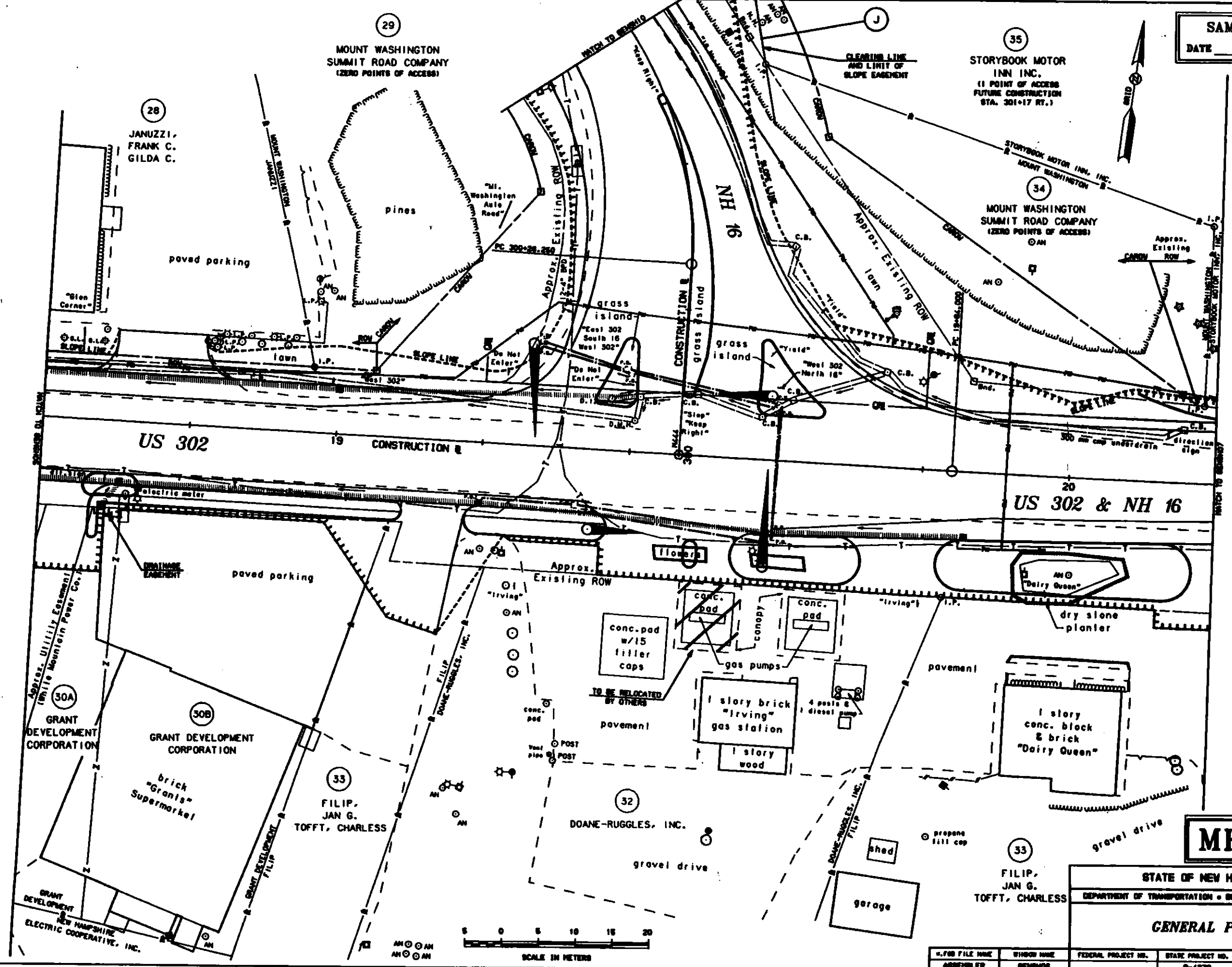

REVISIONS AFTER PROPOSAL	
NUMBER	DESCRIPTION

NOTESBOOKS	
BOOK	PAGE

EXISTING DETAIL	DATE	BY

METRIC

STATE OF NEW HAMPSHIRE
DEPARTMENT OF TRANSPORTATION • BUREAU OF HIGHWAY DESIGN
GENERAL PLANS

FILE NAME	OWNER NAME	FEDERAL PROJECT NO.	STATE PROJECT NO.	SHEET NO.	TOTAL SHEETS

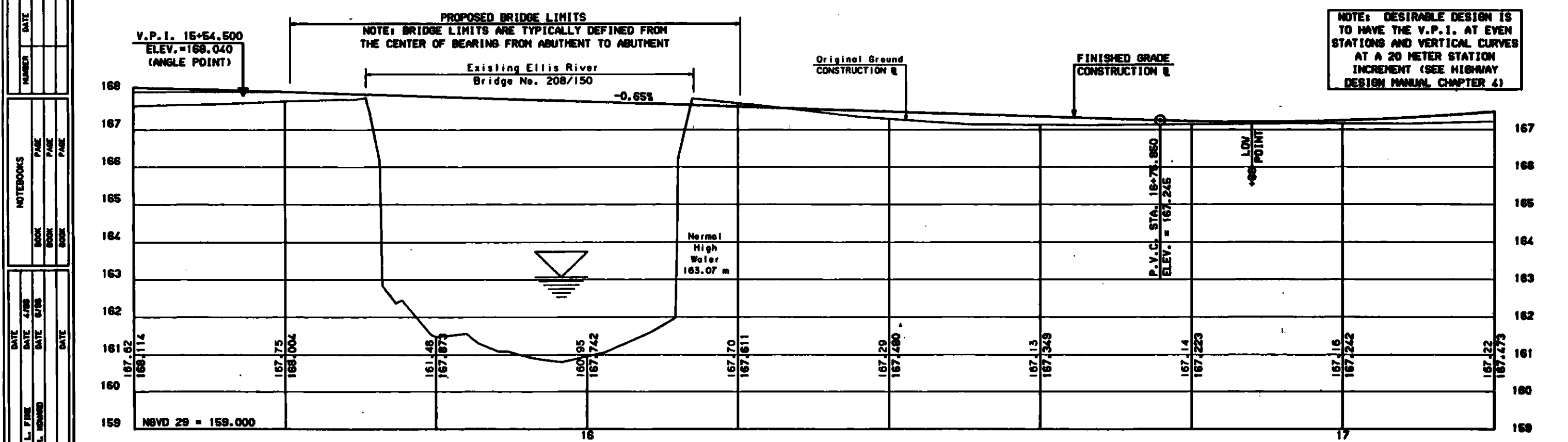
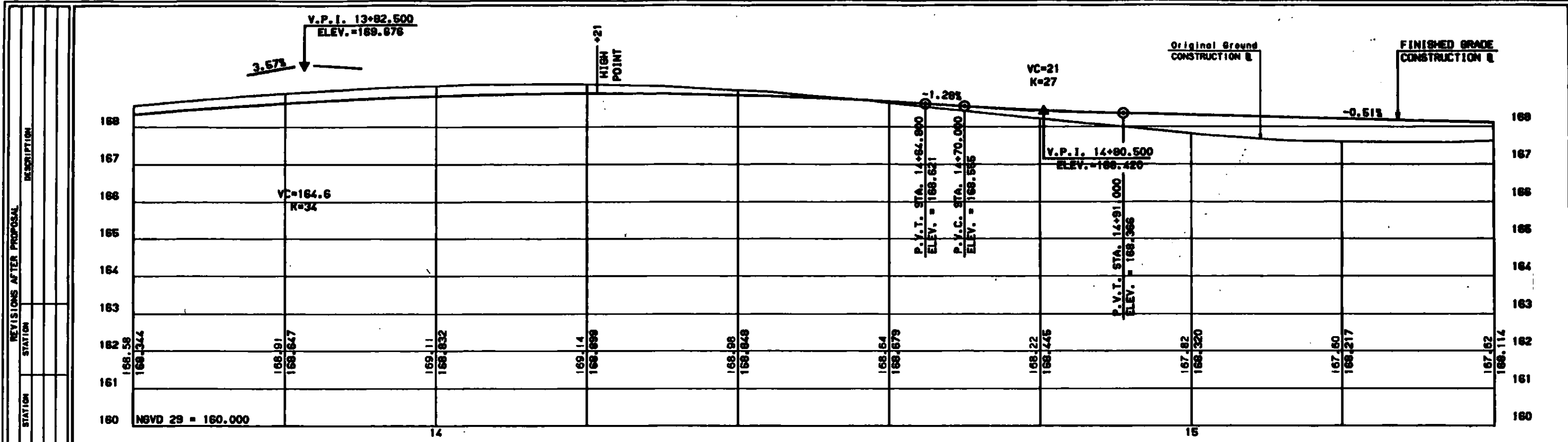

NOTE: DESIRABLE DESIGN IS TO HAVE THE V.P.I. AT EVEN STATIONS AND VERTICAL CURVES AT A 20 METER STATION INCREMENT (SEE HIGHWAY DESIGN MANUAL CHAPTER 4)

EXISTING DETAIL		DATE		DATE		DATE	
PROPOSED DESIGN		L. FINE		4/08			
SHEET CHECKED		R. HOWARD		8/08			
AS BUILT DETAILS		DATE		DATE		DATE	
REVISIONS AFTER PROPOSAL		NUMBER	DATE	STATION	DESCRIPTION	STATION	DESCRIPTION
NOTEBOOKS		BOOK	PAGE	BOOK	PAGE	BOOK	PAGE

SCALE:
1:250 HORIZ.
1:50 VERT.

SAMPLE PLANS
DATE 31-DEC-1998

METRIC

STATE OF NEW HAMPSHIRE				
DEPARTMENT OF TRANSPORTATION • BUREAU OF HIGHWAY DESIGN				
PROFILE US 302				
WISDOM NAME	JOB FILENAME	FEDERAL PROJECT NO.	STATE PROJECT NO.	SHEET NO.
PH111-2	PROFILES		P-4329	
TOTAL SHEETS				

EXISTING DETAIL		DATE		DATE		DATE		DATE		DATE	
PROPOSED DESIGN		L. FINE	DATE	L. FINE	DATE	L. FINE	DATE	L. FINE	DATE	L. FINE	DATE
SHEET CHECKED		M. HOSKINS	DATE	M. HOSKINS	DATE	M. HOSKINS	DATE	M. HOSKINS	DATE	M. HOSKINS	DATE
AS BUILT DETAILS		DATE		DATE		DATE		DATE		DATE	
REVISIONS AFTER PROPOSAL		NUMBER	DATE	STATION	STATION	STATION	STATION	STATION	STATION	STATION	DESCRIPTION
NOTEBOOKS		BOOK	PAGE	BOOK	PAGE	BOOK	PAGE	BOOK	PAGE	BOOK	PAGE

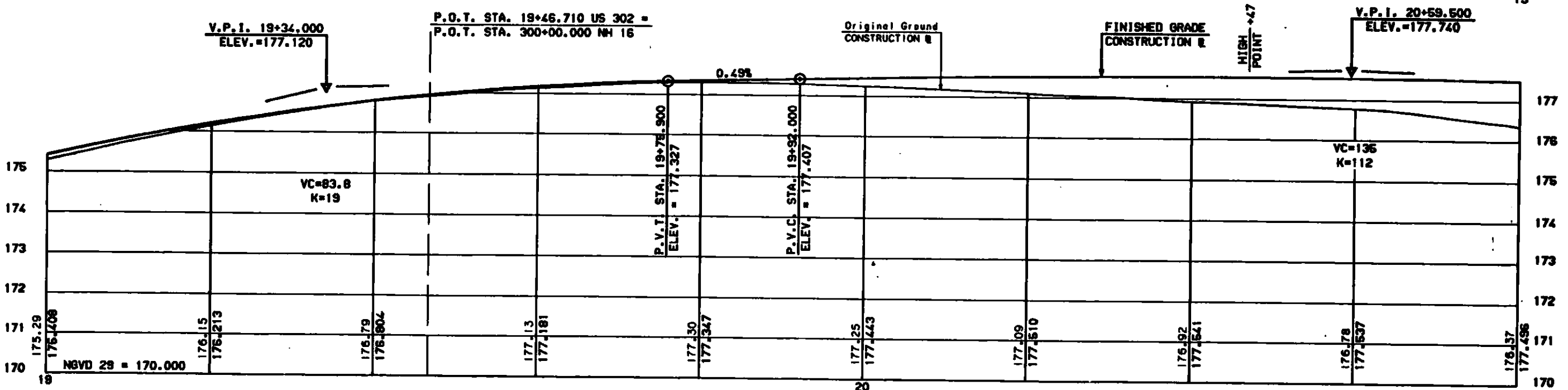
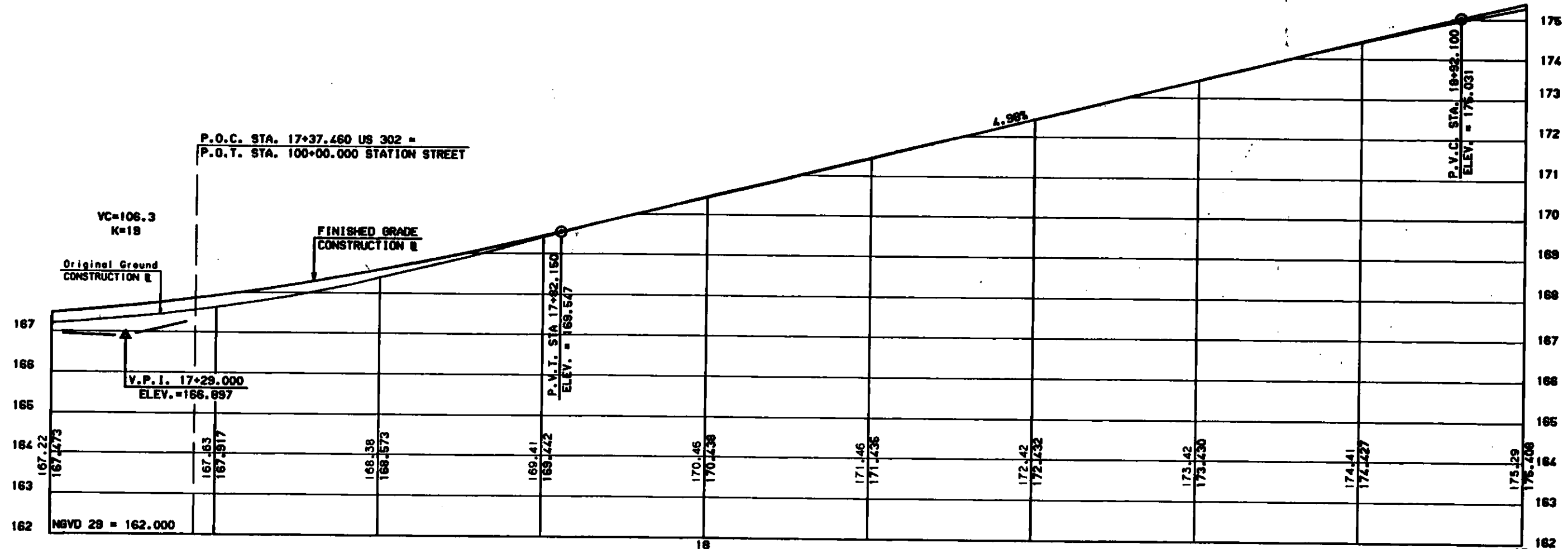

SCALE:
1:250 HORIZ.
1:50 VERT.

SAMPLE PLANS
DATE 31-DEC-1998

METRIC

STATE OF NEW HAMPSHIRE
DEPARTMENT OF TRANSPORTATION • BUREAU OF HIGHWAY DESIGN

PROFILE US 302

WINDOW NAME	.PDS FILENAME	FEDERAL PROJECT NO.	STATE PROJECT NO.	SHEET NO.	TOTAL SHEETS
PR1111-3	PROFILES		P-4378		

CURVE NO. 2 -
 U.S. RTE. 302 DETOUR
 PI=215+44.470
 N=178961.860
 E=338621.868
 T=18.864 m
 R=125.000 m
 L=37.445 m
 E=1.415 m

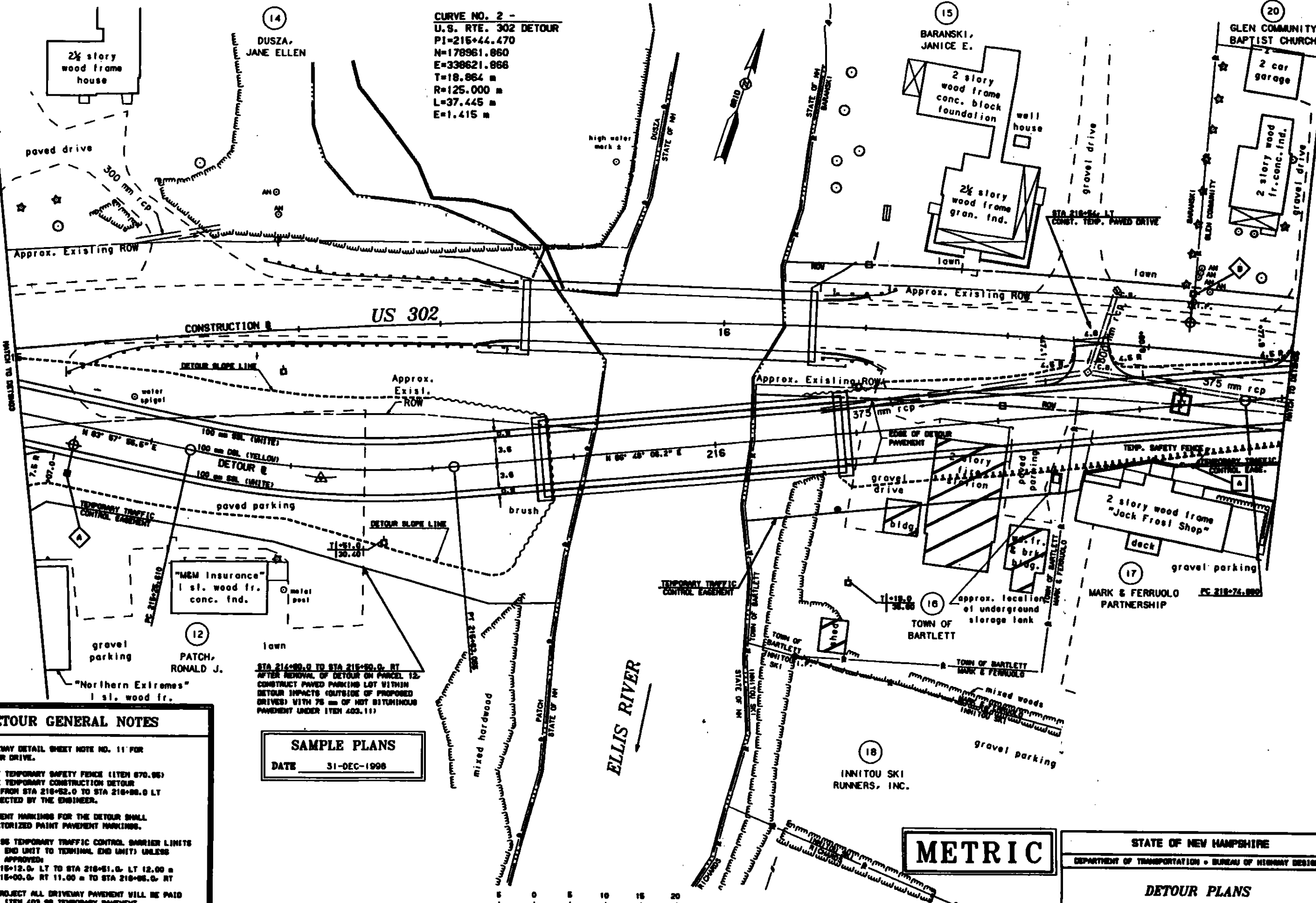

DETOUR GENERAL NOTES

- SEE DRIVEWAY DETAIL SHEET NOTE NO. 11 FOR THE DETOUR DRIVE.
- CONSTRUCT TEMPORARY SAFETY FENCE (ITEM 670.06) ALONG THE TEMPORARY CONSTRUCTION DETOUR EMBANKMENT FROM STA 218+82.0 TO STA 218+86.0 LT OR AS DIRECTED BY THE ENGINEER.
- ALL PAVEMENT MARKINGS FOR THE DETOUR SHALL BE REFLECTORIZED PAINT PAVEMENT MARKINGS.
- ITEM 606.96 TEMPORARY TRAFFIC CONTROL BARRIER LIMITS (TERMINAL END UNIT TO TERMINAL END UNIT) UNLESS OTHERWISE APPROVED:
 STA 218+12.0 LT TO STA 218+51.0 LT 12.00 m
 STA 218+00.0 RT 11.00 m TO STA 218+05.0 RT
- ON THIS PROJECT ALL DRIVEWAY PAVEMENT WILL BE PAID FOR UNDER ITEM 403.98 TEMPORARY PAVEMENT.

SAMPLE PLANS

DATE 31-DEC-1998

STA 214+80.0 TO STA 215+80.0 RT
 AFTER REMOVAL OF DETOUR ON PARCEL 12
 CONSTRUCT PAVED PARKING LOT WITHIN
 DETOUR IMPACTS (OUTSIDE OF PROPOSED
 DRIVES) WITH 75 mm OF HOT BITUMINOUS
 PAVEMENT UNDER (ITEM 403.11)

EXISTING DETAIL	K. CHAMBERLAIN	DATE	8/87
PROPOSED DESIGN	J. CHAMBERLAIN	DATE	10/97
SHEET CHECKED	K. SULLIVAN	DATE	11/97
AS BUILT DETAILS		DATE	

REVISIONS AFTER PROPOSAL	STATION	DATE	DESCRIPTION

NOTEBOOKS	PAGE
BOOK	BOOK
BOOK	BOOK
BOOK	BOOK

METRIC

STATE OF NEW HAMPSHIRE			
DEPARTMENT OF TRANSPORTATION • BUREAU OF HIGHWAY DESIGN			
DETOUR PLANS			
FEDERAL PROJECT NO.	STATE PROJECT NO.	SHEET NO.	TOTAL SHEETS
	P-4370		

† WINDOW NAME OR APPROPRIATE CAD/D SOFTWARE NAMING CONVENTION

ASBUILDER	DETDWG
-----------	--------

EXISTING DETAIL	N. COMBERG	DATE	9/87
PROPOSED DESIGN	J. CHAMBLIN	DATE	10/87
SHEET CHECKED	R. SALLIWAH	DATE	11/87
AS BUILT DETAILS		DATE	

REVISIONS AFTER PROPOSAL	
NUMBER	DESCRIPTION

NOTEBOOKS	
BOOK	PAGE

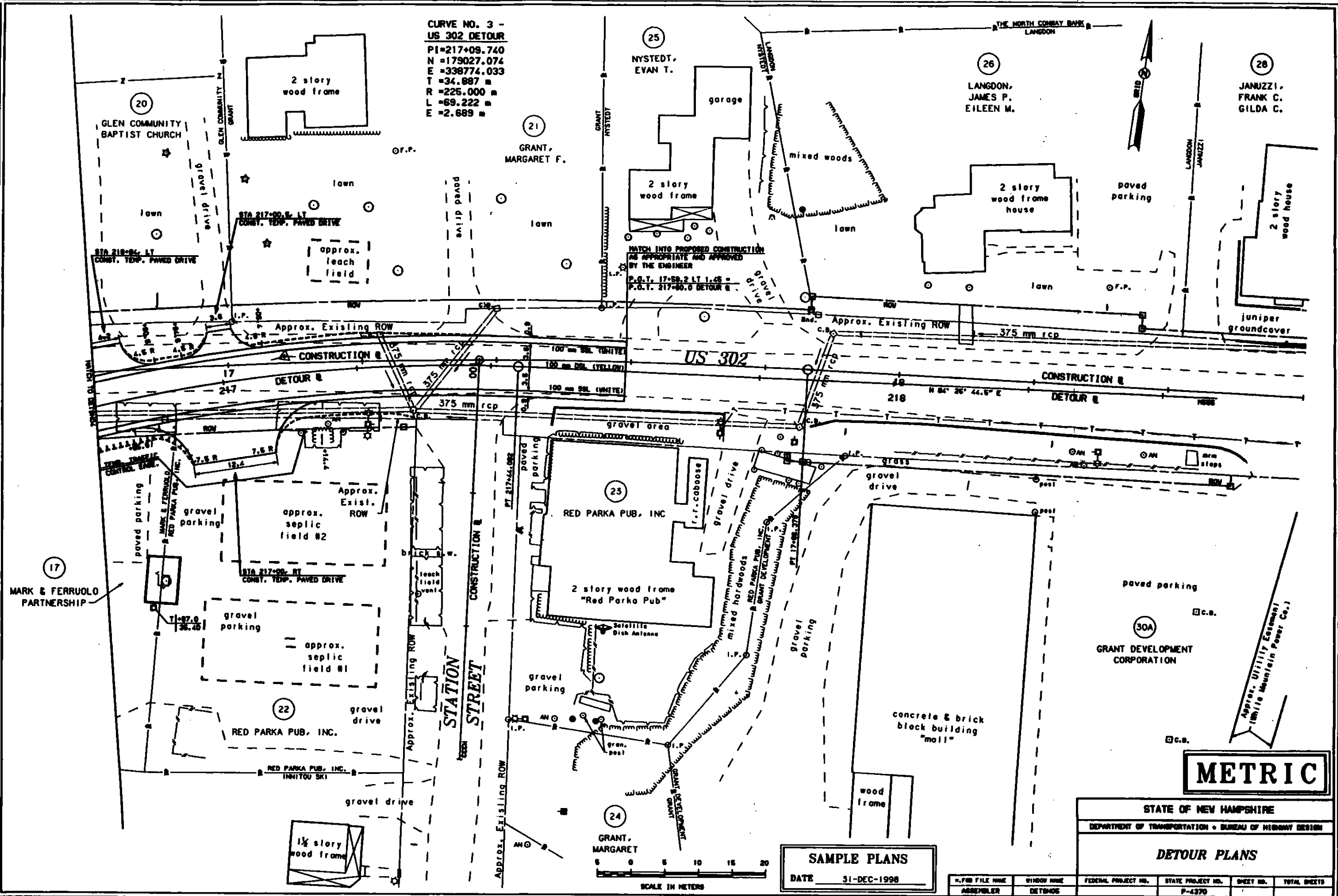

EXISTING DETAIL		DATE		DATE		DATE	
PROPOSED DESIGN	C. FINE	DATE	4/98	DATE	4/98	DATE	4/98
SHEET CHECKED	N. HOWARD	DATE	6/98	DATE	6/98	DATE	6/98
AS BUILT DETAILS		DATE		DATE		DATE	
NOTESBOOKS		PAGE		PAGE		PAGE	
BOOK	BOOK	BOOK	BOOK	BOOK	BOOK	BOOK	BOOK
REVISIONS AFTER PROPOSAL		STATION		STATION		STATION	
NUMBER	DATE	NUMBER	DATE	NUMBER	DATE	NUMBER	DATE

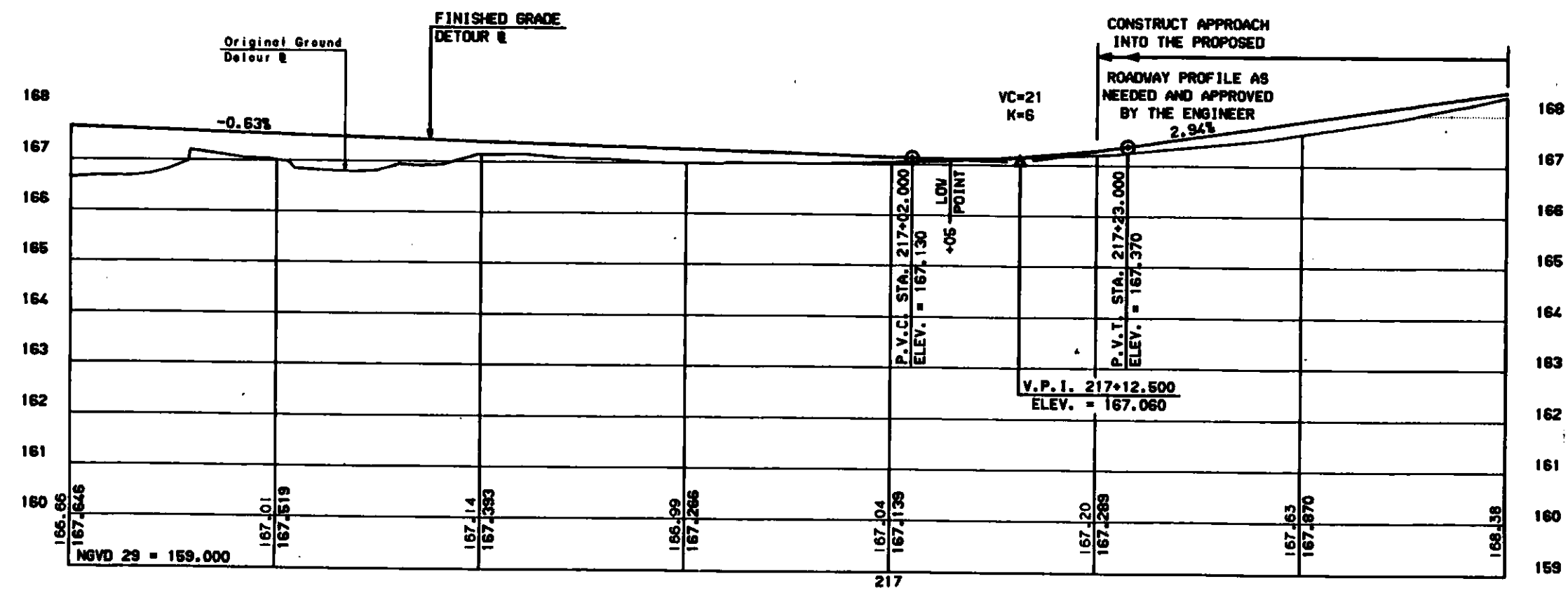
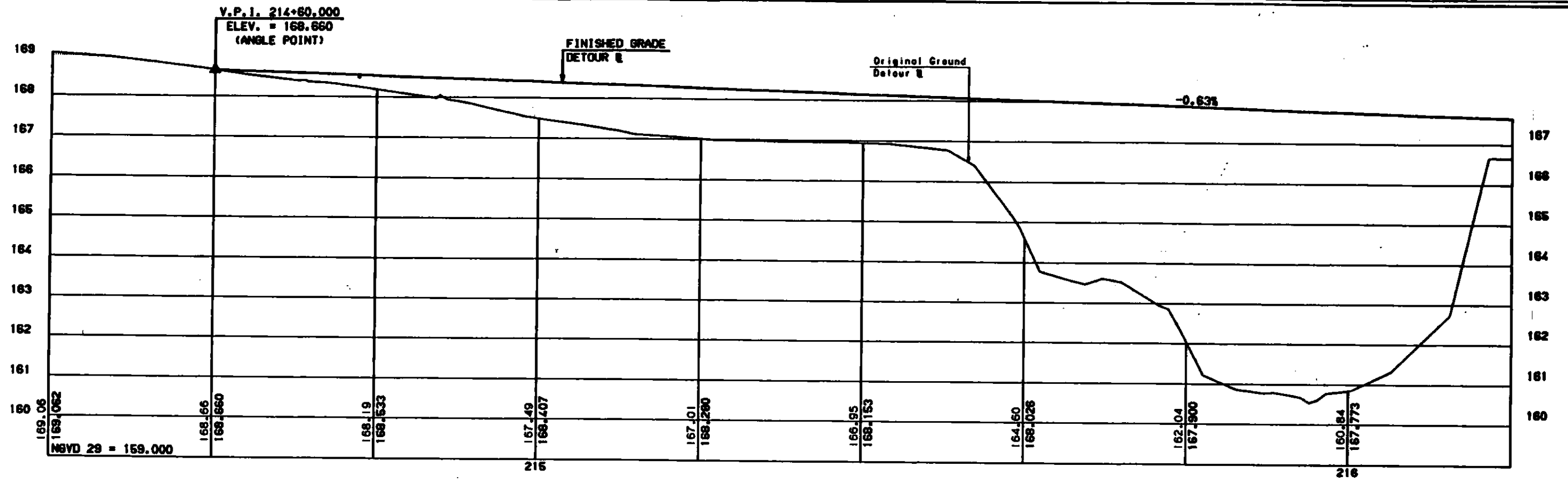

SAMPLE PLANS
DATE 31-DEC-1998

SCALE:
1:250 HORIZ.
1:50 VERT.

METRIC

STATE OF NEW HAMPSHIRE
DEPARTMENT OF TRANSPORTATION • BUREAU OF HIGHWAY DESIGN
US 302 DETOUR PROFILE

WINDOW NAME	.JOB FILENAME	FEDERAL PROJECT NO.	STATE PROJECT NO.	SHEET NO.	TOTAL SHEETS
DET-PROP	PROFILES		P-4370		

SAMPLE PLANS
DATE 31-DEC-1998

524|5|nhcecop|0|508a

REVISIONS AFTER PROPOSAL	NUMBER	DATE	STATION	DESCRIPTION
NOTEBOOKS	BOOK	PAGE		
	BOOK	PAGE		
	BOOK	PAGE		
EXISTING DETAIL	DATE	BY		
	DATE	BY		
	DATE	BY		
AS BUILT DETAILS	DATE	BY		
	DATE	BY		
	DATE	BY		

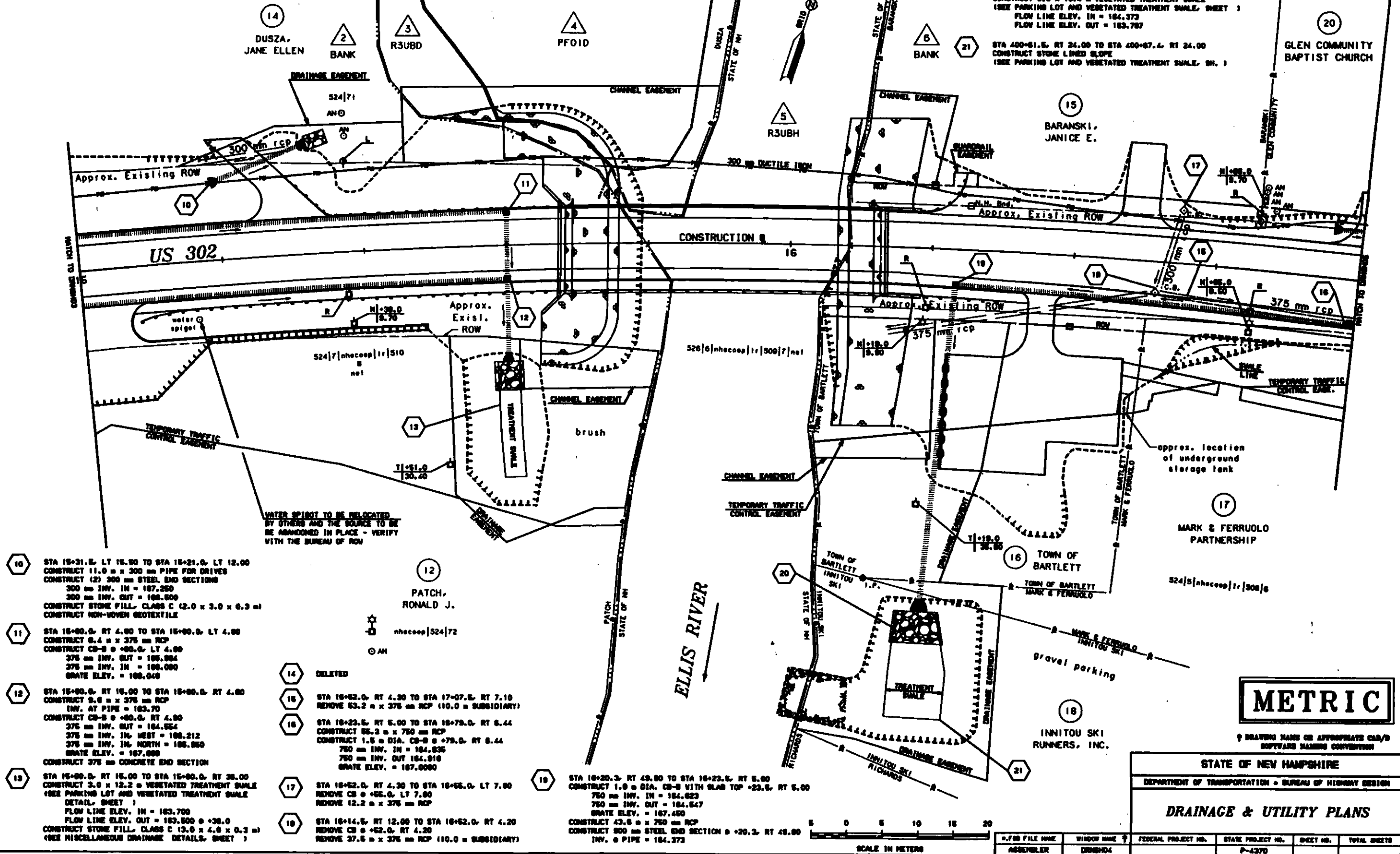

- 10** STA 15+31.0 - LT 15.00 TO STA 15+21.0 - LT 12.00
CONSTRUCT 11.0 m x 300 mm PIPE FOR DRIVES
CONSTRUCT (2) 300 mm STEEL END SECTIONS
300 mm INV. IN = 187.250
300 mm INV. OUT = 186.600
CONSTRUCT STONE FILL, CLASS C (2.0 x 3.0 x 0.3 m)
CONSTRUCT NON-WOVEN GEOTEXTILE
- 11** STA 15+00.0 - RT 4.00 TO STA 15+00.0 - LT 4.00
CONSTRUCT 8.4 m x 375 mm RCP
CONSTRUCT CB-S @ +00.0 - LT 4.00
375 mm INV. OUT = 186.884
375 mm INV. IN = 186.000
GRATE ELEV. = 186.040
- 12** STA 15+00.0 - RT 16.00 TO STA 15+00.0 - RT 4.00
CONSTRUCT 8.0 m x 375 mm RCP
INV. AT PIPE = 183.70
CONSTRUCT CB-S @ +00.0 - RT 4.00
375 mm INV. OUT = 184.554
375 mm INV. IN, WEST = 186.212
375 mm INV. IN, NORTH = 186.860
GRATE ELEV. = 187.000
CONSTRUCT 375 mm CONCRETE END SECTION
- 13** STA 15+00.0 - RT 16.00 TO STA 15+00.0 - RT 26.00
CONSTRUCT 3.0 x 12.2 m VEGETATED TREATMENT SWALE
(SEE PARKING LOT AND VEGETATED TREATMENT SWALE
DETAIL, SHEET)
FLOW LINE ELEV. IN = 183.700
FLOW LINE ELEV. OUT = 183.500 @ +30.0
CONSTRUCT STONE FILL, CLASS C (3.0 x 4.0 x 0.3 m)
(SEE MISCELLANEOUS DRAINAGE DETAILS, SHEET)
- 14** DELETED
- 15** STA 16+02.0 - RT 4.30 TO STA 17+07.0 - RT 7.10
REMOVE 83.2 m x 375 mm RCP (10.0 m SUBSIDIARY)
- 16** STA 16+23.0 - RT 5.00 TO STA 16+78.0 - RT 6.44
CONSTRUCT 86.3 m x 750 mm RCP
CONSTRUCT 1.0 m DIA. CB-S @ +79.0 - RT 6.44
750 mm INV. IN = 184.836
750 mm INV. OUT = 184.910
GRATE ELEV. = 187.0000
- 17** STA 16+52.0 - RT 4.30 TO STA 16+55.0 - LT 7.00
REMOVE CB @ +55.0 - LT 7.00
REMOVE 12.2 m x 375 mm RCP
- 18** STA 16+14.0 - RT 12.00 TO STA 16+52.0 - RT 4.20
REMOVE CB @ +52.0 - RT 4.20
REMOVE 37.6 m x 375 mm RCP (10.0 m SUBSIDIARY)
- 19** STA 16+20.3 - RT 49.00 TO STA 16+23.0 - RT 5.00
CONSTRUCT 1.0 m DIA. CB-S WITH SLAB TOP +23.0 - RT 5.00
750 mm INV. IN = 184.823
750 mm INV. OUT = 184.847
GRATE ELEV. = 187.400
CONSTRUCT 800 mm STEEL END SECTION @ +20.3 - RT 49.00
INV. @ PIPE = 184.373

- 20** STA 400+51.0 - RT 14.70 TO STA 400+67.4 - RT 14.70
CONSTRUCT STONE FILL, CLASS B (5.0 x 4.5 x 0.5 m)
CONSTRUCT 9.0 x 16.2 m VEGETATED TREATMENT SWALE
(SEE PARKING LOT AND VEGETATED TREATMENT SWALE, SHEET)
FLOW LINE ELEV. IN = 184.373
FLOW LINE ELEV. OUT = 183.787
- 21** STA 400+51.0 - RT 24.00 TO STA 400+67.4 - RT 24.00
CONSTRUCT STONE LINED SLOPE
(SEE PARKING LOT AND VEGETATED TREATMENT SWALE, SH.)

METRIC
DRAWING NAME OR APPROPRIATE CAD/S
SOFTWARE NAMING CONVENTION

STATE OF NEW HAMPSHIRE			
DEPARTMENT OF TRANSPORTATION - BUREAU OF HIGHWAY DESIGN			
DRAINAGE & UTILITY PLANS			
FEDERAL PROJECT NO.	STATE PROJECT NO.	SHEET NO.	TOTAL SHEETS
	P-4370		



R.F.S. FILE NAME	WINDOW NAME	FEDERAL PROJECT NO.	STATE PROJECT NO.	SHEET NO.	TOTAL SHEETS
ASSEMBLER	DRWGNO4		P-4370		

REVISIONS AFTER PROPOSAL	NUMBER	DATE	STATION	DESCRIPTION
NOTEBOOKS	BOOK	BOOK	BOOK	BOOK
DATE 8/87	DATE 10/87	DATE 11/87		
EXISTING DETAIL N. CONNOR	PROPOSED DESIGN J. CHAMBERLIN	SHEET CHECKED E. SULLIVAN	AS BUILT DETAILS	

SAMPLE PLANS
DATE 31-DEC-1998

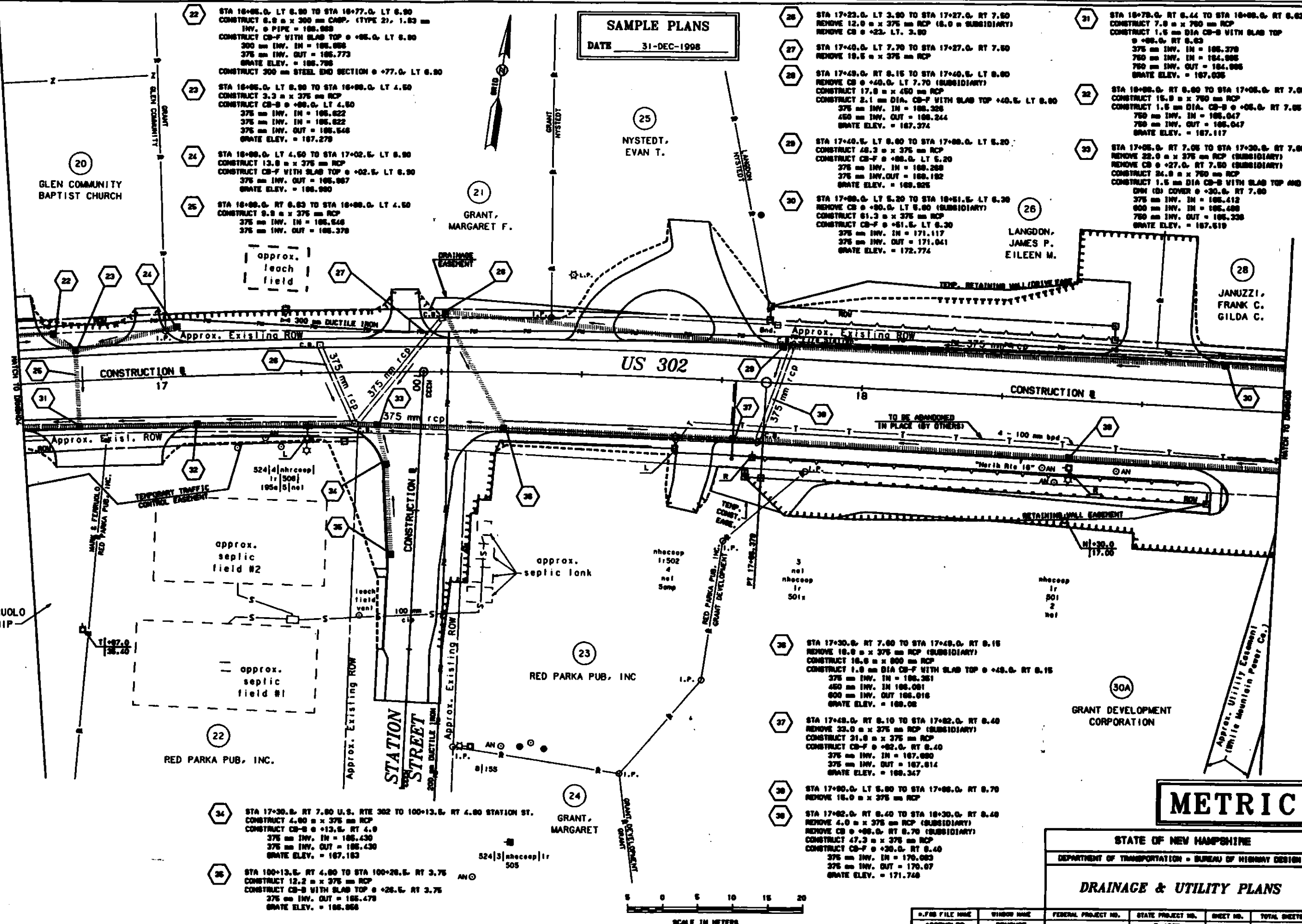

22 STA 16+85.0, LT 6.00 TO STA 16+77.0, LT 6.00
CONSTRUCT 6.0 x 300 mm CAMP, (TYPE 2), 1.03 mm
INV. @ PIPE = 186.989
CONSTRUCT CB-F WITH SLAB TOP @ +85.0, LT 6.00
300 mm INV. IN = 186.988
375 mm INV. OUT = 186.773
GRATE ELEV. = 186.788
CONSTRUCT 300 mm STEEL END SECTION @ +77.0, LT 6.00

23 STA 16+85.0, LT 6.00 TO STA 16+88.0, LT 4.50
CONSTRUCT 3.3 x 375 mm RCP
CONSTRUCT CB-S @ +88.0, LT 4.50
375 mm INV. IN = 186.822
375 mm INV. OUT = 186.822
GRATE ELEV. = 187.278

24 STA 16+88.0, LT 4.50 TO STA 17+02.5, LT 8.00
CONSTRUCT 13.0 x 375 mm RCP
CONSTRUCT CB-F WITH SLAB TOP @ +02.5, LT 8.00
375 mm INV. OUT = 186.987
GRATE ELEV. = 186.980

25 STA 16+88.0, RT 6.03 TO STA 16+88.0, LT 4.50
CONSTRUCT 9.8 x 375 mm RCP
375 mm INV. IN = 186.548
375 mm INV. OUT = 186.378

26 STA 17+23.0, LT 3.00 TO STA 17+27.0, RT 7.00
REMOVE 12.0 x 375 mm RCP (SUBSIDIARY)
REMOVE CB @ +23.0, LT. 3.00

27 STA 17+40.0, LT 7.70 TO STA 17+27.0, RT 7.00
REMOVE 19.5 x 375 mm RCP

28 STA 17+49.0, RT 8.15 TO STA 17+40.0, LT 8.00
REMOVE CB @ +40.0, LT 7.70 (SUBSIDIARY)
CONSTRUCT 17.8 x 450 mm RCP
CONSTRUCT 2.1 mm DIA. CB-F WITH SLAB TOP @ +40.0, LT 8.00
375 mm INV. IN = 188.328
450 mm INV. OUT = 188.244
GRATE ELEV. = 187.374

29 STA 17+40.0, LT 8.00 TO STA 17+88.0, LT 8.20
CONSTRUCT 48.3 x 375 mm RCP
CONSTRUCT CB-F @ +88.0, LT 8.20
375 mm INV. IN = 188.268
375 mm INV. OUT = 188.182
GRATE ELEV. = 188.925

30 STA 17+88.0, LT 8.20 TO STA 18+51.0, LT 6.38
REMOVE CB @ +88.0, LT 8.00 (SUBSIDIARY)
CONSTRUCT 61.3 x 375 mm RCP
CONSTRUCT CB-F @ +51.0, LT 6.38
375 mm INV. IN = 171.117
375 mm INV. OUT = 171.041
GRATE ELEV. = 172.774

31 STA 18+78.0, RT 6.44 TO STA 18+88.0, RT 6.03
CONSTRUCT 7.8 x 375 mm RCP
CONSTRUCT 1.5 mm DIA. CB-S WITH SLAB TOP
@ +88.0, RT 6.03
375 mm INV. IN = 186.378
750 mm INV. IN = 184.988
750 mm INV. OUT = 184.988
GRATE ELEV. = 187.038

32 STA 18+88.0, RT 6.00 TO STA 17+05.0, RT 7.00
CONSTRUCT 15.0 x 375 mm RCP
CONSTRUCT 1.5 mm DIA. CB-S @ +05.0, RT 7.00
750 mm INV. IN = 186.047
750 mm INV. OUT = 186.047
GRATE ELEV. = 187.117

33 STA 17+05.0, RT 7.00 TO STA 17+30.0, RT 7.00
REMOVE 22.0 x 375 mm RCP (SUBSIDIARY)
REMOVE CB @ +27.0, RT 7.00 (SUBSIDIARY)
CONSTRUCT 34.0 x 375 mm RCP
CONSTRUCT 1.5 mm DIA. CB-S WITH SLAB TOP AND
DNM (B) COVER @ +30.0, RT 7.00
375 mm INV. IN = 186.412
600 mm INV. IN = 186.488
750 mm INV. OUT = 186.338
GRATE ELEV. = 187.619

34 STA 17+30.0, RT 7.00 TO STA 17+49.0, RT 8.15
REMOVE 18.0 x 375 mm RCP (SUBSIDIARY)
CONSTRUCT 18.0 x 900 mm RCP
CONSTRUCT 1.8 mm DIA. CB-F WITH SLAB TOP @ +49.0, RT 8.15
375 mm INV. IN = 188.351
450 mm INV. IN = 188.081
600 mm INV. OUT = 188.016
GRATE ELEV. = 188.08

37 STA 17+48.0, RT 8.10 TO STA 17+82.0, RT 8.48
REMOVE 32.0 x 375 mm RCP (SUBSIDIARY)
CONSTRUCT 31.8 x 375 mm RCP
CONSTRUCT CB-F @ +82.0, RT 8.40
375 mm INV. IN = 187.880
375 mm INV. OUT = 187.814
GRATE ELEV. = 188.347

38 STA 17+80.0, LT 8.00 TO STA 17+88.0, RT 8.70
REMOVE 18.0 x 375 mm RCP

38 STA 17+82.0, RT 8.40 TO STA 18+30.0, RT 8.48
REMOVE 4.0 x 375 mm RCP (SUBSIDIARY)
REMOVE CB @ +88.0, RT 8.70 (SUBSIDIARY)
CONSTRUCT 47.3 x 375 mm RCP
CONSTRUCT CB-F @ +30.0, RT 8.40
375 mm INV. IN = 179.883
375 mm INV. OUT = 179.07
GRATE ELEV. = 171.748

34 STA 17+30.0, RT 7.00 U.S. RTE 302 TO 100+13.0, RT 4.00 STATION ST.
CONSTRUCT 4.00 x 375 mm RCP
CONSTRUCT CB-S @ +13.0, RT 4.0
375 mm INV. IN = 186.430
375 mm INV. OUT = 186.430
GRATE ELEV. = 187.183

36 STA 100+13.0, RT 4.00 TO STA 100+26.0, RT 3.75
CONSTRUCT 12.2 x 375 mm RCP
CONSTRUCT CB-S WITH SLAB TOP @ +26.0, RT 3.75
375 mm INV. OUT = 186.478
GRATE ELEV. = 186.968

METRIC

STATE OF NEW HAMPSHIRE
DEPARTMENT OF TRANSPORTATION - BUREAU OF HIGHWAY DESIGN

DRAINAGE & UTILITY PLANS

FILE NAME	WINDOW NAME	FEDERAL PROJECT NO.	STATE PROJECT NO.	SHEET NO.	TOTAL SHEETS
ASSEMBLER	DRAWER		P-4370		



SAMPLE PLANS

DATE 31-DEC-1998

REVISIONS AFTER PROPOSAL	NUMBER	DATE	STATION	DESCRIPTION
NOTEBOOKS	BOOK	PAGE		
	BOOK	PAGE		
	BOOK	PAGE		
EXISTING DETAIL N. CONCEPT	DATE	BY		
	PROPOSED DESIGN	J. CHAMBERLAIN	DATE	10/97
	SHEET CHECKED	E. BULLIVANT	DATE	11/97
	AS BUILT DETAILS		DATE	

- 40 STA 18+88.0- LT 7.00 TO STA 17+80.0- LT 6.00
REMOVE CB @ +88.0- LT 7.00
REMOVE 38.0 x 375 mm RCP 175.0 m (SUBSIDIARY)
- 41 STA 18+51.5- LT 8.30 TO STA 18+00.0- LT 8.30
CONSTRUCT 47.3 x 375 mm RCP
CONSTRUCT CB @ +00.0- LT. 8.30
300 mm INV. IN = 173.087
375 mm INV. IN = 173.183
375 mm INV. OUT = 173.011
GRATE ELEV. = 176.176
- 42 DELETED
- 43 STA 18+40.5- LT 4.35 TO STA 18+00.0- LT 7.00
REMOVE 52.0 x 375 mm RCP (3.0 m SUBSIDIARY)
- 44 STA 18+00.0- LT 8.30 TO STA 18+41.0- LT 7.00
REMOVE DI @ +37.0- LT 7.10 (SUBSIDIARY)
REMOVE 4.0 x 375 mm RCP @ +37.0- LT 7.10
TO +41.0- LT 7.00 (SUBSIDIARY)
CONSTRUCT 38.0 x 375 mm RCP
CONNECT TO EXISTING CB @ +41.0- LT 7.00 (SUBSIDIARY)
375 mm INV. OUT = 174.98

- 46 STA 18+40.5- LT 4.35 TO STA 18+41.0- LT 7.00
REMOVE 3.4 x 375 mm RCP
PLUS EXISTING CB OUTLET AS NEEDED @ +40.5- LT 7.00 (SUBSIDIARY)
REMOVE CH @ 18+40.5- LT 4.35 m (SUBSIDIARY)
- 48 STA 20+15.0- LT 7.30
REMOVE EXISTING CB
SALVAGE GRATE AND FRAME
CAP EXISTING UNDERDRAIN (SUBSIDIARY)
- 47 STA 18+30.0- RT 8.40 TO STA 18+70.0- RT 8.40
CONSTRUCT 38.0 x 375 mm RCP
CONSTRUCT 1.5 m DIA CB-F WITH SLAB TOP
@ +70.0- RT 8.40
300 mm INV. IN = 172.188
375 mm INV. IN = 172.080
375 mm INV. OUT = 172.04
GRATE ELEV. = 173.777

- 48 STA 18+70.0- RT 8.40 TO STA 18+88.0- RT 11.80
CONSTRUCT 2.5 x 300 mm RCP
CONSTRUCT CB-S WITH SLAB TOP @ +88.0- RT 11.8
300 mm INV. OUT = 172.823
GRATE ELEV. = 173.788
- 49 STA 18+70.0- RT 8.40 TO STA 18+20.0- RT 8.40
CONSTRUCT 48.8 x 375 mm RCP
CONSTRUCT CB-S @ +20.0- RT 8.40
375 mm INV. IN = 174.280
375 mm INV. OUT = 174.284
GRATE ELEV. = 176.017

- 50 STA 18+30.0- RT 8.40 TO STA 18+88.0- RT 8.80
CONSTRUCT 37.6 x 375 mm RCP
CONSTRUCT CB-S @ +88.0- RT 8.80
375 mm INV. IN = 176.282
375 mm INV. OUT = 176.208
GRATE ELEV. = 176.838
- 51 STA 18+88.0- RT 8.80 TO STA 18+88.0- RT 8.80
CONSTRUCT 25.0 x 375 mm RCP
CONSTRUCT CB-S @ +88.0- RT 8.80
375 mm INV. OUT = 176.516
GRATE ELEV. = 177.187

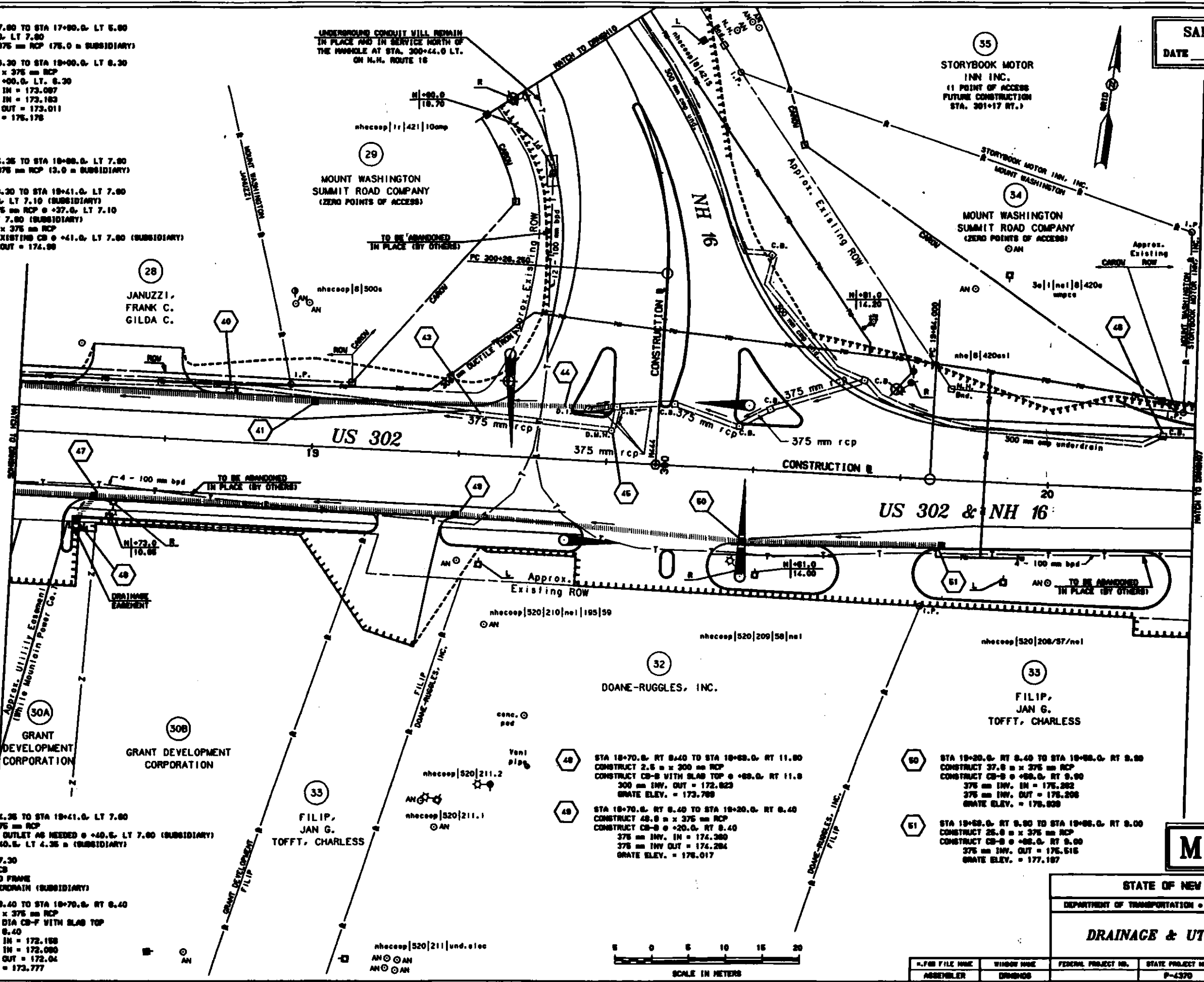

METRIC

STATE OF NEW HAMPSHIRE					
DEPARTMENT OF TRANSPORTATION • BUREAU OF HIGHWAY DESIGN					
DRAINAGE & UTILITY PLANS					
FILE NAME	WINDOW NAME	FEDERAL PROJECT NO.	STATE PROJECT NO.	SHEET NO.	TOTAL SHEETS
ASSEMBLER	DRWGNO		P-4370		

SAMPLE PLANS
DATE 31-DEC-1998

EXISTING DETAIL	DATE	4/98
PROPOSED DESIGN	DATE	9/98
SHEET CHECKED	DATE	10/98
AS BUILT DETAILS	DATE	

REVISIONS AFTER PROPOSAL	STATION	DESCRIPTION

NOTEBOOKS	PAGE
BOOK	PAGE
BOOK	PAGE
BOOK	PAGE

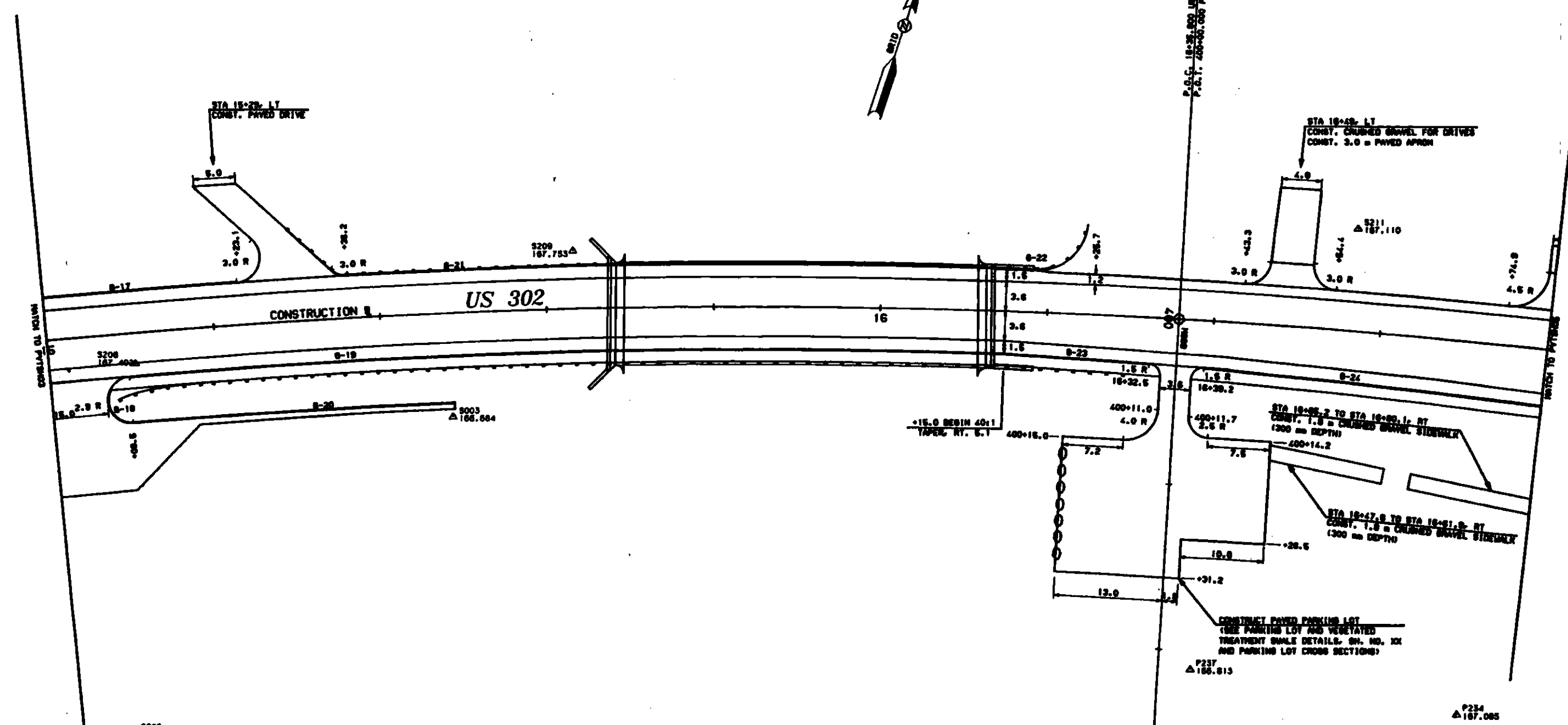

CURBING NOTES

1. END OF ALL NEW CURB SHALL TAPER FULL REVEAL TO FLUSH IN 2.4 METERS.



† DRAWING NAME OR APPROPRIATE CAD/D SOFTWARE NAMING CONVENTION

METRIC

STATE OF NEW HAMPSHIRE			
DEPARTMENT OF TRANSPORTATION - BUREAU OF HIGHWAY DESIGN			
CURBING AND PAVEMENT LAYOUT PLANS			
FILE NAME	WINDOW NAME	FEDERAL PROJECT NO.	STATE PROJECT NO.
ASSEMBLER	PVT/MS4		P-4370
		SHEET NO.	TOTAL SHEETS

SAMPLE PLANS
DATE 31-DEC-1998

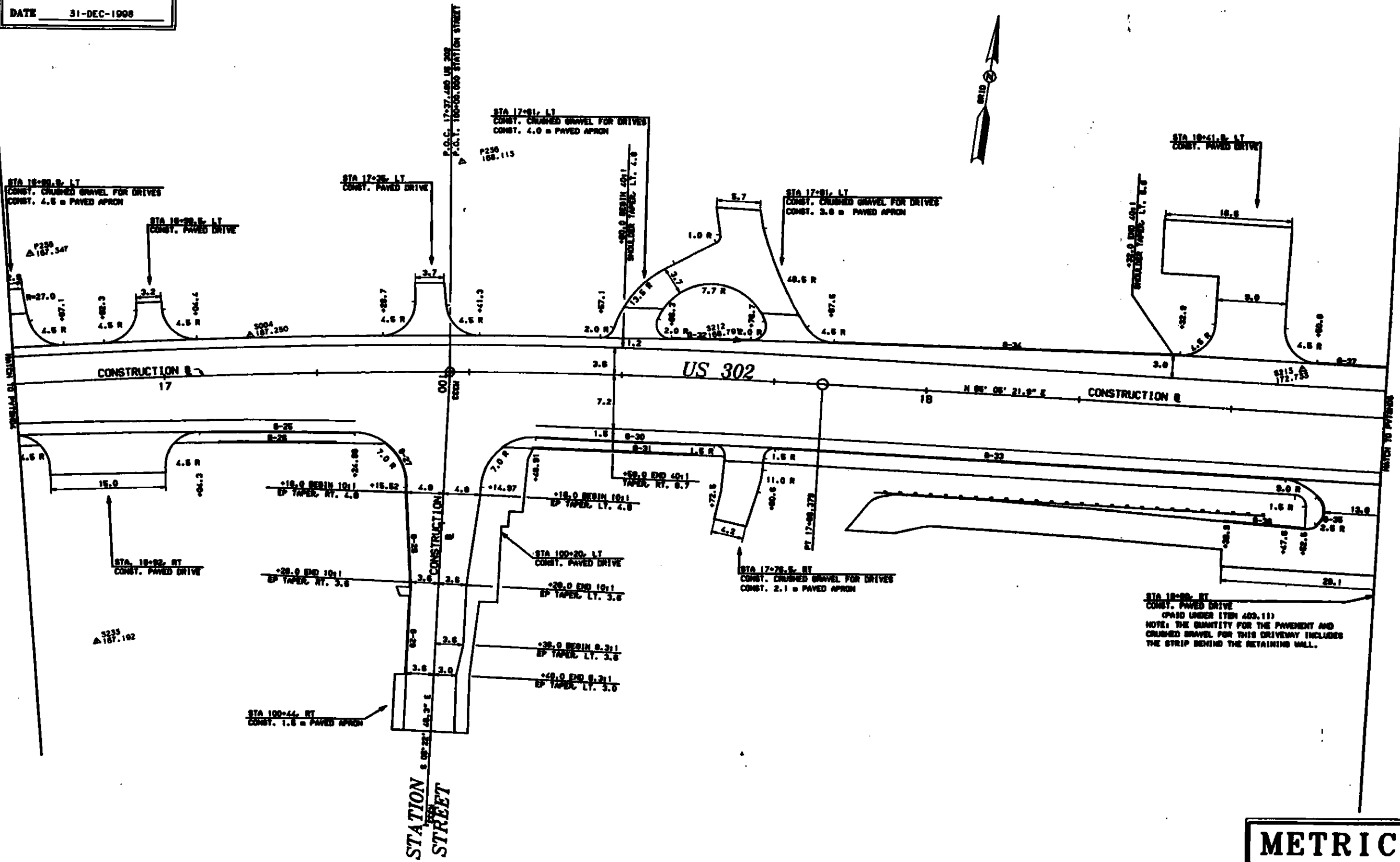

STA 18+92.8 RT
CONST. PAVED DRIVE
(PAID UNDER ITEM 403.11)
NOTE: THE QUANTITY FOR THE PAVEMENT AND CRUSHED GRAVEL FOR THIS DRIVEWAY INCLUDES THE STRIP BEHIND THE RETAINING WALL.

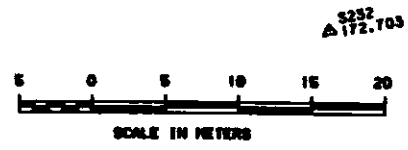

METRIC

STATE OF NEW HAMPSHIRE			
DEPARTMENT OF TRANSPORTATION • BUREAU OF HIGHWAY DESIGN			
CURBING AND PAVEMENT LAYOUT PLANS			
NO. FILE NAME	DESIGNER	FEDERAL PROJECT NO.	STATE PROJECT NO.
ASSEMBLER	PVT/ONS		P-4370
DATE	DATE	SHEET NO.	TOTAL SHEETS

EXISTING DETAIL	DATE	BY
PROPOSED DESIGN	DATE	BY
SHEET CHECKED	DATE	BY
AS BUILT DETAILS	DATE	BY

REVISIONS AFTER PROPOSAL	STATION	DESCRIPTION

NOTEBOOKS	PAGE
BOOK	
BOOK	
BOOK	

EXISTING DETAIL	DATE	BY	REVISIONS AFTER PROPOSAL
PROPOSED DESIGN	DATE	BY	STATION
SHEET CHECKED	DATE	BY	DESCRIPTION
AS BUILT DETAILS	DATE	BY	

NUMBER	DATE	STATION	DESCRIPTION

NOTES	BOOK	PAGE

CURVE NO. 1 - NH 16
 PI=300+44.410
 N =179094.181
 E =339007.618
 $\Delta =37^{\circ}-35'-48.4''$ LT.
 T =18.157 m
 R =53.340 m
 L =35.001 m
 E =3.006 m

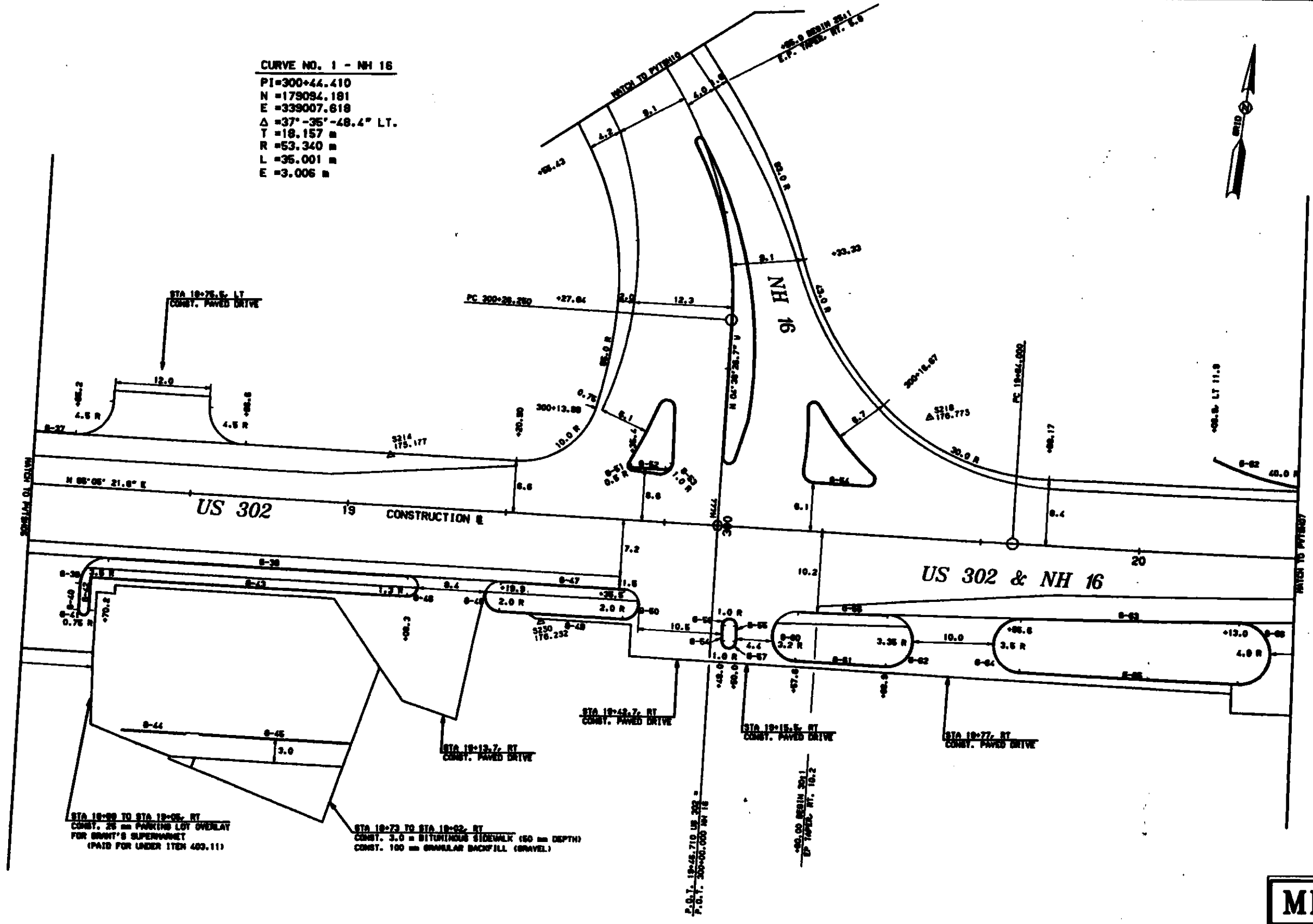

SAMPLE PLANS
 DATE 31-DEC-1998

METRIC

STATE OF NEW HAMPSHIRE			
DEPARTMENT OF TRANSPORTATION • BUREAU OF HIGHWAY DESIGN			
CURBING AND PAVEMENT LAYOUT PLANS			
F.FSD FILE NAME	WINDOW NAME	FEDERAL PROJECT NO.	STATE PROJECT NO.
ASSEMBLER	PVT/MSD		P-4370
		SHEET NO.	TOTAL SHEETS

SAMPLE PLANS
DATE 31-DEC-1998

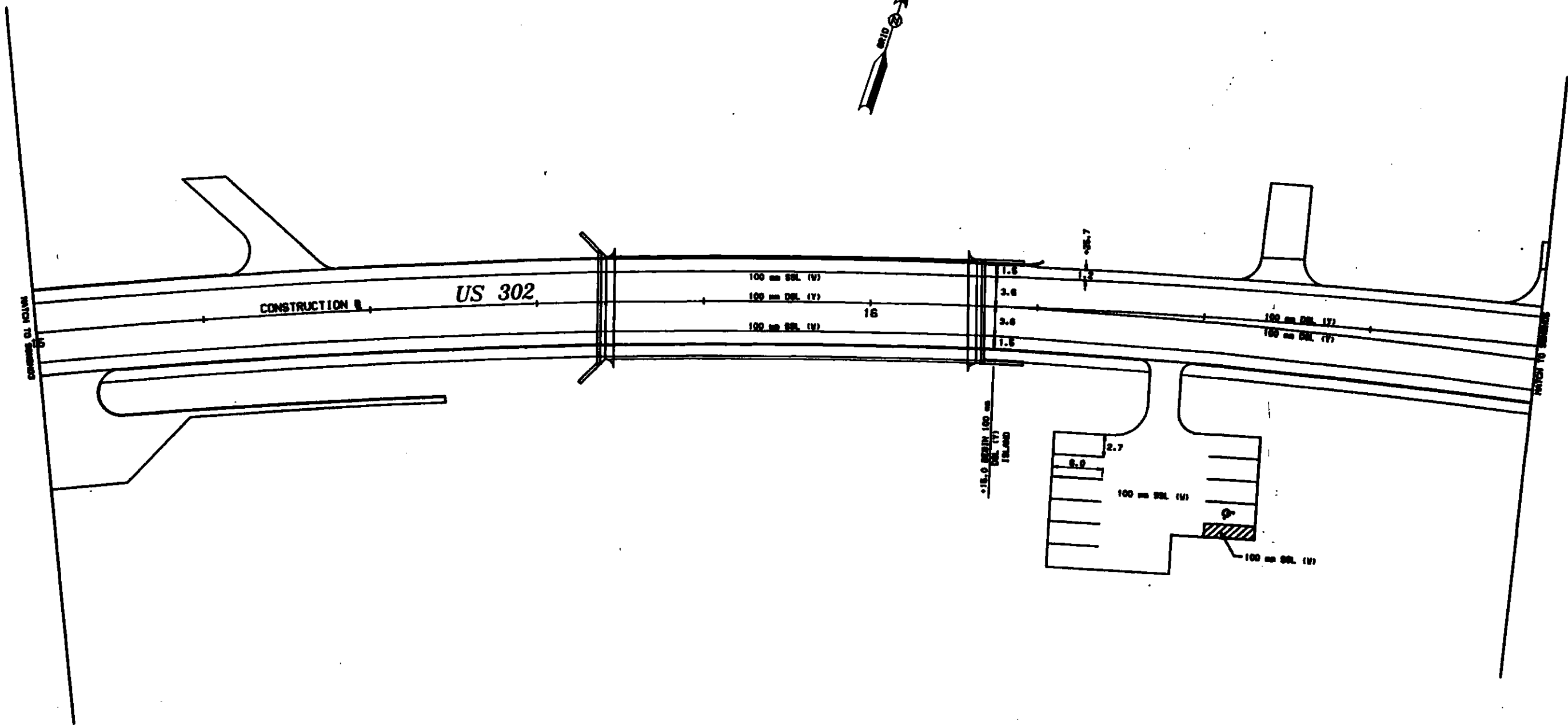

PAVEMENT MARKING NOTE

1. ALL FINAL PAVEMENT MARKINGS SHALL BE RETRO-REFLECTIVE THERMOPLASTIC PAVEMENT MARKINGS EXCEPT FOR MARKINGS ON GRANT'S DEVELOPMENT. ALL STRIPING AND SYMBOLS AT GRANT'S ENTRANCE AND SUPERMARKET PARKING LOT SHALL BE RETROREFLECTIVE PAINT PAVEMENT MARKINGS.



† DRAWING NAME OR APPROPRIATE CAD/D SOFTWARE NAMING CONVENTION

METRIC

STATE OF NEW HAMPSHIRE			
DEPARTMENT OF TRANSPORTATION • BUREAU OF HIGHWAY DESIGN			
PAVEMENT MARKING & SIGNING PLANS			
GENERAL PROJECT NO.	STATE PROJECT NO.	SHEET NO.	TOTAL SHEETS
	P-4370	XXI	

EXISTING DETAIL	DATE	BY
PROPOSED DESIGN	DATE	BY
SHEET CHECKED	DATE	BY
AS BUILT DETAILS	DATE	BY

REVISIONS AFTER PROPOSAL	STATION	DESCRIPTION

NUMBER	DATE	STATION

NOTEBOOKS	BOOK	PAGE

SAMPLE PLANS
DATE 31-DEC-1998

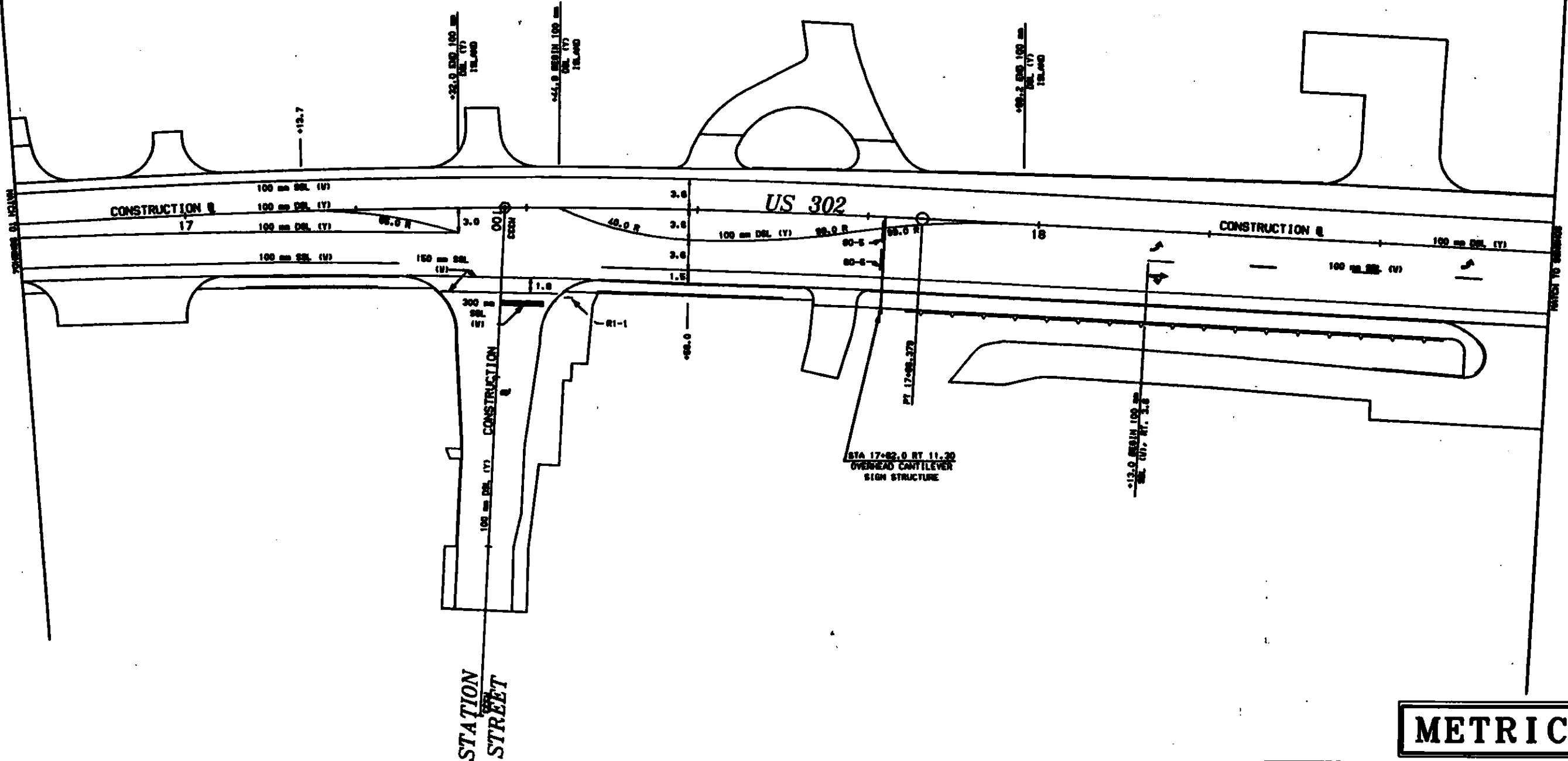

METRIC

STATE OF NEW HAMPSHIRE
DEPARTMENT OF TRANSPORTATION • BUREAU OF HIGHWAY DESIGN
**PAVEMENT MARKING
& SIGNING PLANS**

EXISTING DETAIL	DATE	BY	PREP
PROPOSED DESIGN	DATE	BY	DESIGN
SHEET CHECKED	DATE	BY	CHECK
AS BUILT DETAILS	DATE	BY	AS BUILT

NOTEBOOKS	DATE	STATION	DESCRIPTION
BOOK			
BOOK			
BOOK			

REVISIONS AFTER PROPOSAL	DATE	STATION	DESCRIPTION

H.P.D. FILE NAME	WINDOW NAME	FEDERAL PROJECT NO.	STATE PROJECT NO.	SHEET NO.	TOTAL SHEETS
ASSEMBLER	DESIGNER		P-4370	XX	

STOP LINES	
NORTH	- STA. 300+08.6
EAST	- STA. 19+60.0
SOUTH	- STA. 19+49.9 TO 19+54.4
WEST	- STA. 19+34.8
GRANTS	- STA. 18+60.0 TO 18+66.7

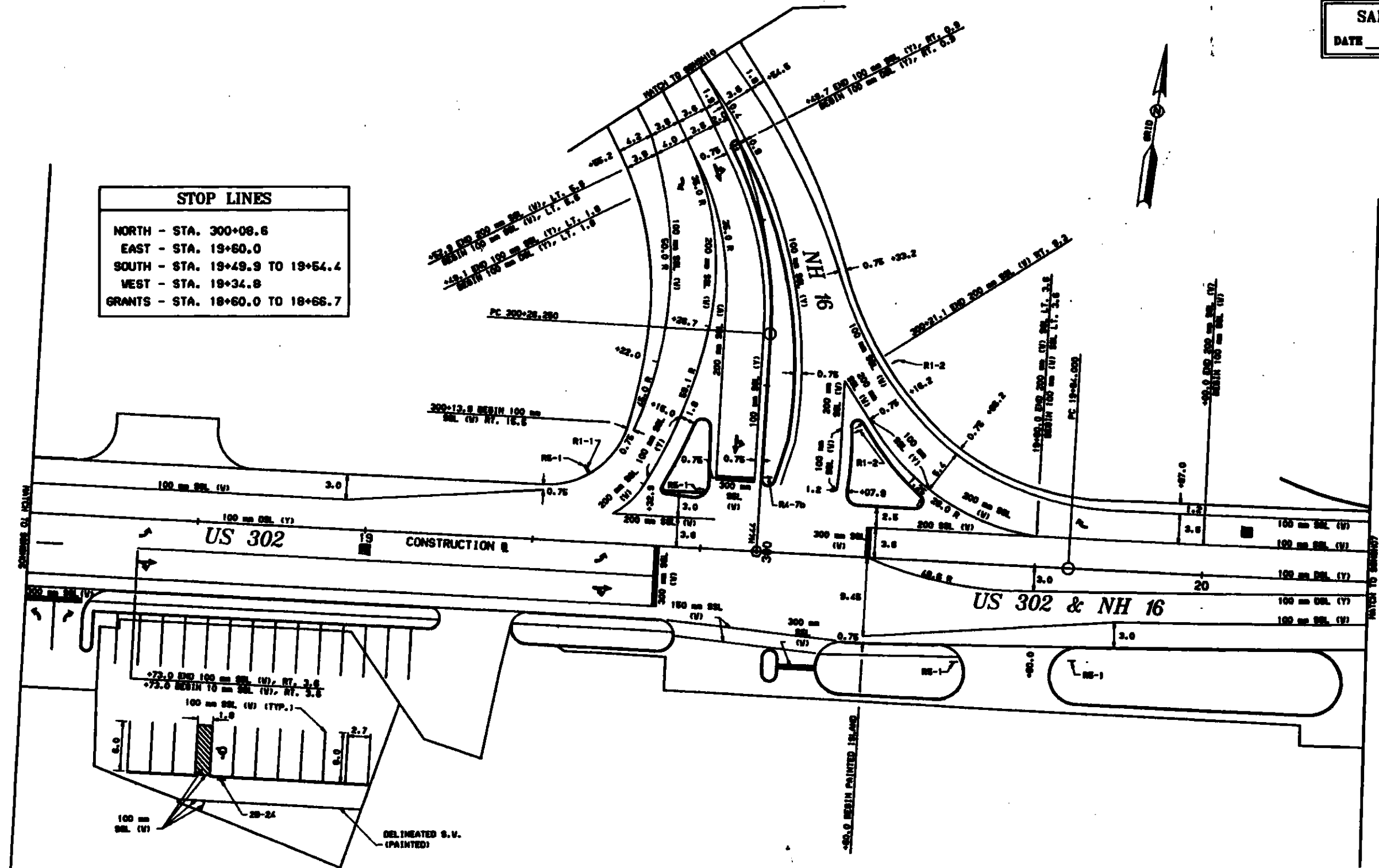

METRIC

STATE OF NEW HAMPSHIRE			
DEPARTMENT OF TRANSPORTATION • BUREAU OF HIGHWAY DESIGN			
PAVEMENT MARKING & SIGNING PLANS			
#/700 FILE NAME	WINDY NAME	FEDERAL PROJECT NO.	STATE PROJECT NO.
APPROVALER	DESIGNER		P-4370
		SHEET NO.	TOTAL SHEETS

EXISTING DETAIL		REVISED / PLAN PREP		DATE		4/96	
PROPOSED DESIGN	R. ZABALA	DATE	8/95	DATE	8/95	DATE	8/95
SHEET CHECKED	A. J. BURNS	DATE	10/95	DATE	10/95	DATE	10/95
AS BUILT DETAILS		DATE		DATE		DATE	

REVISIONS AFTER PROPOSAL		DESCRIPTION	
NUMBER	STATION	DATE	STATION

NOTEBOOKS		PAGE	
BOOK	BOOK	PAGE	PAGE

STANDARD 80 NEMA CONTROLLER

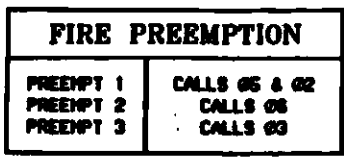
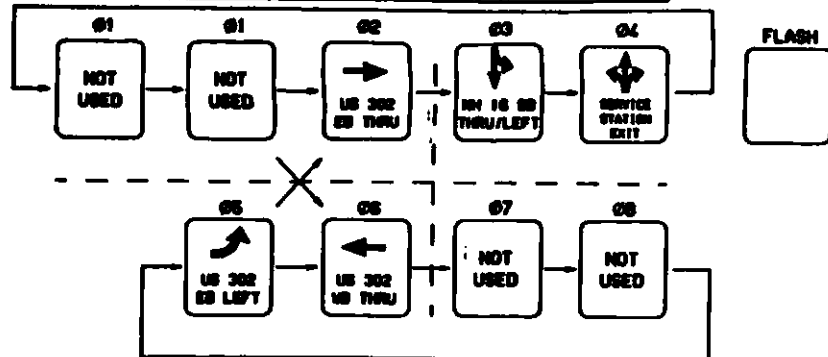

SIGNAL PHASING

TIMING IN SECONDS	01	01	02	03	04	05	06	07	08
INITIAL INTERVAL			8	5	5	5	8		
VEHICLE EXTENSION			4	3	3	3	4		
MAXIMUM I			25	25	10	20	25		
MAXIMUM II			25	25	10	20	25		
YELLOW			4	4	4	4	4		
ALL RED			2	2	2	2	2		
WALK/DONT WALK									
RECALL			SOFT	OFF	OFF	OFF	SOFT		
DETECTOR									

SIGNAL HEADS

ALL LENSES 300 mm WITH 125 mm LOUVERED BACK PLATE

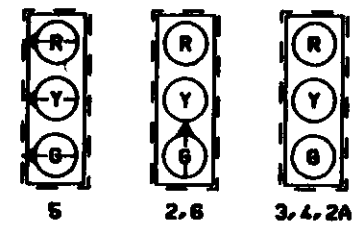

GENERAL NOTES

- EXISTING CONCRETE FULL BOXES LABELED \diamond SHALL BE REMOVED (SUBSIDIARY) AND SALVAGED TO THE BUREAU OF TRAFFIC. SEE THE PROSECUTION OF WORK FOR CONTACT NAMES.
- PAVEMENT SAVING FOR LOOP DETECTORS, CONDUIT (WHEN REQUIRED), AND JACKING PITS (WHEN REQUIRED) SHALL BE SUBSIDIARY TO 616. ITEMS. REPLACEMENT OF PAVEMENT FOR CONDUIT TRENCHES AND JACKING PITS WILL BE PAID UNDER ITEM 403.12 OR 403.96.
- HAST ARMS SHALL BE ORIENTED PERPENDICULAR TO ROADWAY ALIGNMENTS UNLESS OTHERWISE NOTED.
- PERMANENT LIGHTING SHALL CONSIST OF THREE (3) 250 WATT H.P.S., SEMI CUT-OFF, TYPE 3 OR APPROVED EQUAL MOUNTED ON A 3.6 m BRACKET ARM AS NOTED BELOW:
 - STA 19+26.0 LT 14.00 m WITH A 10.7 MOUNTING HEIGHT
 - STA 19+81.0 LT 14.20 m WITH A 12.2 MOUNTING HEIGHT
 - STA 300+80.0 LT 18.70 m WITH A 10.7 MOUNTING HEIGHT

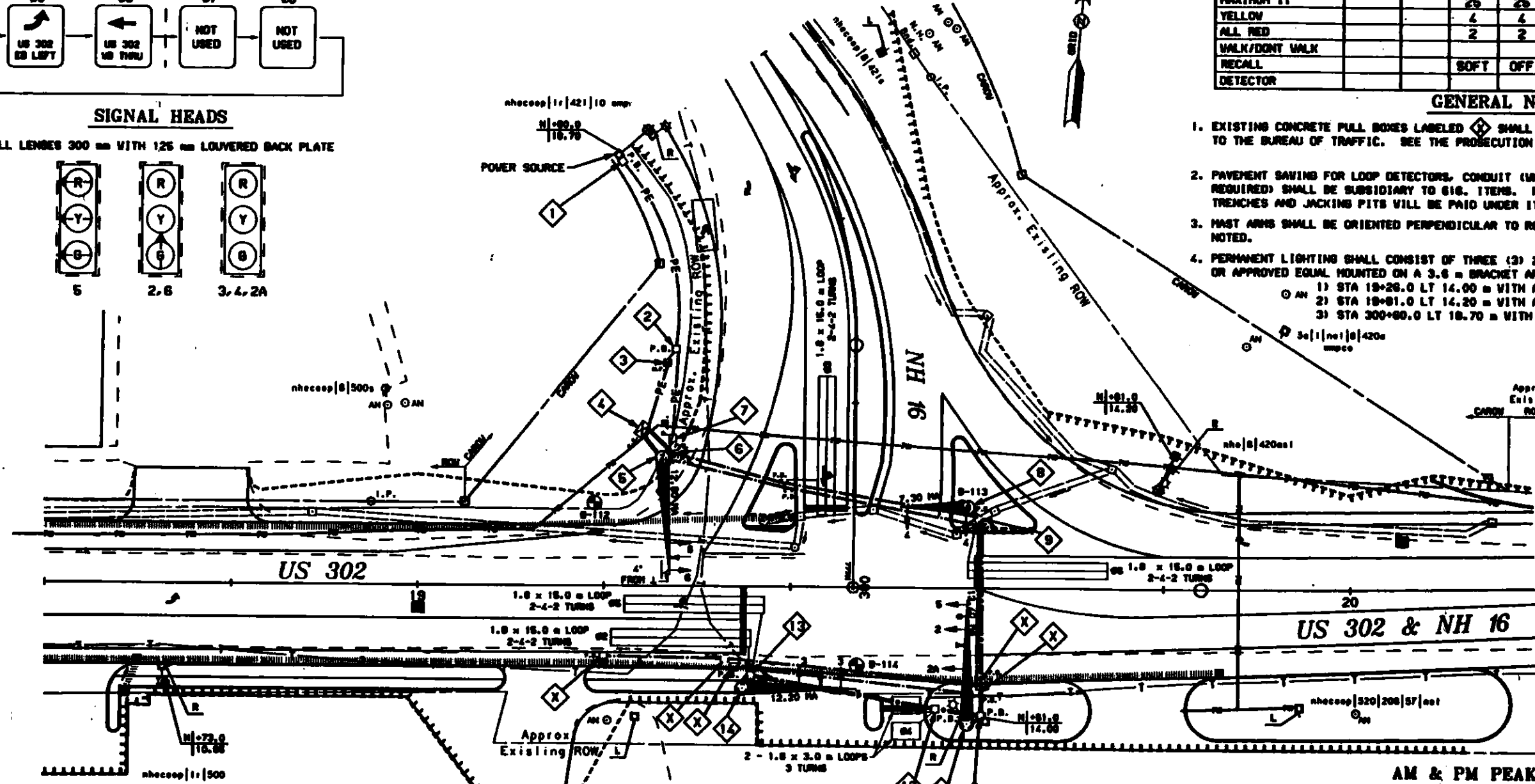

TEST BORINGS

HOLE NO.	LOCATION
B-112	19+19.0 LT 8.00
B-113	19+88.4 LT 8.00
B-114	19+47.0 RT 8.40

DETECTOR SCHEDULE

STREET	DIRECTION	LANE	AMPLIFIER			INDUCT. U H	RESIST. OF LOOP	RESIST. LOOP TO GROUND (MED CHNS)	RESIST. SHIELD TO GROUND (MED CHNS)
			0	NO.	CHANNEL				
US 302	EAST	THRU	2	1	2				
NH 16	SOUTH	THRU/LEFT	3	2	3				
SERVICE STATION	NORTH	THRU	4	3	4				
US 302	NORTH	LEFT	5	4	5				
US 302	WEST	THRU	6	5	6				

RECORD FIELD MEASUREMENTS ABOVE

SAMPLE PLANS
DATE 31-DEC-1998

AM & PM PEAK TRAFFIC VOLUMES

YEAR	AM PEAK		PM PEAK	
	US 302	NH 16	US 302	NH 16
1998	1540	400	1140	170
2016	1700	500	1200	200

METRIC

STATE OF NEW HAMPSHIRE
DEPARTMENT OF TRANSPORTATION • BUREAU OF HIGHWAY DESIGN

SIGNALIZATION PLAN

WINDOW NAME: / FOR FOLDER: FEDERAL PROJECT NO.: STATE PROJECT NO.: SHEET NO.: TOTAL SHEETS: P-4378

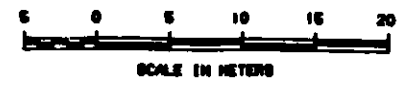

EXISTING DETAIL		DATE 2/23/58	
BY: P. R. DEK	DATE 2/23/58	DATE 2/23/58	
PROPOSED DESIGN	BY: A. LEACH	DATE 10/9/58	
SHEET CHECKED	BY: H. HOBBS	DATE 10/9/58	
AS BUILT DETAILS	BY: S. COOPER	DATE	

REVISIONS AFTER PROPOSAL	
NUMBER	DATE
STATION	DESCRIPTION

NOTEBOOKS	
BOOK	PAGE
BOOK	PAGE
BOOK	PAGE

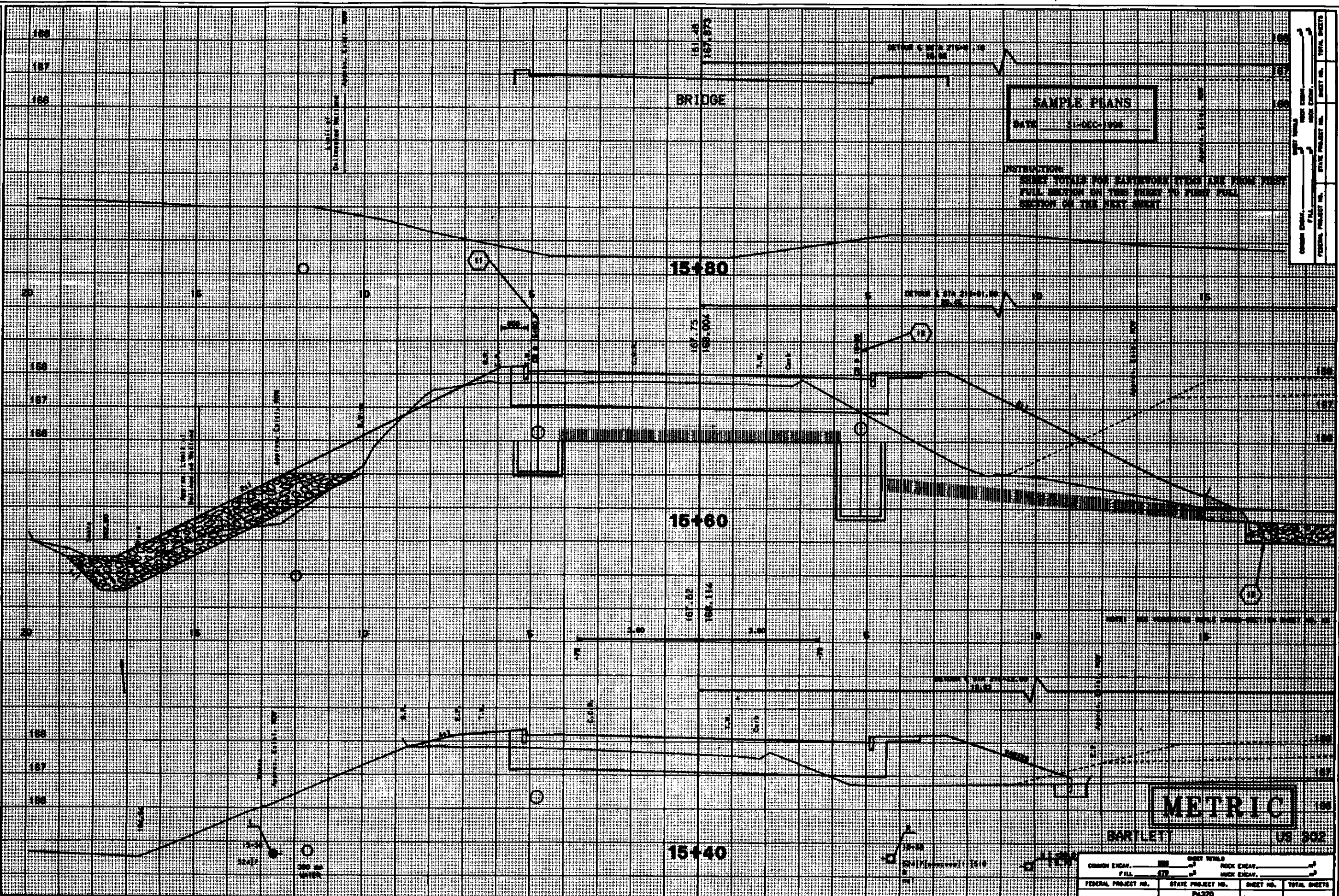

METRIC

COMMON ENCAV.		BEST WINDS	
FILL	720	ROCK ENCAV.	0
FEDERAL PROJECT NO.	STATE PROJECT NO.	SHEET NO.	TOTAL SHEETS
	PL370		

EXISTING DETAIL		DATE		REVISIONS AFTER PROPOSAL	
PROPOSED DESIGN	A. LEACH	DATE 2/27/80	STATION	NUMBER	DATE
SHEET CHECKED	M. HERRISON	DATE 10/19/80	STATION	BOOK	PAGE
AS BUILT DETAILS	A.E. REYNOLDS	DATE 2/27/80	STATION	BOOK	PAGE

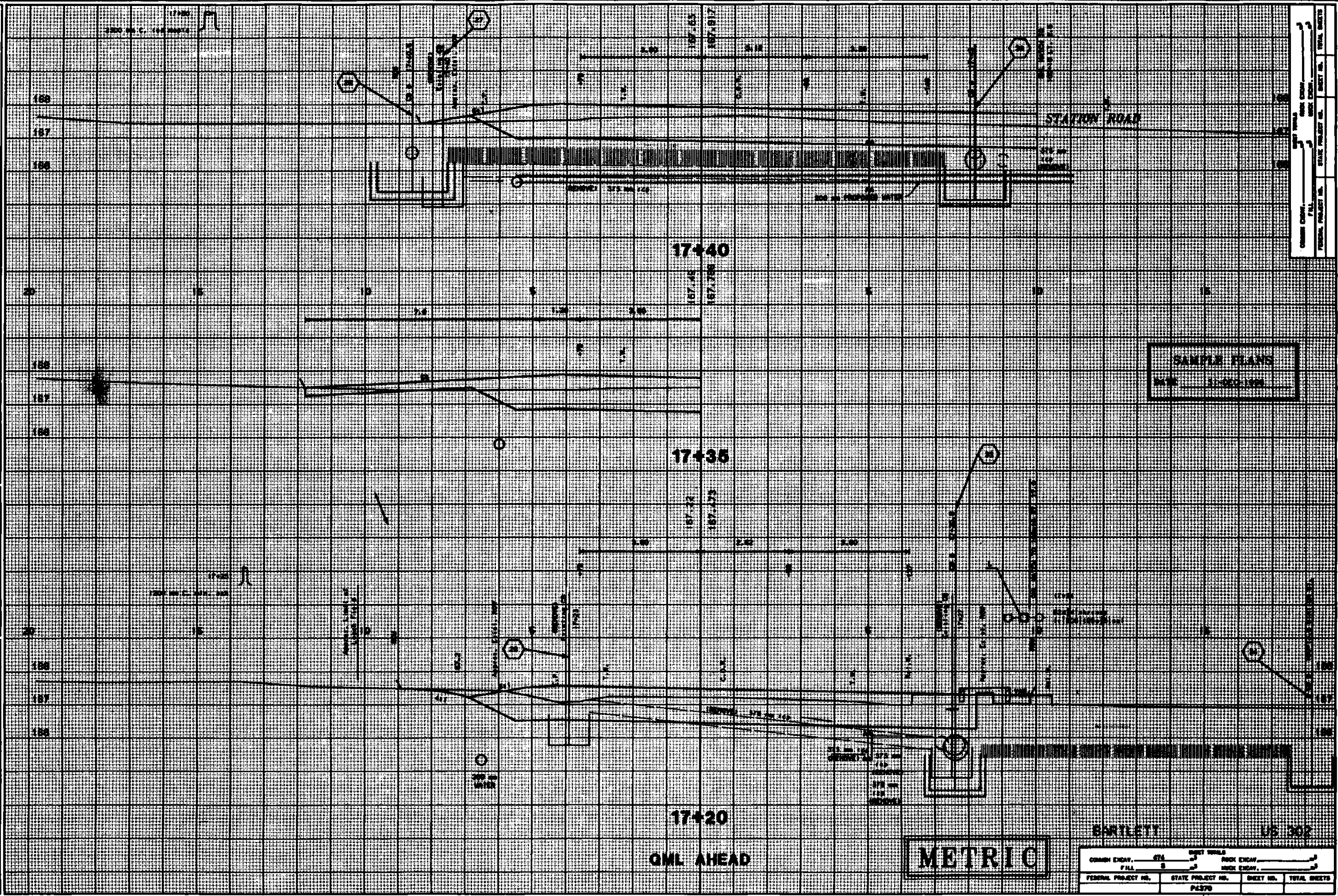

COMMON ENGV. 474		SHEET TOTALS	
FILL 8	ROCK ENGV. 1		
FEDERAL PROJECT NO. P4370	STATE PROJECT NO.	SHEET NO.	TOTAL SHEETS

EXISTING DETAIL B. PEX	DATE	REVISIONS AFTER PROPOSAL	STATION
PROPOSED DESIGN A. LACH	DATE 2/27/88	NUMBER	DATE
SHEET CHECKED T. MORTIMER	DATE 10/9/88	STATION	DATE
AS BUILT DETAILS	DATE	STATION	DATE

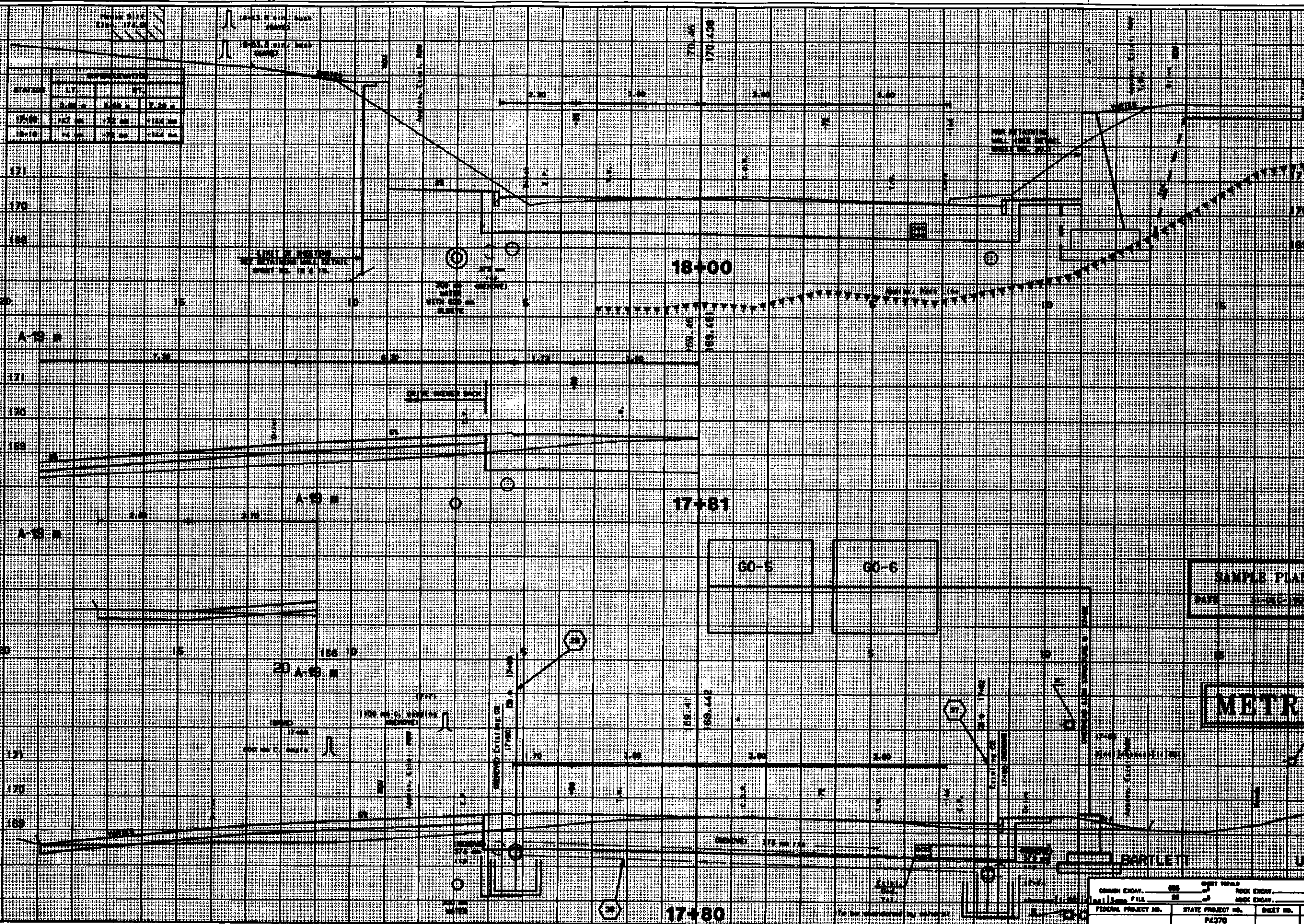

STATION	LT	RT
17+00	1.20 m	1.20 m
17+10	1.20 m	1.20 m

SAMPLE PLANS
DATE 1-DEC-1988

METRIC

FEDERAL PROJECT NO.	STATE PROJECT NO.	SHEET NO.	TOTAL SHEETS
	P4370		

COMMON EXCAV.	ROCK EXCAV.
FILL	BACK EXCAV.
FEDERAL PROJECT NO.	STATE PROJECT NO.
SHEET NO.	TOTAL SHEETS

EXISTING DETAIL		DATE		DATE		DATE		DATE		DATE	
PROPOSED DESIGN		DATE		DATE		DATE		DATE		DATE	
SHEET CHECKED		DATE		DATE		DATE		DATE		DATE	
AS BUILT DETAILS		DATE		DATE		DATE		DATE		DATE	
REVISIONS AFTER PROPOSAL		STATION		STATION		STATION		STATION		STATION	
NUMBER		DATE		DATE		DATE		DATE		DATE	
DESCRIPTION		DESCRIPTION		DESCRIPTION		DESCRIPTION		DESCRIPTION		DESCRIPTION	

NOTEBOOKS		PAGE		PAGE		PAGE	
BOOK	BOOK	PAGE	PAGE	PAGE	PAGE	PAGE	PAGE

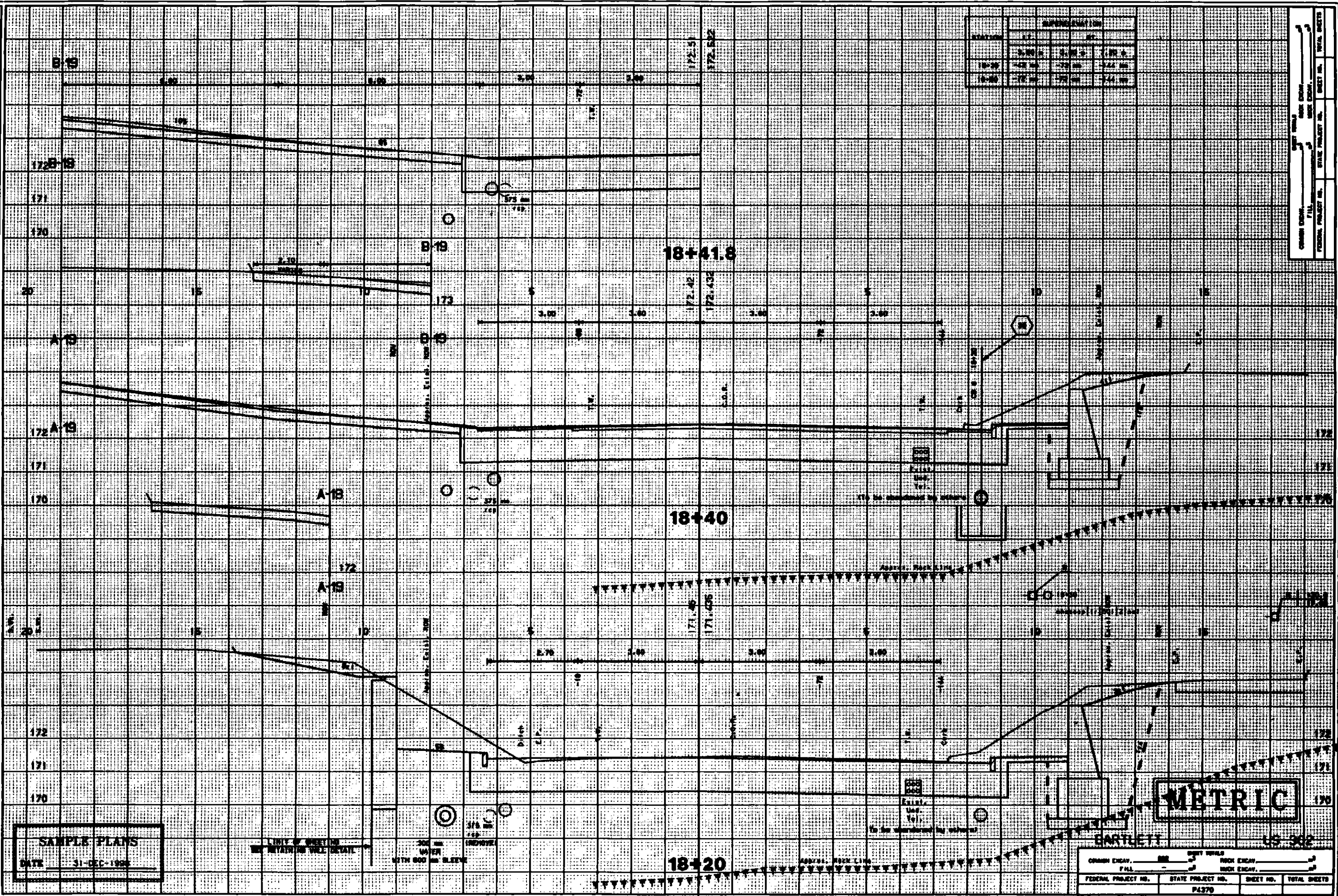

COMMON ENCAV.		ROCK ENCAV.	
18+20	18+40	18+20	18+40
170.00	170.00	170.00	170.00
171.00	171.00	171.00	171.00
172.00	172.00	172.00	172.00

SAMPLE PLANS
DATE 31-DEC-1998

METRIC

COMMON ENCAV.		ROCK ENCAV.	
FULL	ROCK ENCAV.	FULL	ROCK ENCAV.
FEDERAL PROJECT NO.	STATE PROJECT NO.	SHEET NO.	TOTAL SHEETS
	P4370		

EXISTING DETAIL		DATE		REVISIONS AFTER PROPOSAL	
A. RICH	DATE	2/21/78	STATION	DESCRIPTION	
A. LORON	DATE	10/17/78	STATION		
SHEET CHECKED	DATE	2/23/78	STATION		
A.S. MERRIN	DATE		STATION		
AS BUILT DETAILS		DATE			
	DATE				

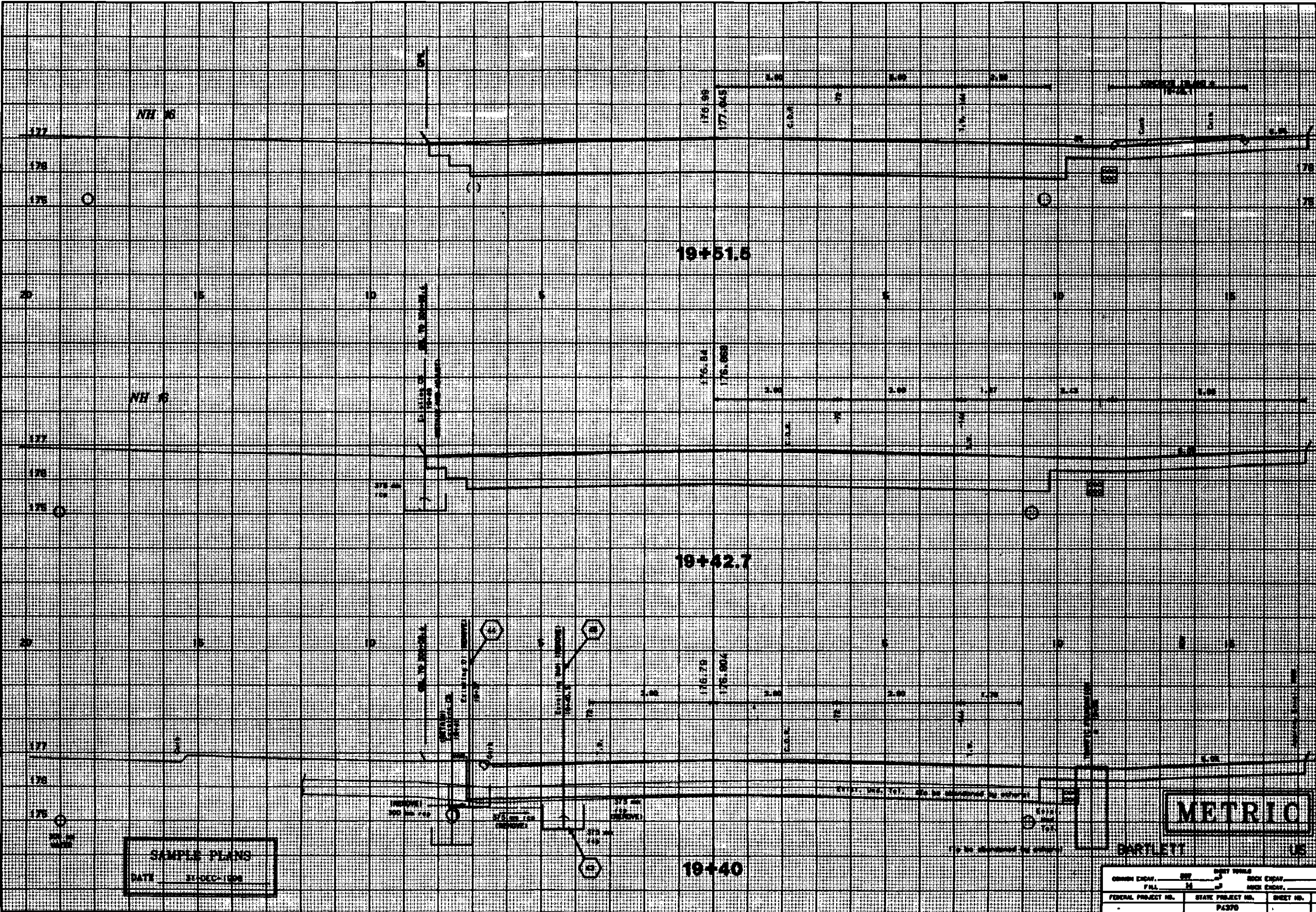

SAMPLE PLANS
DATE: 2/20/78

METRIC

BARTLETT US 302

CONTRACT NO.	STATE PROJECT NO.	SHEET NO.	TOTAL SHEETS
	P4370		

CONTRACT NO.	STATE PROJECT NO.	SHEET NO.	TOTAL SHEETS

EXISTING DETAIL		DATE		B. PERK	
PROPOSED DESIGN	DATE	2/2/78	A. LEACH		DATE
SHEET CHECKED	DATE	10/17/78	K. MONTGOMERY		DATE
AS BUILT DETAILS		DATE		R.L. NEWMAN	
				2/27/78	
NOTEBOOKS			REVISIONS AFTER PROPOSAL		
BOOK	PAGE	STATION	DATE	STATION	DESCRIPTION
BOOK	PAGE				
BOOK	PAGE				

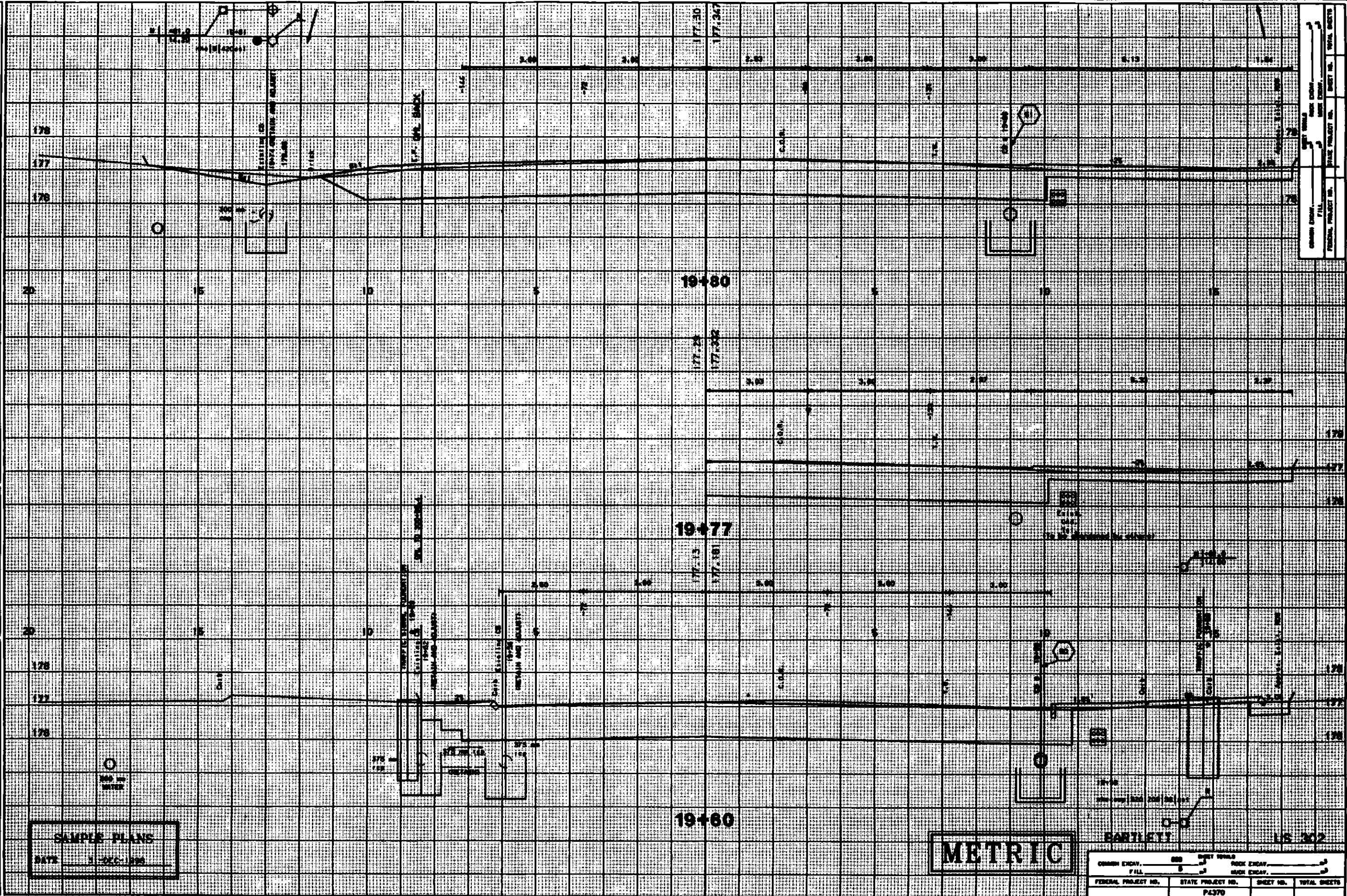

SAMPLE PLANS
DATE 1-20-1980

METRIC

COMMON EXCAV.	800	SHRIMP WORLD	ROCK EXCAV.	800
FILL	500		PAVED EXCAV.	800
FEDERAL PROJECT NO.	STATE PROJECT NO.	SHEET NO.	TOTAL SHEETS	
	P4370			

REVISIONS AFTER PROPOSAL

NUMBER	DATE	STATION	DESCRIPTION

NOTEBOOKS	PAGE	PAGE	PAGE
BOOK			
BOOK			
BOOK			

EXISTING DETAIL	DATE	DATE	DATE
JALIE SMITH	7/1/78	7/15/78	7/30/78
PROPOSED DESIGN	BRIAN JONES		
SHEET CHECKED	PETER DOC		
AS BUILT DETAILS			

- 1 STA 201+07.0- B STREET, RT 17.50 m TO STA 101+37.5- A STREET, RT 13.00 m
CONSTRUCT 40.0 m TREATMENT SHALE, TYPE A
FLOW LINE ELEV. IN = 99.000
FLOW LINE OUT = 97.900
SEE TREATMENT SHALE DETAIL, SHEET NO. XX
- 2 STA 201+37.5- RT 13.00 m TO STA 101+38.5- RT 9.00 m
CONSTRUCT 43.0 m x 800 mm RCP
CONSTRUCT P.C. @ HWY HEADER @ +37.5- RT 13.00 m
INV. @ HWY = 99.000
CONSTRUCT CLASS B- STONE FILL (3.0 x 4.0 x 0.6 m)
SEE STONE DITCH DETAIL, SHEET NO. XX
CONSTRUCT CD-S @ +38.5- RT 13.00 m
600 mm INV. OUT = 100.000
100 mm INV. IN = 101.500
450 mm INV. IN = 100.500
GRATE ELEV. = 100.500
- 3 STA 201+03.5- B STREET, RT 12.20 m TO STA 101+31.0- A STREET, RT 9.50 m
REMOVE EXISTING HEADER
REMOVE 8.0 m x 450 mm RCP
REMOVE EXISTING O.I.
- 4 STA 101+38.5- RT 9.00 m TO STA 103+00.0- RT 1.5 m
CONSTRUCT 180.0 m x 150 mm PIPE UNDERDRAIN
REMOVE 200.0 m x 150 mm PCDP (SUBSIDIARY)
- 5 STA 101+38.5- RT 9.00 m TO STA 101+35.0- CL
CONSTRUCT 7.0 m x 450 mm RCP
CONSTRUCT CD-S @ +35.0- CL
450 mm INV. OUT = 102.000
450 mm INV. IN = 102.250
GRATE ELEV. = 102.750
- 6 STA 101+35.0- CL TO STA 101+33.5- LT 9.00 m
CONSTRUCT 7.0 m x 450 mm RCP
CONSTRUCT 2.1 m DIA CD-S W/ SLAB TOP @ +33.5- LT 9.00 m
450 mm INV. OUT = 103.500
450 mm INV. IN = 103.750
375 mm INV. IN = 104.000
150 mm INV. IN = 104.500
GRATE ELEV. = 110.000
- 7 STA 101+33.5- LT 9.00 m TO STA 103+00.0- LT 7.50 m
CONSTRUCT 170.0 m x 150 mm PIPE UNDERDRAIN
- 8 STA 101+33.5- A STREET, LT 9.00 m TO STA 201+38.0- B STREET, RT 9.50 m
CONSTRUCT 8.0 m x 375 mm RCP, CLASS IV
CONSTRUCT P.C. @ HWY HEADER @ +38.0- RT 9.50 m
INV. @ HWY = 104.500
CONSTRUCT CLASS C- STONE FILL (3.0 x 4.0 x 0.6 m)
SEE STONE DITCH DETAIL, SHEET NO. XX
- 9 STA 201+38.0- RT 9.50 m TO STA 203+00.0- RT 9.50 m
CONSTRUCT 180.0 m x 2.4 m GRASS LINED DITCH
SEE GRASS LINED DITCH DETAIL, SHEET NO. XX
- 10 STA 101+33.5- A STREET, LT 9.00 m TO STA 201+36.0- B STREET, RT 9.00 m
CONSTRUCT 8.5 m x 450 mm RCP
CONSTRUCT CD-S @ +36.0- RT 9.00 m
450 mm INV. OUT = 104.000
375 mm INV. IN WEST = 104.250
375 mm INV. IN NORTH = 104.250
GRATE ELEV. = 110.250
REMOVE EXISTING OI @ +36.0- RT 9.00 m (SUBSIDIARY)
- 11 STA 101+31.0- A STREET, RT 9.50 m TO STA 201+35.0- B STREET, LT 9.00 m
REMOVE 24.0 m x 375 mm RCP
- 12 STA 201+35.0- RT 9.00 m TO LT 9.00 m
CONSTRUCT 14.0 m x 375 mm RCP
CONSTRUCT CD-S @ +35.0- LT 9.00 m
375 mm INV. OUT = 104.750
GRATE ELEV. = 110.250
- 13 STA 201+35.0- LT 9.00 m TO STA 201+40.0- LT 9.00 m
REMOVE 18.0 m x 300 mm RCP
REMOVE EXISTING OI
- 14 STA 201+35.0- RT 9.00 m TO STA 202+00.0- RT 9.00 m
CONSTRUCT 23.0 m x 375 mm RCP
CONSTRUCT CD-S @ +00.0- RT 9.00 m
375 mm INV. OUT = 106.000
375 mm INV. IN = 106.250
GRATE ELEV. = 112.000
- 15 STA 202+00.0- RT 9.00 m TO LT 9.00 m
CONSTRUCT 14.0 m x 375 mm RCP
CONSTRUCT CD-S @ +00.0- LT 9.00 m
375 mm INV. OUT = 107.000
GRATE ELEV. = 112.000

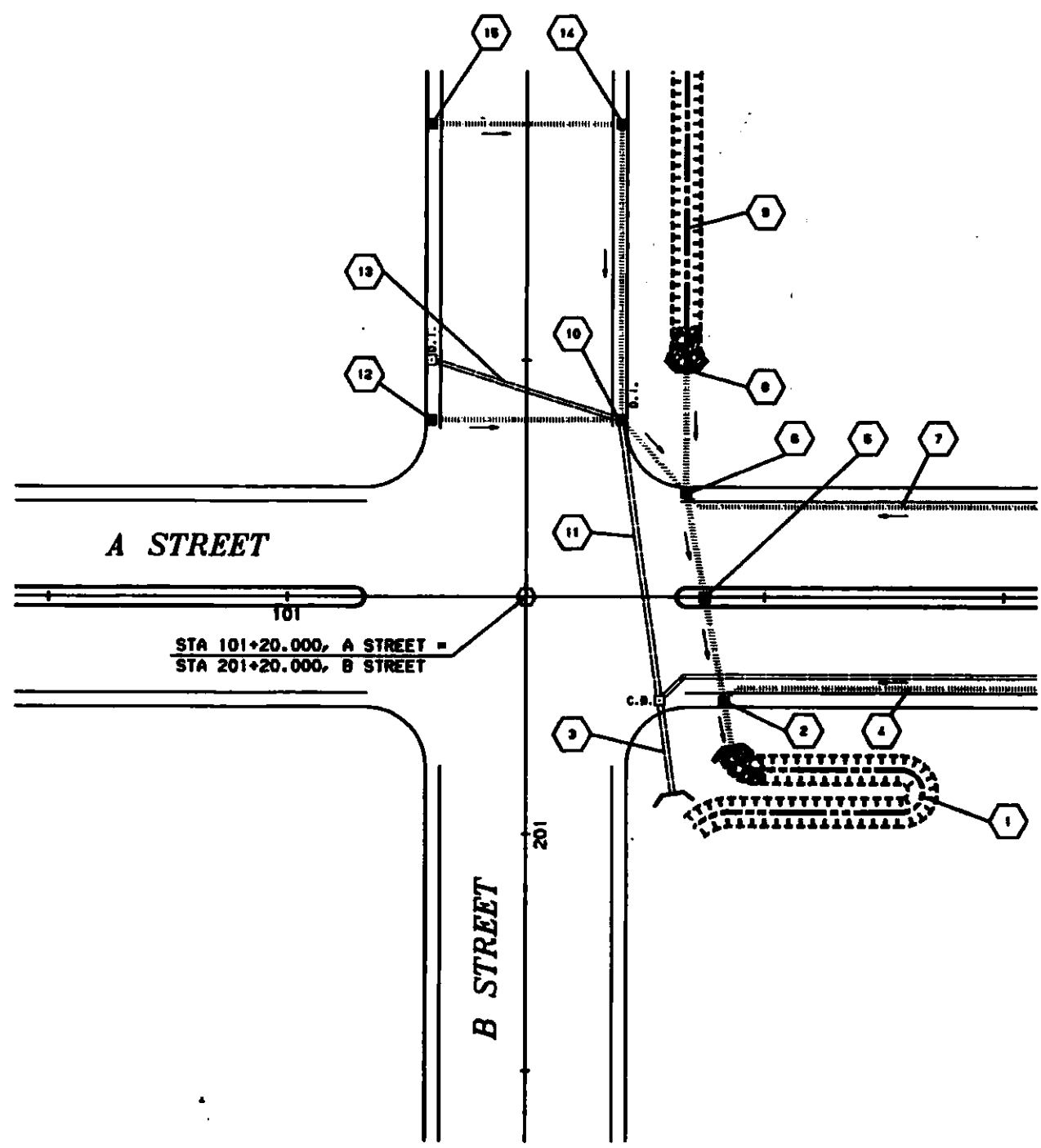

STATE OF NEW HAMPSHIRE					
DEPARTMENT OF TRANSPORTATION • BUREAU OF HIGHWAY DESIGN					
DRAINAGE SAMPLE					
WINDOW NO.	.F&B FILENAME	FEDERAL PROJECT NO.	STATE PROJECT NO.	SHEET NO.	TOTAL SHEETS
DRSAMP	DRSAMP				