

TYPE 'A'
ITEM 609.812

NOTE: TO BE USED ONLY WHEN CALLED FOR ON PLANS.

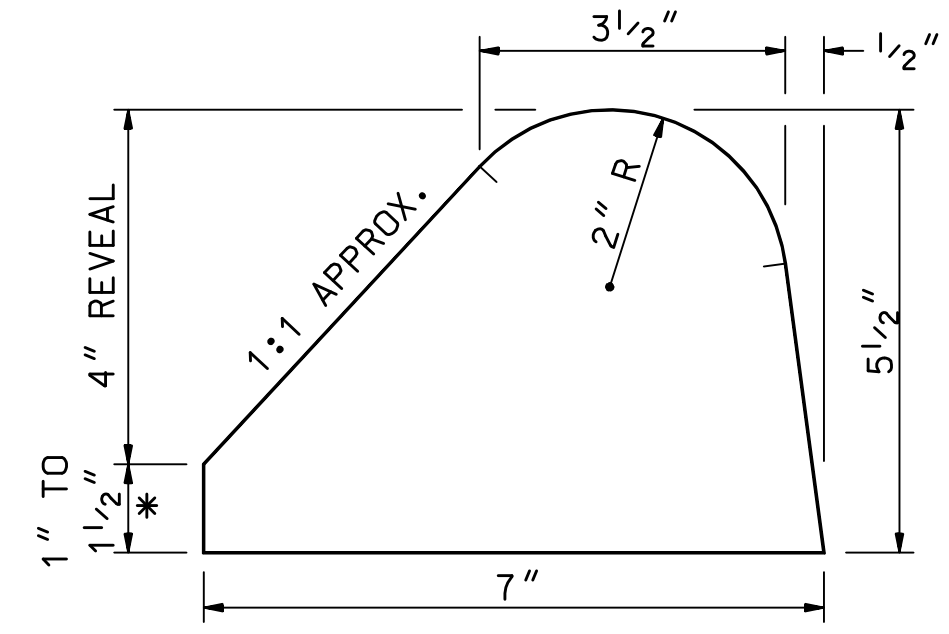

TYPE 'B' (4" REVEAL)
ITEM 609.811

NOTE: NORMALLY USED UNDER GUARDRAIL. SEE PLATE 2 FOR PLACEMENT DETAIL.

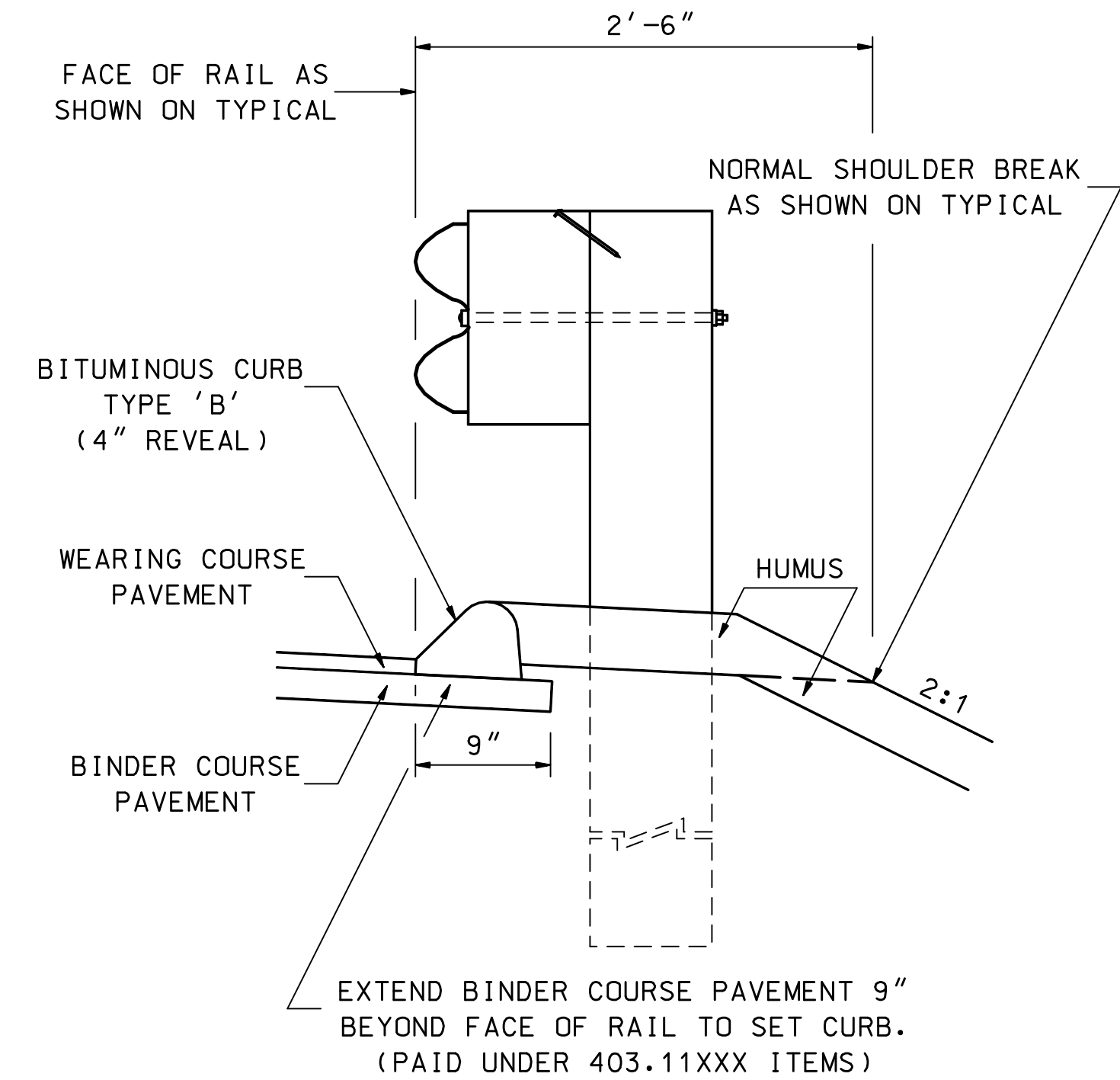

BITUMINOUS CURB PLACEMENT UNDER BEAM GUARDRAIL

BITUMINOUS CURB

REV. DATE	PLATE
06-16-2010	1
	STANDARD
	CR-2

REV. DATE	PLATE
06-16-2010	2
	STANDARD
	CR-2

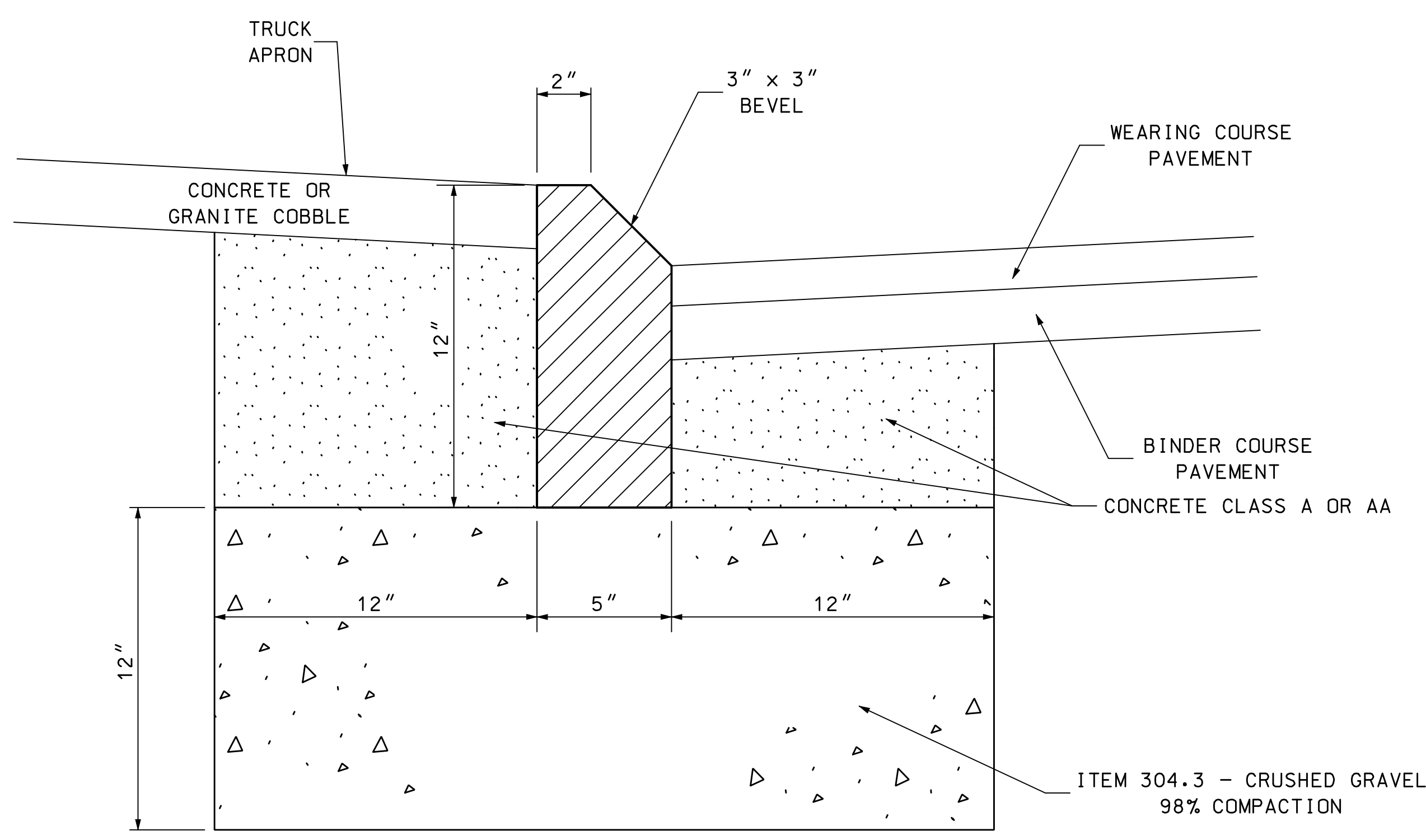

**ITEM 609.01123 - STRAIGHT GRANITE CURB, 12" HIGH
W/ 3" X 3" BEVELED MOUNTABLE EDGE**

ROUNDBOUT TRUCK APRON CURB

REV. DATE	PLATE
06-16-2010	3
	STANDARD
	CR-2

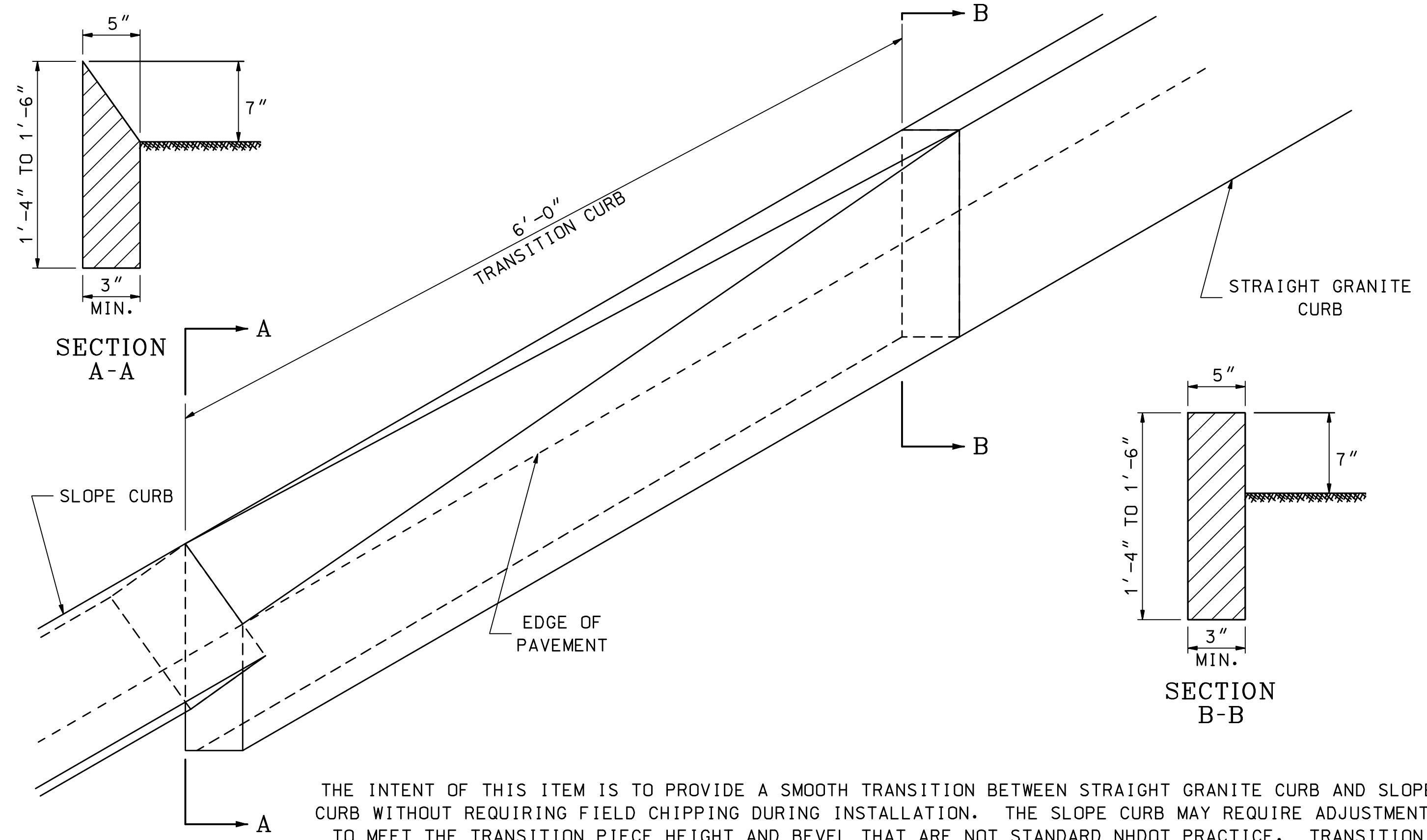

THE INTENT OF THIS ITEM IS TO PROVIDE A SMOOTH TRANSITION BETWEEN STRAIGHT GRANITE CURB AND SLOPE CURB WITHOUT REQUIRING FIELD CHIPPING DURING INSTALLATION. THE SLOPE CURB MAY REQUIRE ADJUSTMENTS TO MEET THE TRANSITION PIECE HEIGHT AND BEVEL THAT ARE NOT STANDARD NHDOT PRACTICE. TRANSITION SLOPE CURB TO STANDARD REVEAL AS QUICKLY AS POSSIBLE TO PROVIDE FOR THIS SMOOTH TRANSITION.

STRAIGHT TO SLOPE CURB TRANSITION

REV. DATE	PLATE
06-16-2010	4
	STANDARD
	CR-2

STANDARD NO. CR-2

REVISION DATE
07-13-2001
06-16-2010

***DGN FILE NAME**
CR-2

STANDARD PLANS



STANDARD NO. CR-2