

REVISION DATE
02-26-2010
11-05-2010

*DGN FILE NAME GR-16

STANDARD PLANS

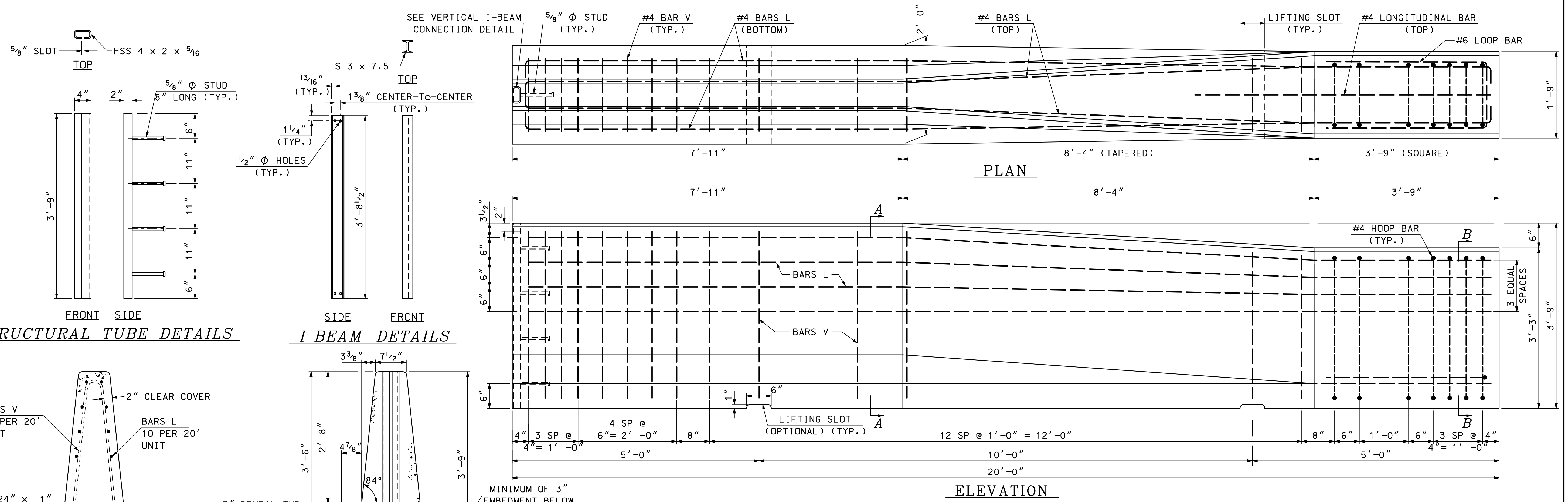

FRONT SIDE
STRUCTURAL TUBE DETAILS

SIDE FRONT
I-BEAM DETAILS

PLAN

ELEVATION

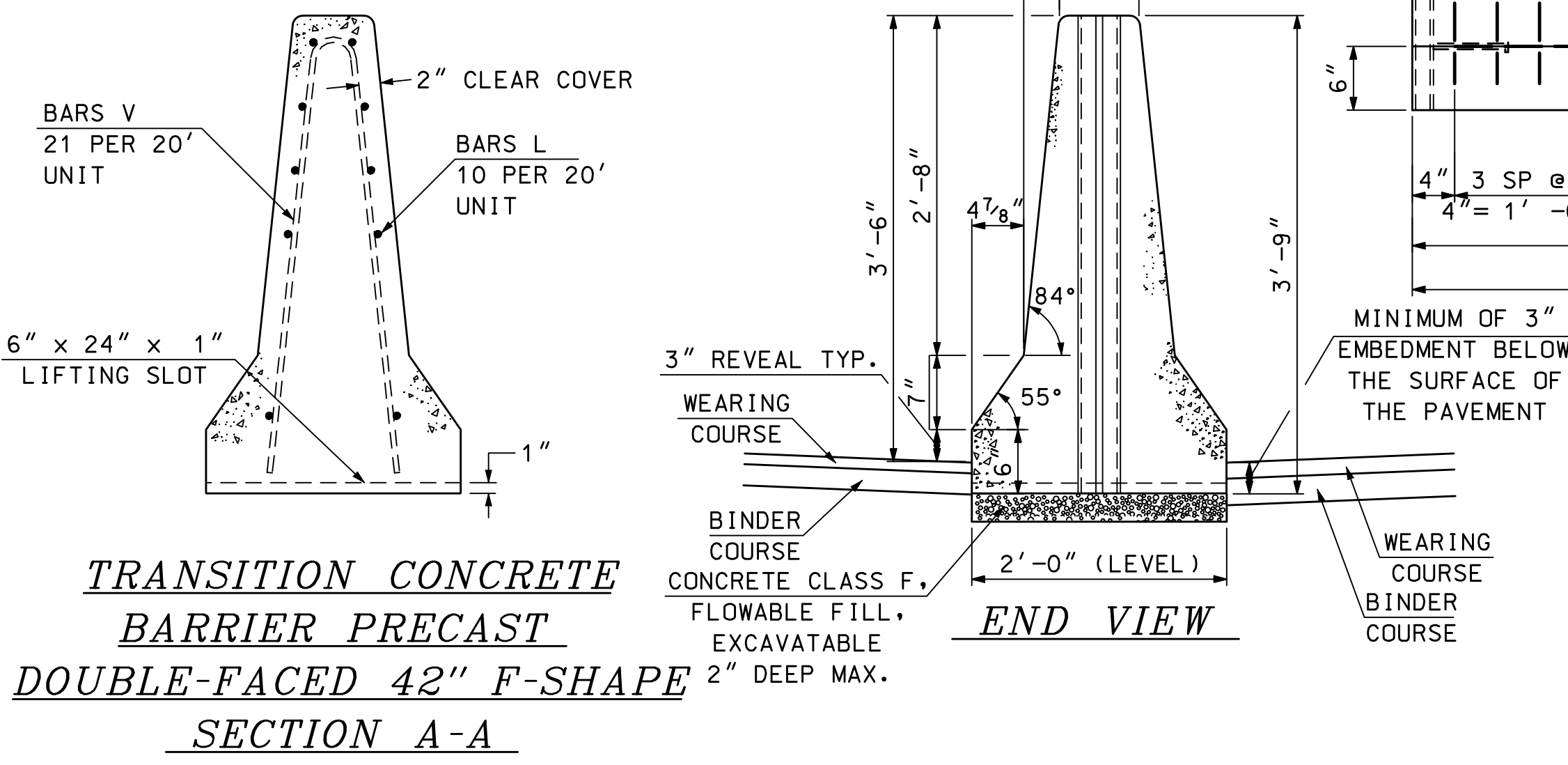

TRANSITION CONCRETE
BARRIER PRECAST
DOUBLE-FACED 42" F-SHAPE
SECTION A-A

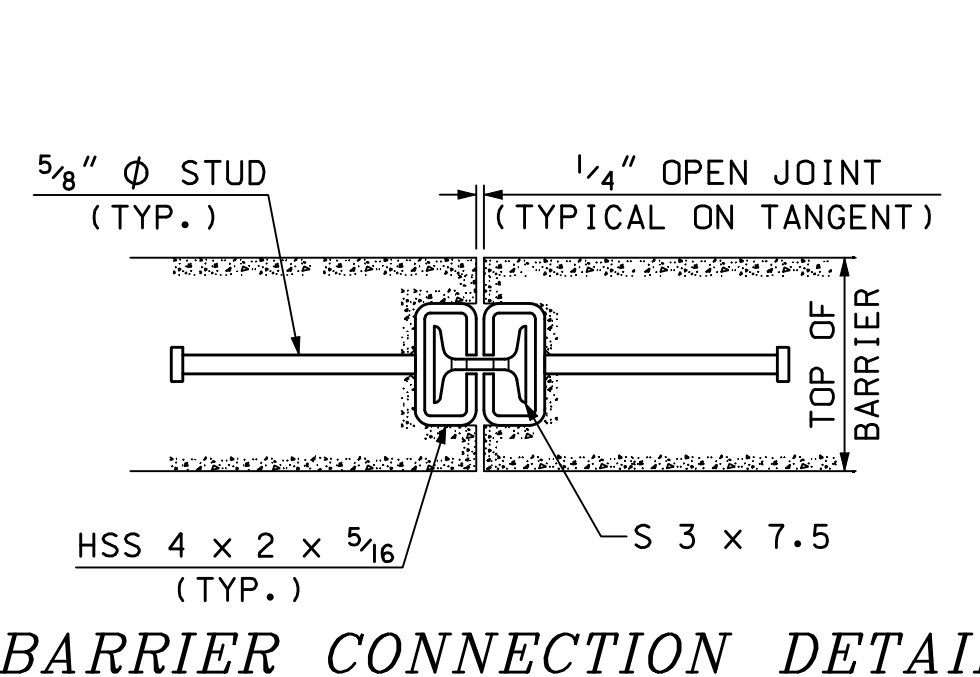

BARRIER CONNECTION DETAIL

GENERAL NOTES

1. THE CONCRETE BARRIER DETAILS, AS SHOWN ON THIS SHEET, ARE IN COMPLIANCE WITH THE REQUIREMENTS OF NCHRP REPORT 350, TL 4.
2. I-BEAMS AND STRUCTURAL TUBES SHALL BE GALVANIZED AFTER FABRICATION.
3. STUD WELDING SHALL BE IN ACCORDANCE WITH ITEM 547.
4. SLOT IN STRUCTURAL TUBE SHALL BE CUT WITH MECHANICALLY GUIDED MEANS TO A SMOOTH, UNIFORM SURFACE MEETING A SURFACE ROUGHNESS OF 1000 MICROINCHES OR BETTER (ANSI B46.1).
5. PAID FOR UNDER APPROPRIATE 606 ITEMS, OR AS SHOWN ON PLANS.

MATERIAL NOTES

1. THE BARRIERS SHALL BE LIGHT COLORED CLASS "AA" CONCRETE HAVING A MINIMUM 28 DAY COMPRESSION STRENGTH OF 4,000 PSI. BARRIERS SHALL HAVE A SMOOTH UNIFORM SURFACE FREE OF DEFECTS AND IRREGULARITIES. CASTING DATE SHALL BE SHOWN ON BARRIER. ALL EXPOSED EDGES OF CONCRETE SHALL BE CHAMFERED 3/4", UNLESS NOTED OTHERWISE.
2. ALL REINFORCING STEEL SHALL BE AASHTO M31 (ASTM-A615) GRADE 60, EPOXY COATED. REINFORCEMENT SHOWN IS THE MINIMUM REQUIRED.
3. EACH BARRIER UNIT SHALL INCLUDE ONE S 3x7.5 AS SHOWN ON THIS PLAN SHEET.
4. SHOP DRAWINGS, SHALL INCLUDE REINFORCING SCHEDULE.
5. LEVELING PADS OR SHIMMING MATERIAL SHALL BE SUBSIDIARY TO THE BARRIER ITEM.

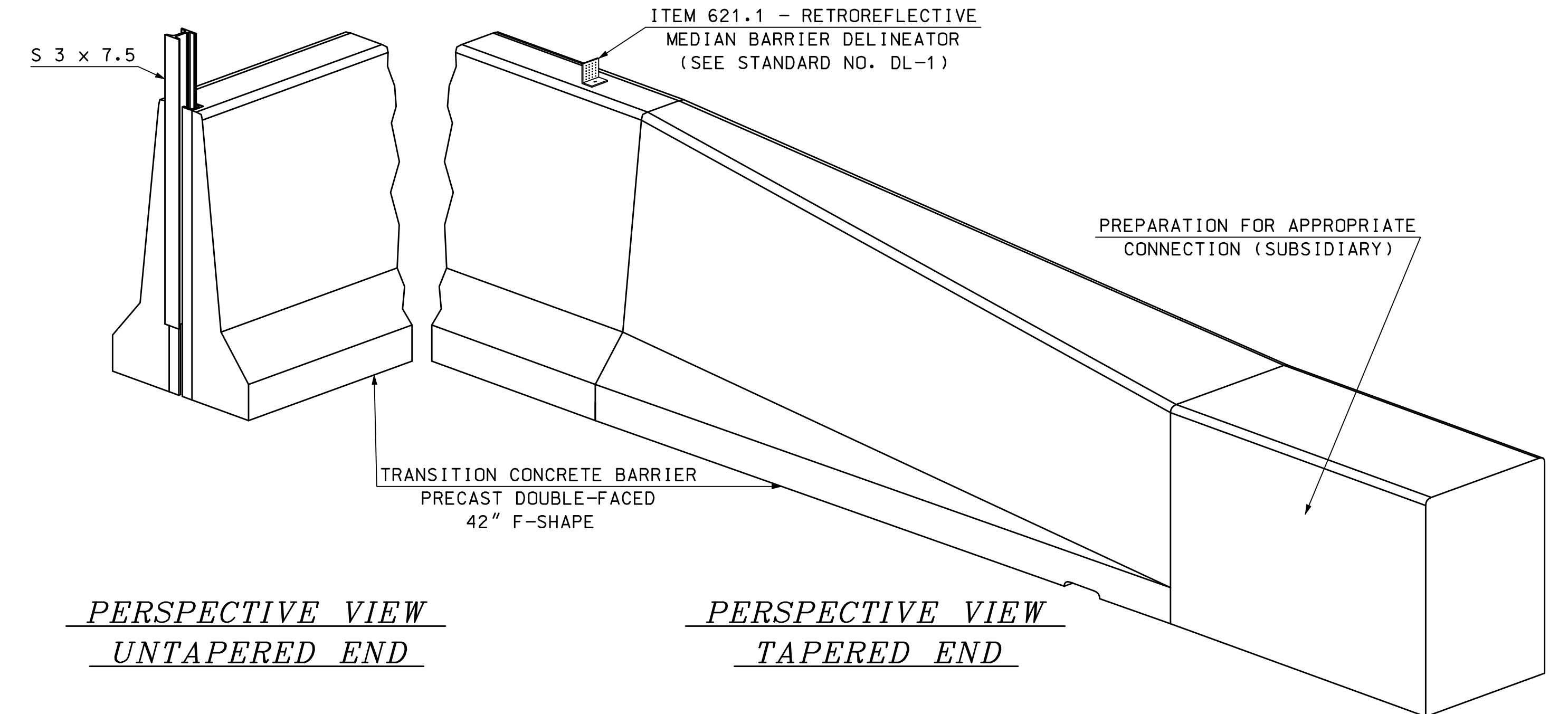

PERSPECTIVE VIEW
UNTAPERED END

PERSPECTIVE VIEW
TAPERED END

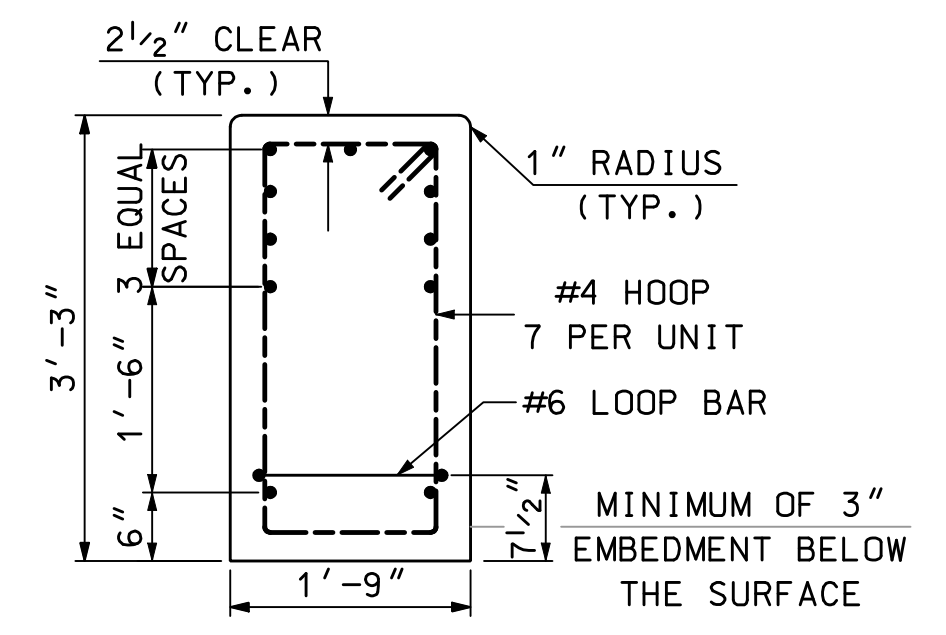

SECTION B-B
(MASONRY &
REINFORCEMENT)

GUARDRAIL STANDARD
TRANSITION
CONCRETE BARRIER PRECAST
DOUBLE-FACED 42" F-SHAPE

