

REVISION DATE
07-13-2001
02-26-2010

*.DGN FILE NAME
PM-12

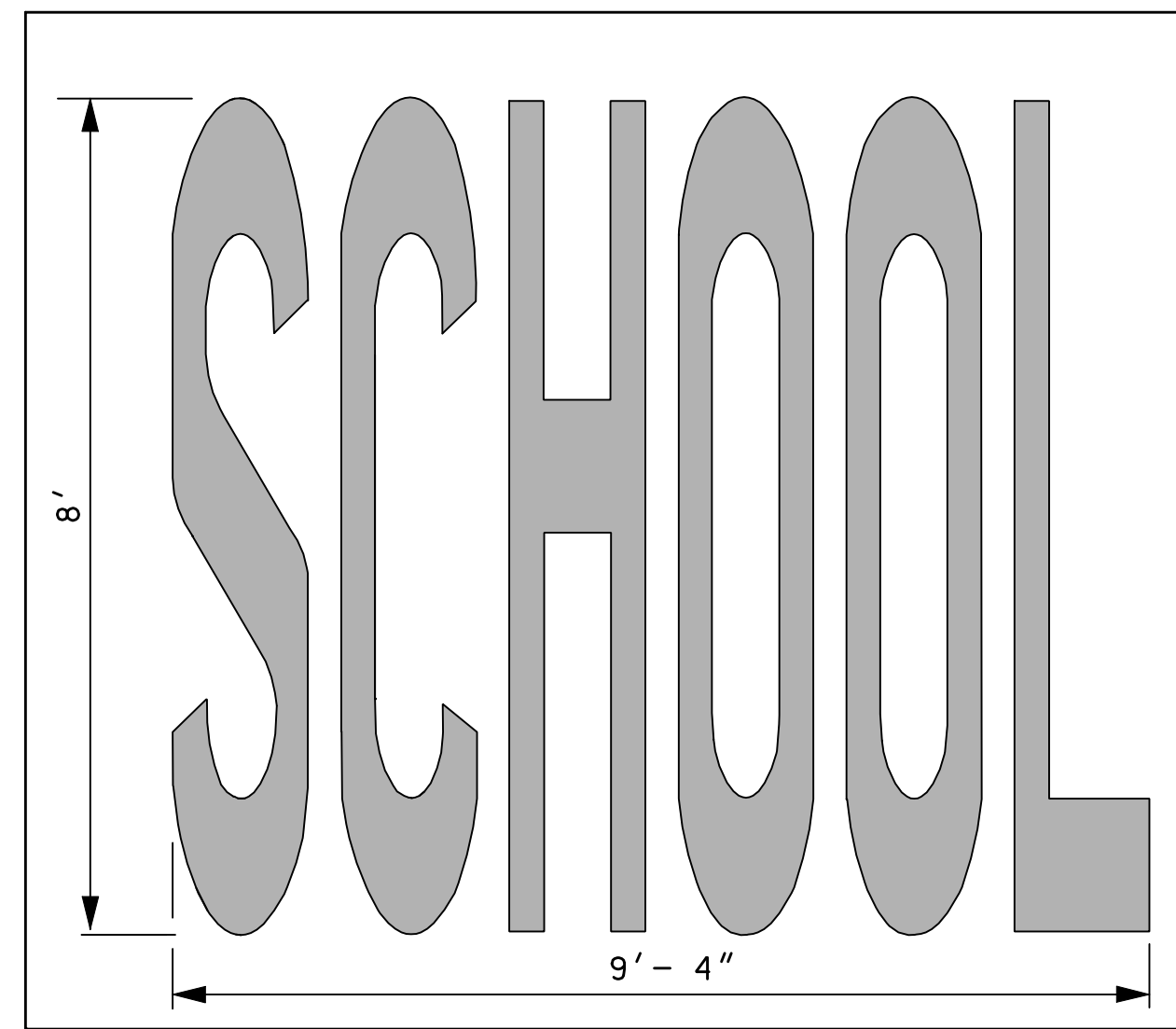

SCHOOL
PAY QUANTITY = 34.7 FT²

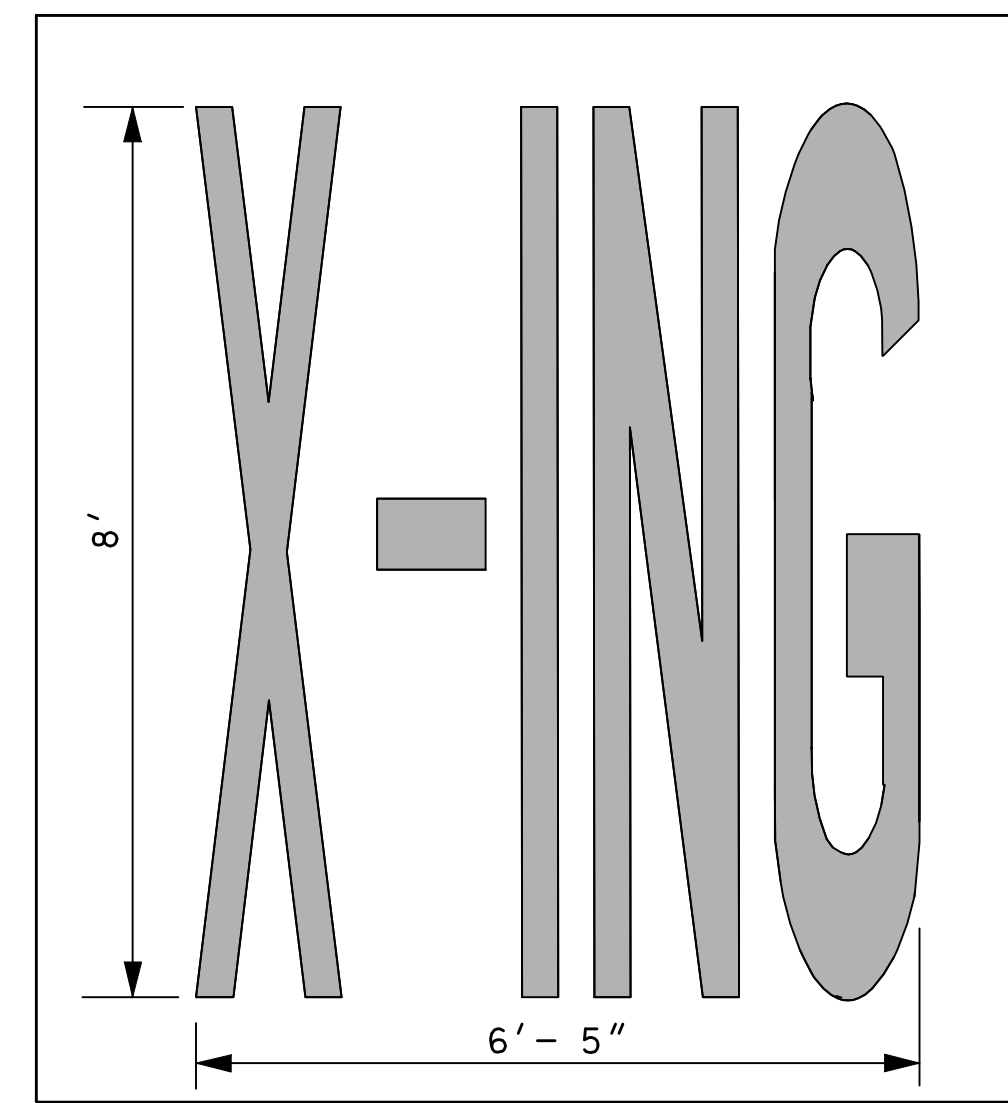

X-ING
PAY QUANTITY = 20.8 FT²

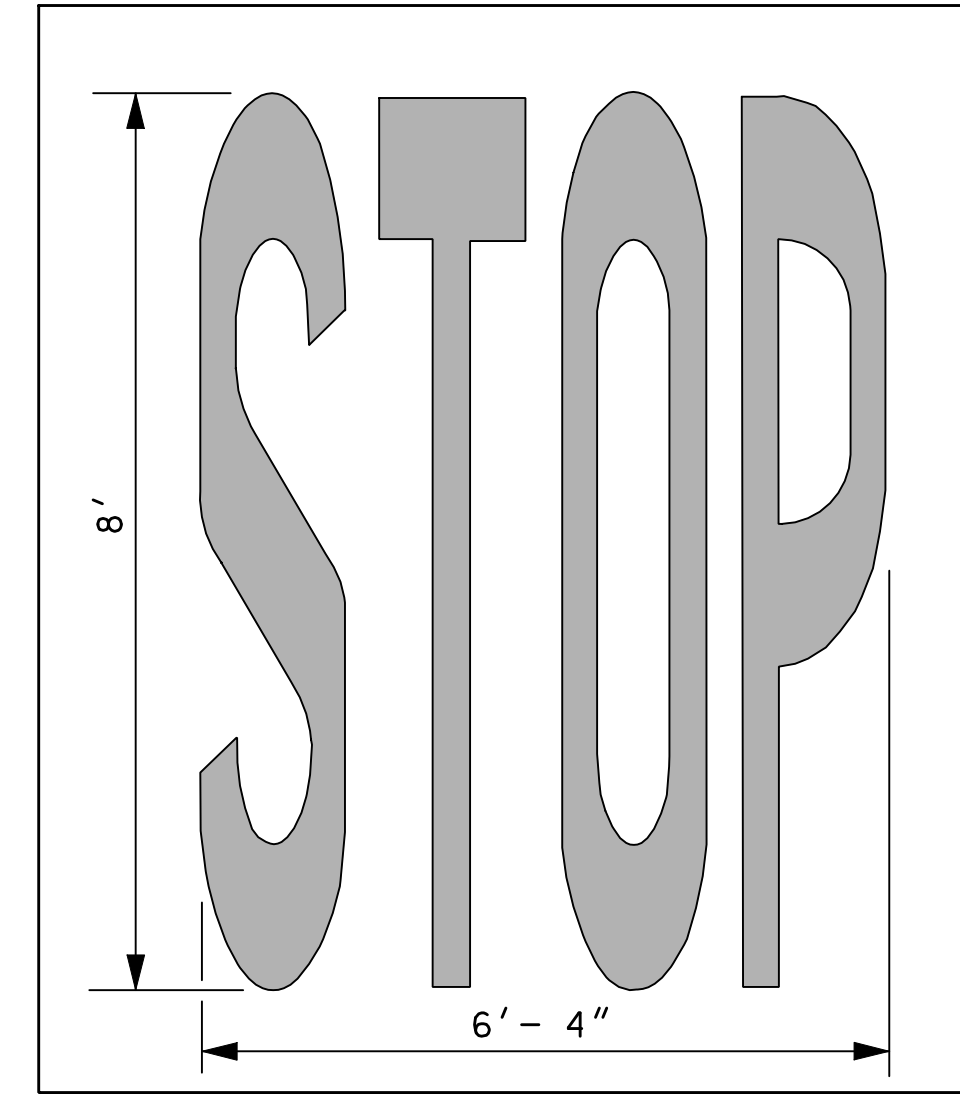

STOP
PAY QUANTITY = 22.2 FT²

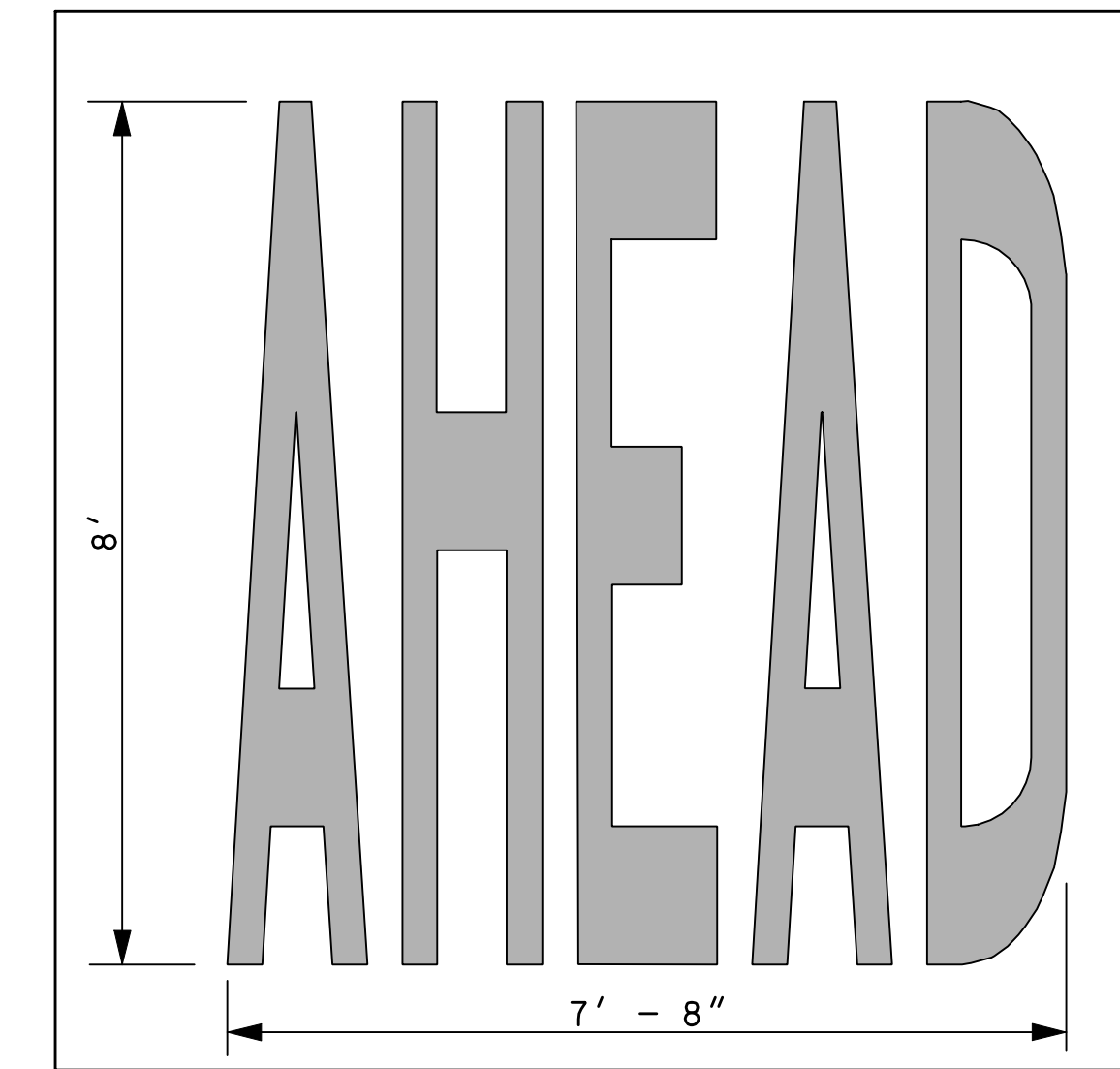

AHEAD
PAY QUANTITY = 31.3 FT²

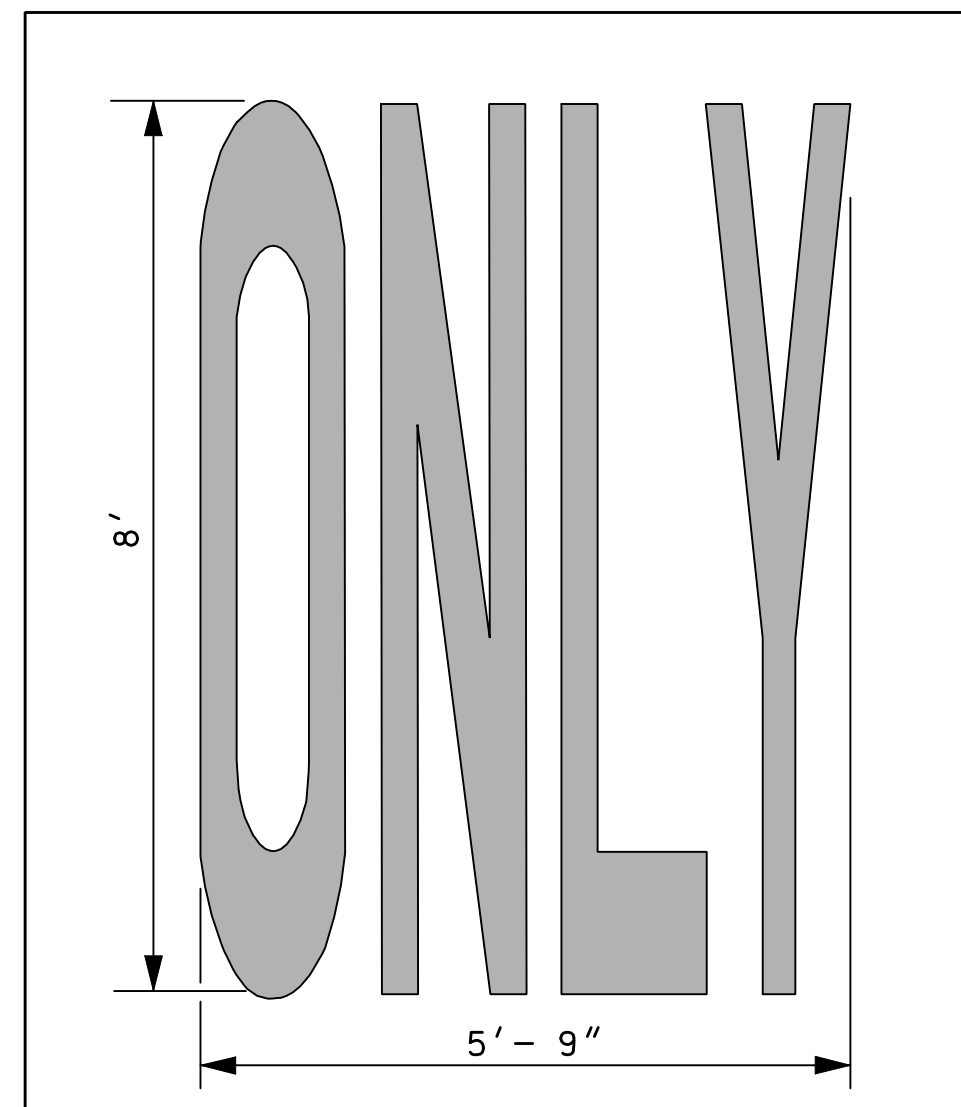

ONLY
PAY QUANTITY = 22.3 FT²

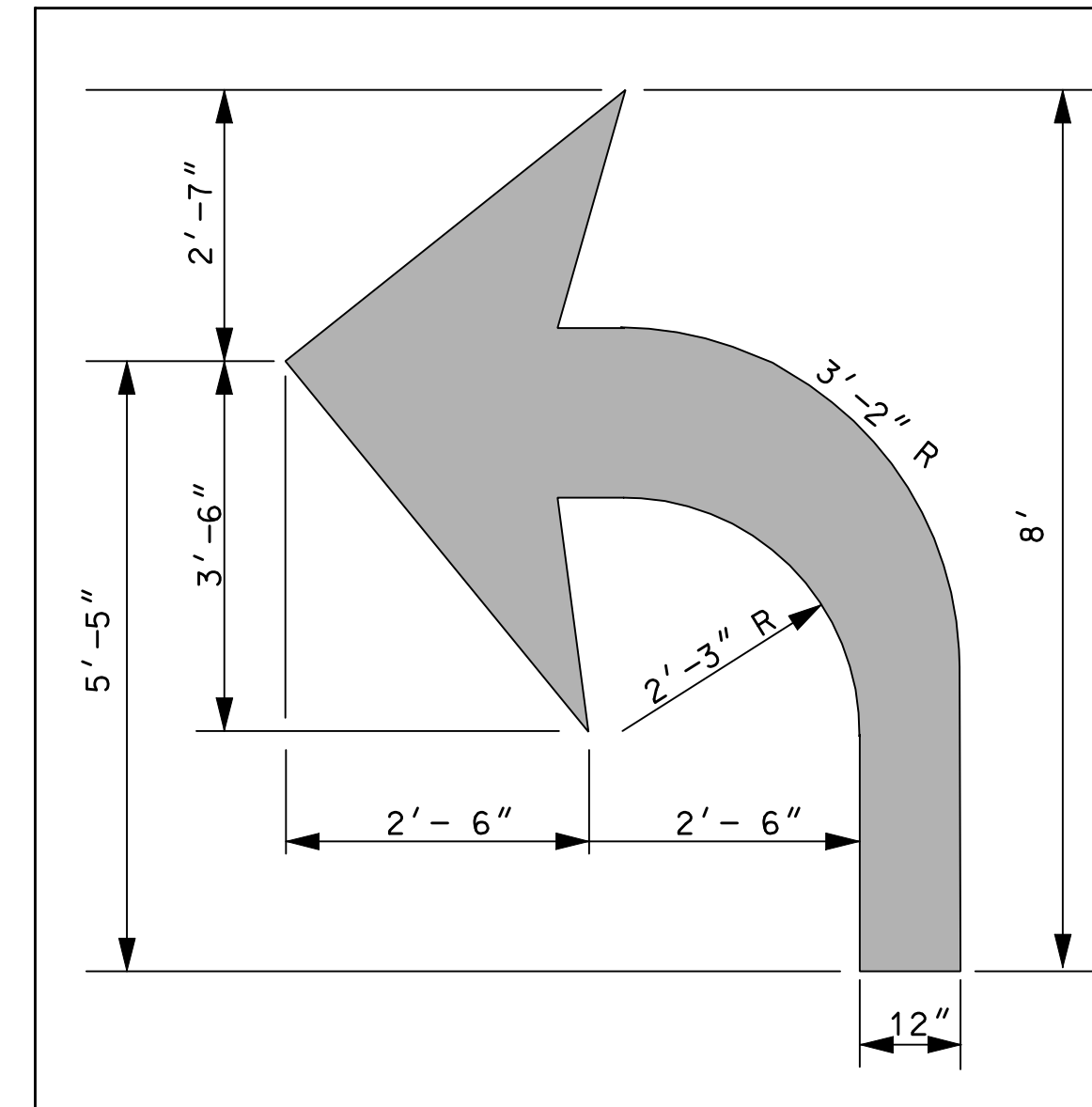

TURN ARROW
(RIGHT TURN OPPOSITE IN KIND)
PAY QUANTITY = 17.0 FT²

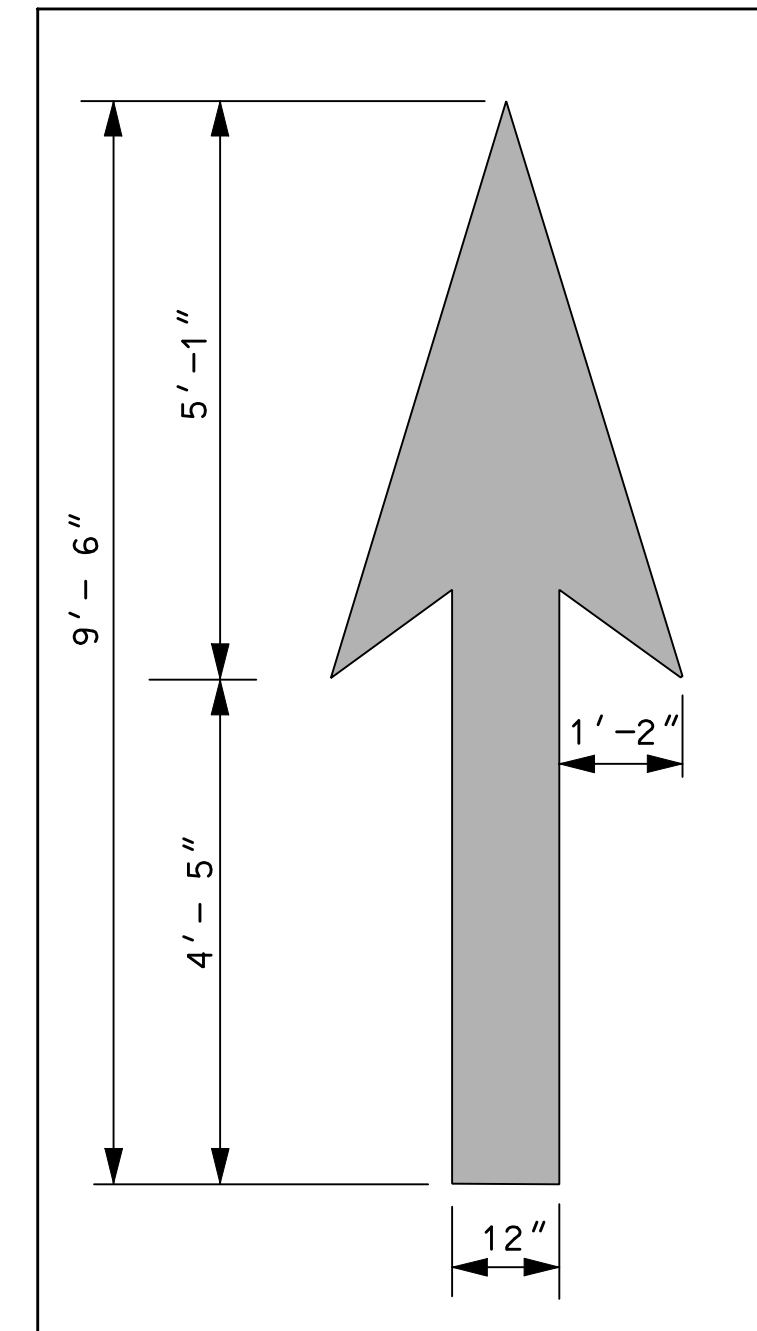

THROUGH (STRAIGHT ARROW)
PAY QUANTITY = 12.5 FT²

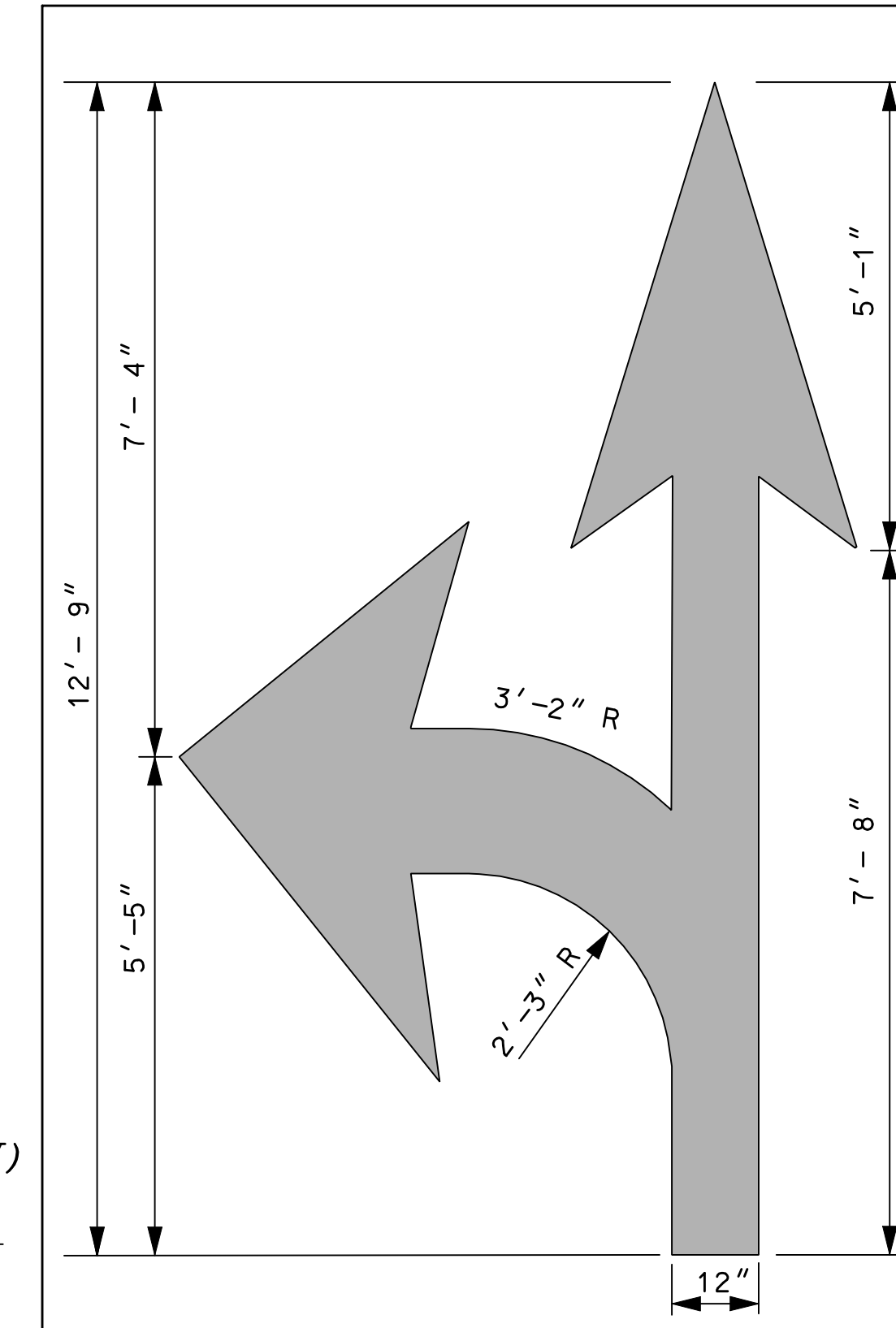

COMBINATION ARROW
PAY QUANTITY = 28.8 FT²

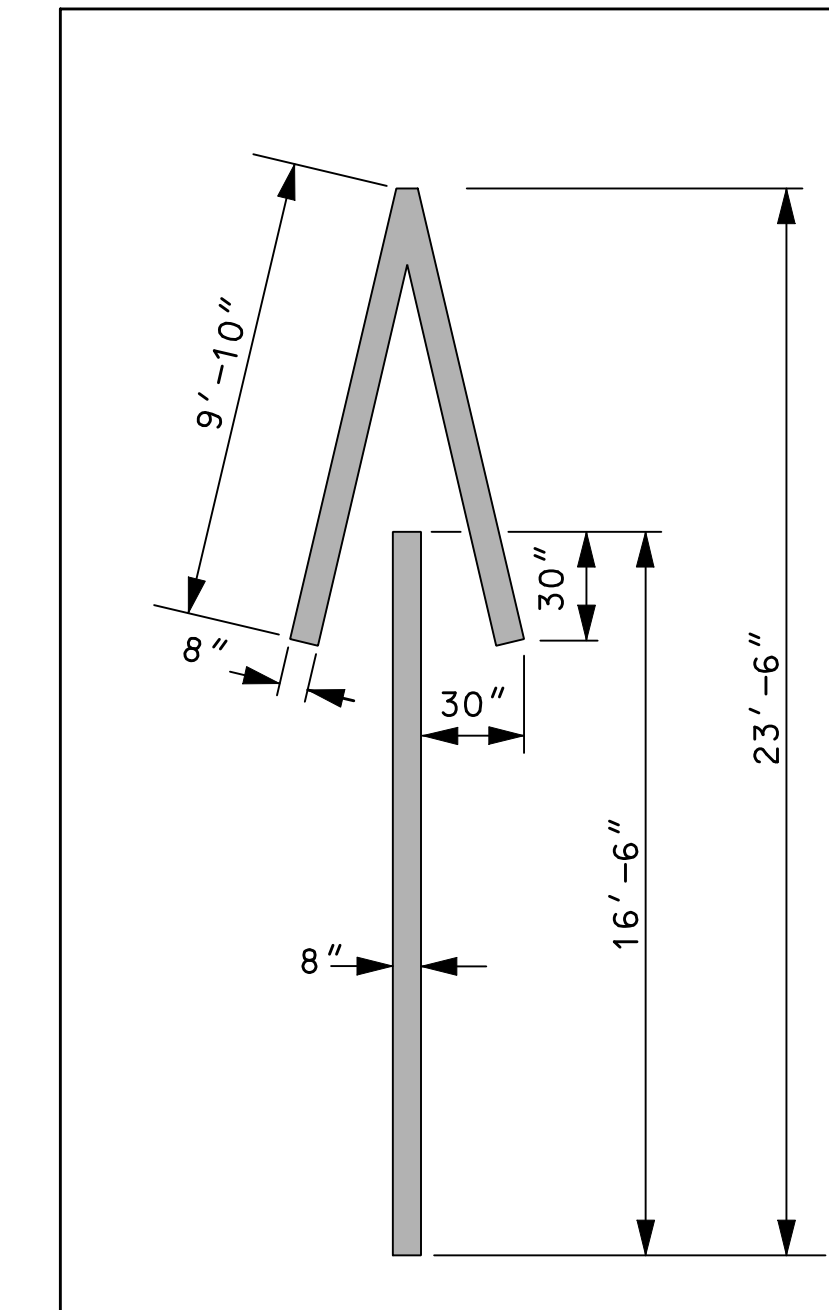

WRONG-WAY ARROW
PAY QUANTITY = 24.1 FT²

GENERAL NOTES

1. ALL WORDS AND SYMBOLS SHALL BE RETROREFLECTIVE WHITE AND SHALL CONFORM TO THE LATEST VERSION OF THE MUTCD.
2. MULTI-WORD MESSAGES SHALL READ "UP"; THAT IS, THE FIRST WORD SHALL BE NEAREST THE APPROACHING DRIVER.
3. THE WORD "ONLY" SHALL NOT BE USED WITH THROUGH OR COMBINATION ARROWS, AND SHALL NOT BE USED ADJACENT TO A BROKEN LANE LINE. A WORD/SYMBOL SHALL PRECEED THE WORD "ONLY".
4. COMBINATION ARROWS MAY BE COMPRISED OF 2 SINGLE ARROWS (e.g. TURN AND THROUGH ARROWS). HOWEVER, THE SHAFTS OF THE ARROWS SHALL COINCIDE AS SHOWN.
5. PREFORMED WORDS AND SYMBOLS SHALL BE PRE-CUT BY THE MANUFACTURER.
6. WRONG-WAY ARROWS SHALL NOT BE SUBSTITUTED FOR THROUGH ARROWS.
7. ALL STOP BARS, WORDS, SYMBOLS AND ARROWS SHALL BE THERMOPLASTIC.