

NEW HAMPSHIRE DEPARTMENT OF TRANSPORTATION



BUREAU OF BRIDGE DESIGN



DESCRIPTION:

**ASPHALTIC PLUG EXPANSION JOINT -
DECK PANEL - STEEL GIRDER**

DATE REVISED:

7/31/2023

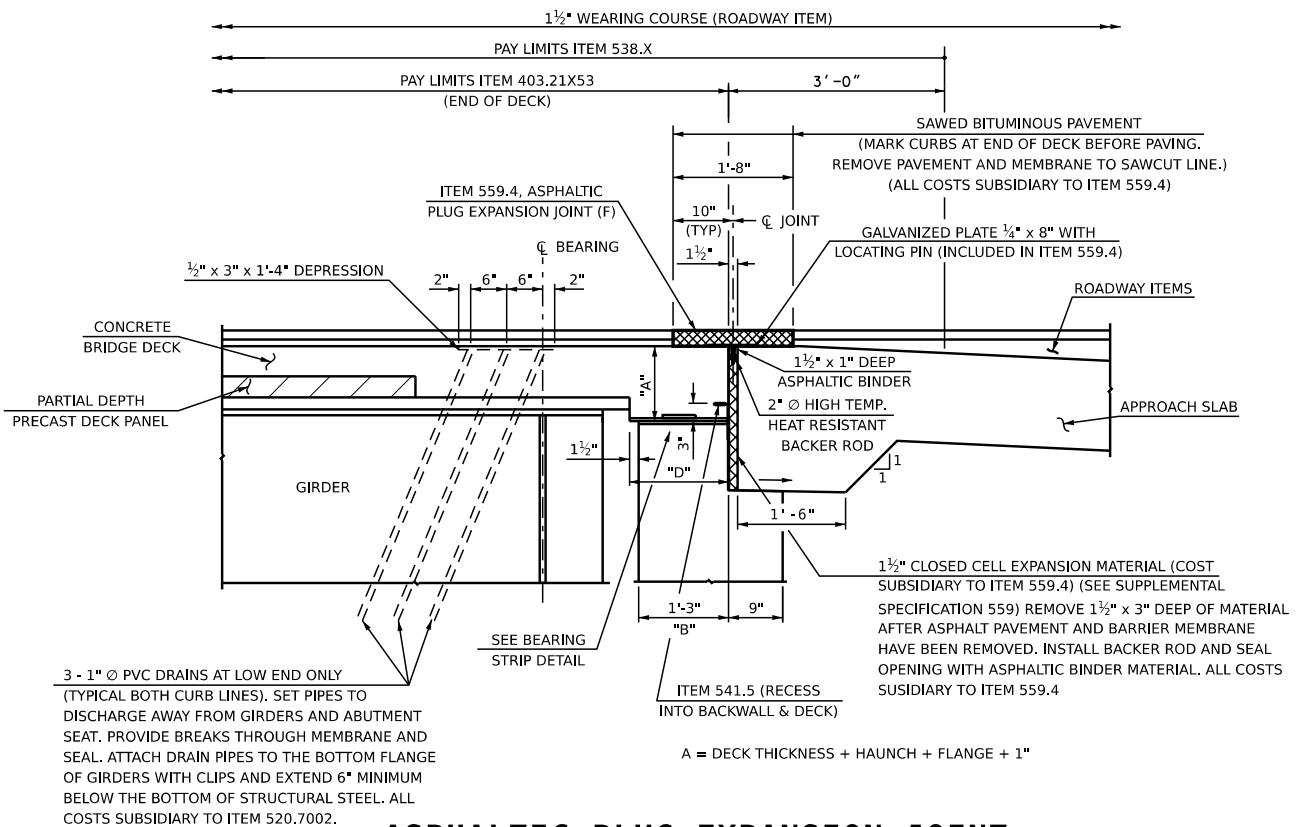

ASPHALTIC PLUG EXPANSION JOINT (DECK PANEL STEEL GIRDER - EXPANSION END)

NOT TO SCALE

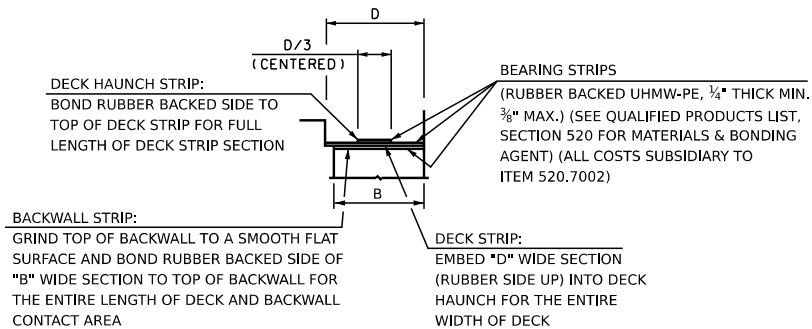

BEARING STRIP DETAIL

NOT TO SCALE

**MODIFY TO
FIT PROJECT**

NEW HAMPSHIRE DEPARTMENT OF TRANSPORTATION



BUREAU OF BRIDGE DESIGN



DESCRIPTION:

ASPHALTIC PLUG EXPANSION JOINT - STEEL GIRDER

DATE REVISED:

7/31/2023

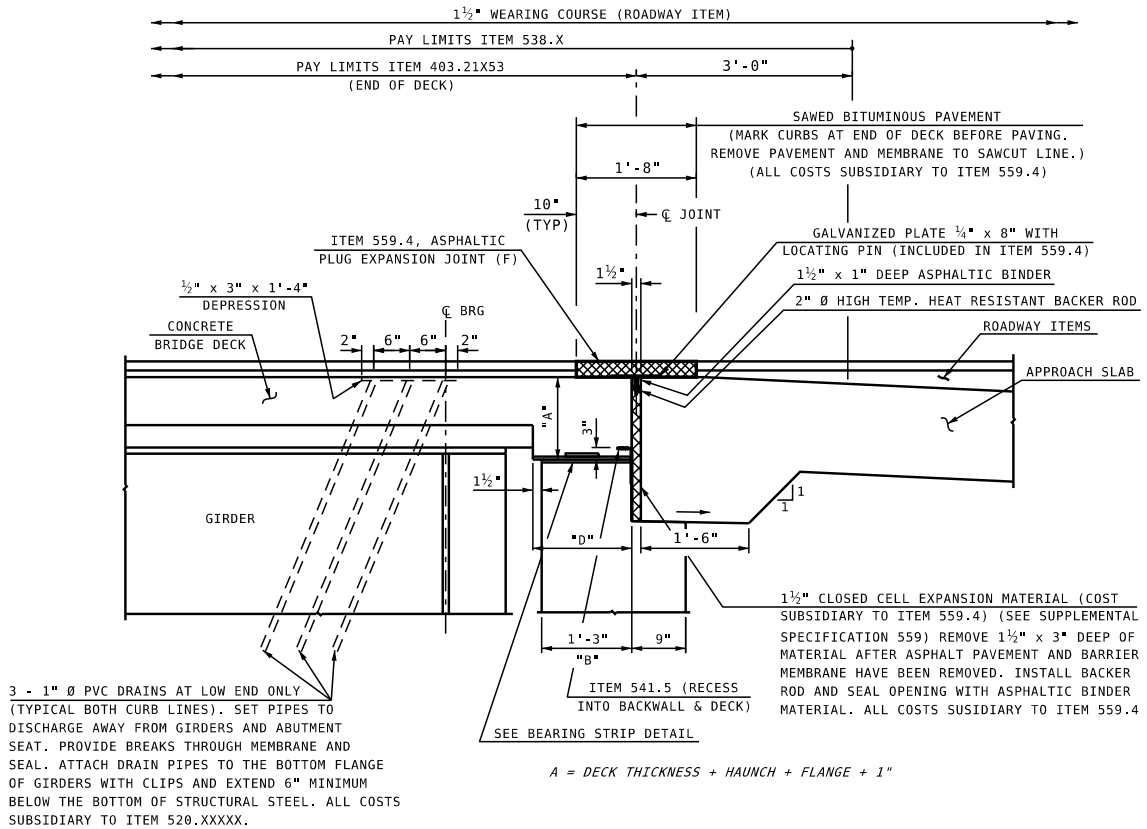

ASPHALTIC PLUG EXPANSION JOINT (APPROACH SLAB - EXPANSION END)

NOT TO SCALE

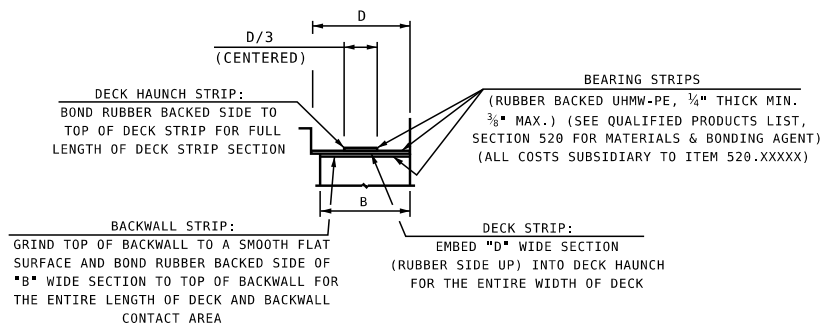

BEARING STRIP DETAIL

NOT TO SCALE

MODIFY TO
FIT PROJECT

NEW HAMPSHIRE DEPARTMENT OF TRANSPORTATION



BUREAU OF BRIDGE DESIGN



DESCRIPTION:

ASPHALTIC PLUG EXPANSION JOINT - JOINT REHABILITATION

DATE REVISED:

7/31/2023

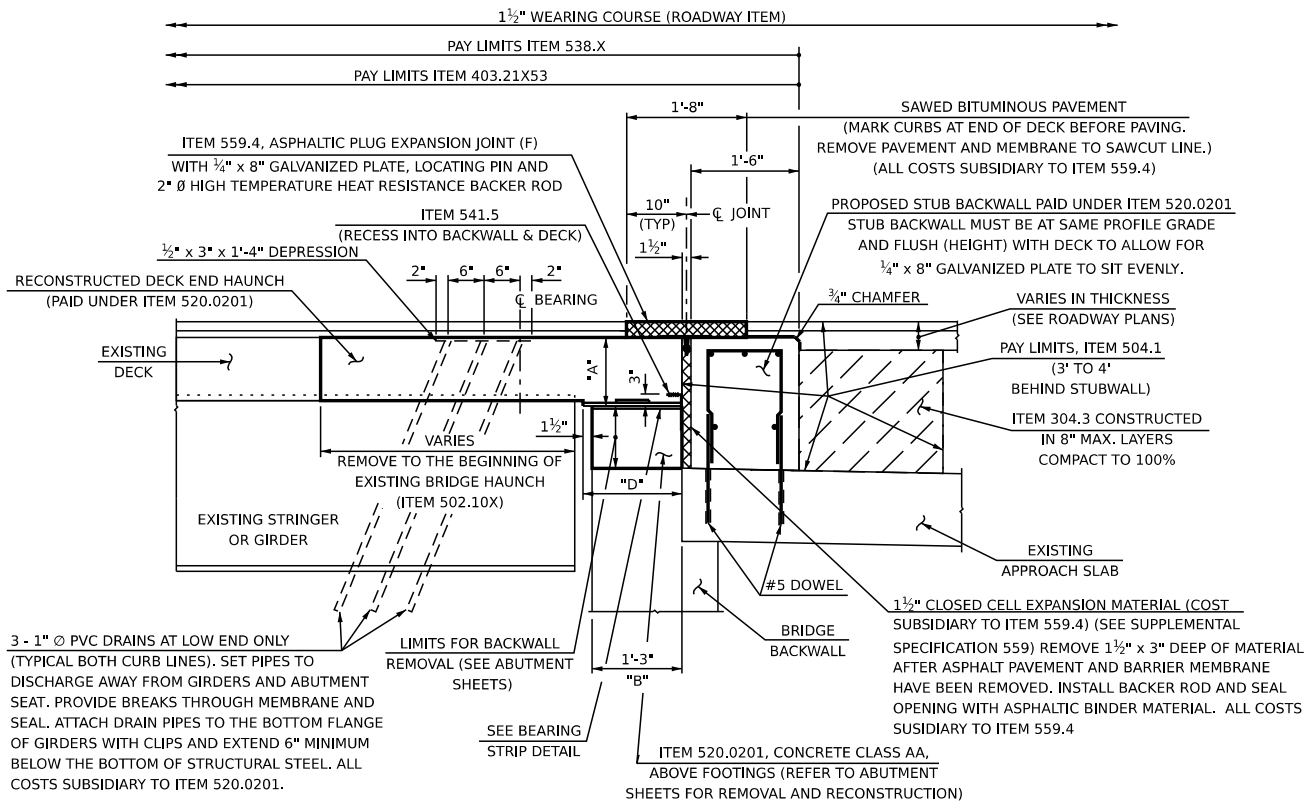

$$A = \text{DECK THICKNESS} + \text{HAUNCH} + \text{FLANGE} + 1"$$

ASPHALTIC PLUG EXPANSION JOINT (STUB WALL - EXPANSION END)

NOT TO SCALE

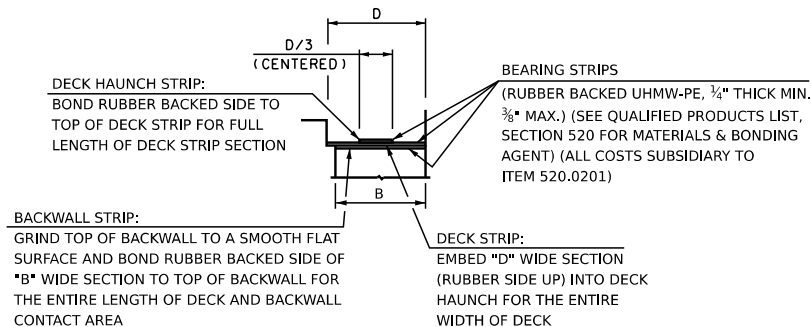

BEARING STRIP DETAIL

NOT TO SCALE

MODIFY TO
FIT PROJECT

NEW HAMPSHIRE DEPARTMENT OF TRANSPORTATION



BUREAU OF BRIDGE DESIGN



DESCRIPTION: ASPHALTIC PLUG EXPANSION JOINT -
CONCRETE GIRDER

DATE REVISED:
7/31/2023

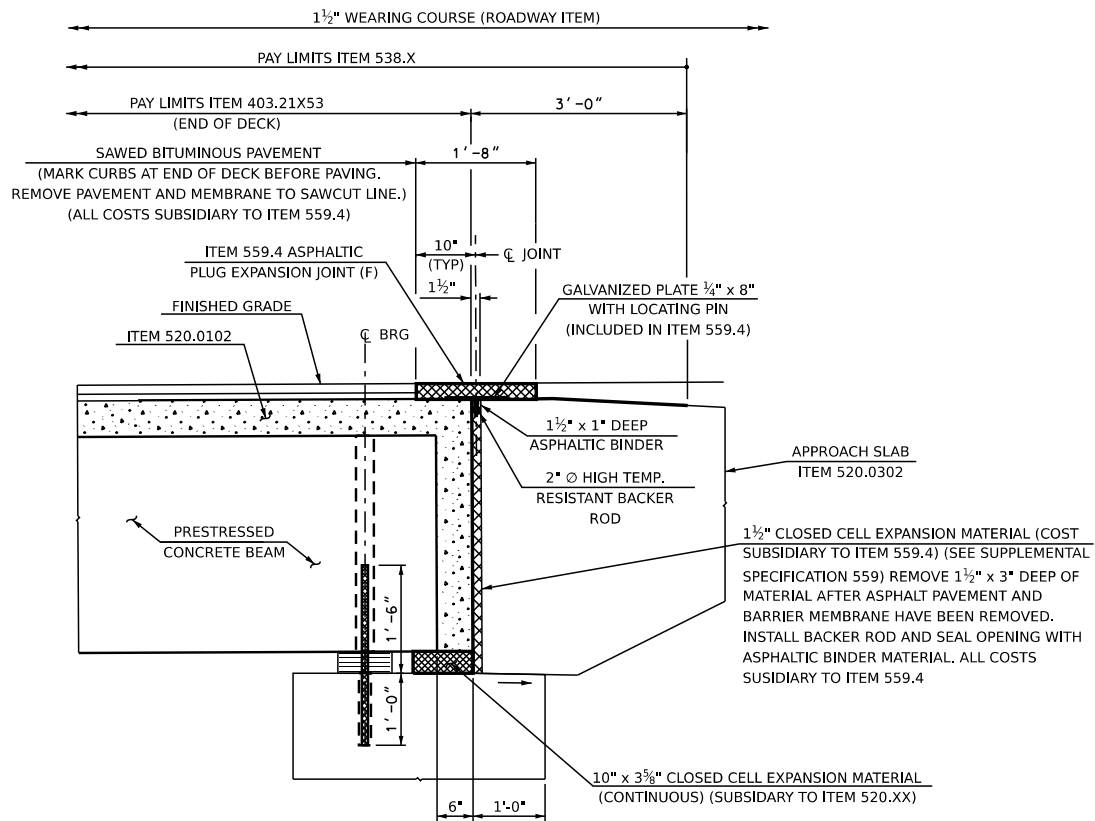

ASPHALTIC PLUG EXPANSION JOINT (APPROACH SLAB - EXPANSION END)

MODIFY TO
FIT PROJECT

NEW HAMPSHIRE DEPARTMENT OF TRANSPORTATION



BUREAU OF BRIDGE DESIGN



DESCRIPTION: ASPHALTIC PLUG EXPANSION JOINT -
CURB DETAIL

DATE REVISED:
2/8/16

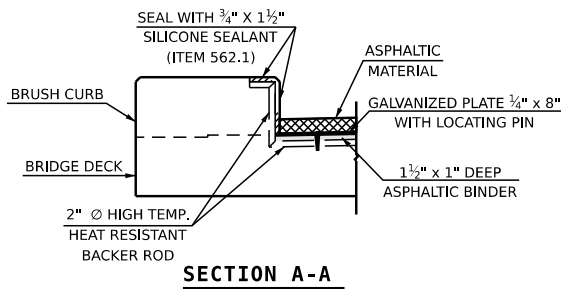
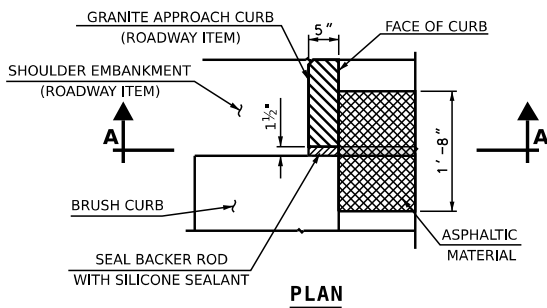

**ASPHALTIC PLUG EXPANSION JOINT (F)
ITEM 559.4 (CURB DETAIL)**

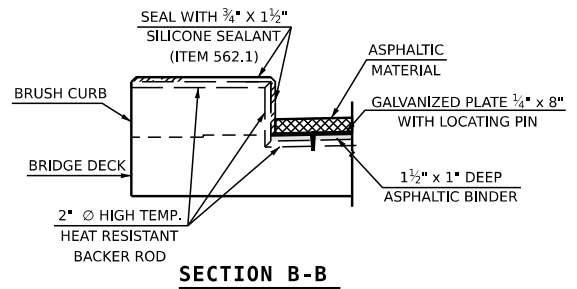
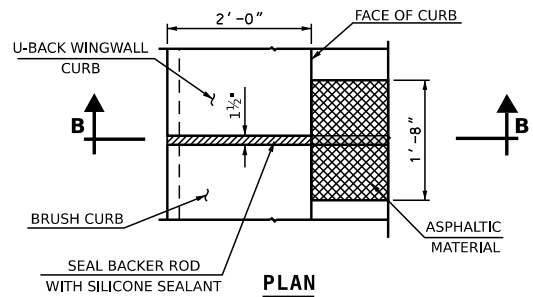

**ASPHALTIC PLUG EXPANSION JOINT (F)
ITEM 559.4 (U-BACK WINGWALL
CURB DETAIL)**

MODIFY TO
FIT PROJECT