

Chapter 1610

Traffic Barriers

- 1610.01 General
- 1610.02 References
- 1610.03 Definitions
- 1610.04 Project Criteria
- 1610.05 Barrier Design
- 1610.06 Beam Guardrail
- 1610.07 Cable Barrier
- 1610.08 Concrete Barrier
- 1610.09 Special-Use Barriers
- 1610.10 Bridge Traffic Barriers
- 1610.11 Other Barriers
- 1610.12 Documentation

1610.01 General

The Washington State Department of Transportation (WSDOT) uses traffic barriers to reduce the overall severity of collisions that occur when a vehicle leaves the traveled way. Consider whether a barrier is preferable to the recovery area it replaces. In some cases, installation of a traffic barrier may result in more collisions, as it presents an object that can be struck. Barriers are designed so that such encounters might be less severe and not lead to secondary or tertiary collisions. However, when impacts occur, traffic barriers are not guaranteed to redirect vehicles without injury to the occupants or additional collisions.

Barrier performance is affected by the characteristics of the types of vehicles that collide with them. For example, motor vehicles with large tires and high centers of gravity are commonplace on our highways and they are designed to mount obstacles. Therefore, they are at greater risk of mounting barriers or of not being decelerated and redirected as conventional vehicles would be.

When barriers are crash-tested, it is impossible to replicate the innumerable variations in highway conditions. Therefore, barriers are crash-tested under standardized conditions. These standard conditions were previously documented in National Cooperative Highway Research Program (NCHRP) Report 350. These guidelines have been updated and are now presented in the *Manual for Assessing Safety Hardware (MASH)*.

Barriers are not placed with the assumption that the system will restrain or redirect all vehicles in all conditions. It is recognized that the designer cannot design a system that is foolproof or will address every potential collision situation. Instead, barriers are placed with the assumption that, under normal conditions, they might provide lower potential for occupant deceleration and vehicle redirection for given roadside collisions when compared to a location without barrier.

Traffic barriers do not prevent collisions or injuries from occurring. They are intended to lower the potential severity for crash outcomes based on the conditions for which they are installed. Consequently, barriers should not be used unless a reduced crash frequency and severity potential is likely. No matter how well a barrier system is designed, optimal performance is dependent on drivers' proper use, maintenance, and operation of their vehicles and the proper use of vehicle restraint systems. At the time of installation, the ultimate choice of barrier type and placement is made by gaining an understanding of site and traffic conditions, having a thorough understanding of and using the criteria presented in Chapters 1600 and 1610, and using engineering judgment.

1610.02 References

1610.02(1) Design Guidance

Bridge Design Manual, M 23-50, WSDOT

Roadside Design Guide, AASHTO, 2011

Standard Plans for Road, Bridge, and Municipal Construction (Standard Plans), M 21-01, WSDOT

Traffic Manual, M 51-02, WSDOT

1610.02(2) Supporting Information

NCHRP 350, TRB, 1993

Manual for Assessing Safety Hardware (MASH), AASHTO, 2009

Determining Length of Need. This e-learning course for WSDOT employees covers the “Length of Need,” which is a calculation of how much longitudinal barrier is necessary to shield objects on the roadside. Request this training via the web-based Learning Management System.

1610.03 Definitions

Refer to the *Design Manual Glossary* for many of the terms used in this chapter.

1610.04 Project Criteria

Any project that introduces new barrier onto the roadside (including median) should be placed using full design level guidance (1610.04(2)(b)). This section identifies the barrier elements that are addressed according to notes in the Design Matrices in [Chapter 1100](#). Remove barrier that is not needed. Use the criteria in [Chapter 1600](#) as the basis for removal.

1610.04(1) Barrier Terminals and Transitions

Install, replace, or upgrade transitions as discussed in [1610.06\(6\)](#), Transitions and Connections.

Impact attenuator criteria can be found in [Chapter 1620](#), Impact Attenuator Systems. Concrete barrier terminal criteria can be found in [1610.08\(3\)](#).

When installing new terminals, consider extending the guardrail to meet the length-of-need criteria found in [1610.05\(5\)](#) as a spot safety enhancement, which is a modification to isolated roadway or roadside features that, in the engineer’s judgment, reduce potential for collision frequency or severity.

When the end of a barrier has been terminated with a small mound of earth, remove and replace with a crash-tested terminal, except as noted in [1610.09](#).

Redirectional landforms, also referred to as earth berms, were formerly installed to help mitigate collisions with fixed objects located in depressed medians and at roadsides. They were constructed of materials that provided support for a traversing vehicle. With slopes in the range of 2H:1V to 3H:1V, they were intended to redirect errant vehicles. The use of redirection landforms has been discontinued. Where redirection landforms currently exist as mitigation for a fixed object, provide alternative means of mitigation of the fixed object, such as remove, relocate, upgrade with crash-tested systems, or shield with barrier. Landforms may be used to provide a smooth surface at the base of a rock cut slope.

Replace guardrail terminals that do not have a crash-tested design with crash-tested guardrail terminals (see 1610.06(5), Terminals and Anchors). Common features of systems that do not meet current crash-tested designs include:

- No cable anchor.
- A cable anchored into concrete in front of the first post.
- Second post not breakaway (CRT).
- Design A end section (Design C end sections may be left in place—see the *Standard Plans* for end section details).
- Terminals with beam guardrail on both sides of the posts (two-sided).
- Buried guardrail terminals that slope down such that the guardrail height is reduced to less than 26 inches.

When the height of an existing terminal will be reduced to less than 26 inches from the ground to the top of the rail element, adjust the height to a minimum of 26 inches and a maximum of 28 inches. A rail height of 28 inches is desirable to accommodate future overlays. When adjusting terminals that are equipped with CRT posts, the top-drilled holes in the posts need to remain at the surface of the ground.

One terminal that was used extensively on Washington's highways was the Breakaway Cable Terminal (BCT). This system used a parabolic flare similar to the Slotted Rail Terminal (SRT) and a Type 1 anchor. (Type 1 anchor posts are wood set in a steel tube or a concrete foundation.) Replace BCTs on Interstate routes. On non-Interstate routes and Interstate ramps, BCTs that have at least a 3-foot offset may remain in place unless the guardrail run or anchor is being reconstructed or reset. (Raising the rail element is not considered reconstruction or resetting.)

Existing transitions that do not have a curb but are otherwise consistent with the designs shown in the *Standard Plans* may remain in place.

1610.04(2) Standard Run of Barrier

In Chapter 1100, the Design Matrices offer guidance on how to address standard barrier runs for different project types. A "Standard Run" of barrier consists of longitudinal barrier as detailed in the *Standard Plans*.

1610.04(2)(a) Barrier Height Criteria

For HMA Overlay Projects that will reduce the height of W-beam guardrail to less than 26 inches from the ground to the top of the rail element, adjust the height to a minimum of 26 inches and a maximum of 28 inches. A rail height of 28 inches is desirable to accommodate future overlays.

If Type 1 Alternate W-beam guardrail is present, raise the rail element after each overlay. If Type 1 Alternate is not present, raise the existing blockout up to 4 inches higher than the top of the existing post by boring a new hole in the post.

Overlays in front of safety shape concrete barriers can extend to the top of the lower, near-vertical face of the barrier before adjustment is necessary.

- Allow no more than 1 foot 1 inch from the pavement to the beginning of the top near-vertical face of the safety shape barriers.

- Allow no less than 2 feet 8 inches from the pavement to the top of the single-slope barrier.
- Allow no less than 35 inches to the center of the top cable for four-cable high-tension cable barriers.

Note: There are new high-tension cable barrier systems under development, which may change the selection and placement criteria. The Headquarters (HQ) Design Office will circulate guidance on these new developments as they are adopted as WSDOT policy.

1610.04(2)(b) Full Design Level (F)

When the full design level (F) is indicated the barrier is to meet the criteria in the following:

Chapter/Section	Subject
1600.05	Medians
1610.05(2)	Shy distance
1610.05(3)	Barrier deflections
1610.05(4)	Flare rate
1610.05(5)	Length of need
1610.05(6)	Median barrier selection and placement considerations
1610.06	Beam guardrail
1610.07	Cable barrier
1610.08	Concrete barrier

Examples of barriers that are not acceptable as a “Standard Run” are:

- W-beam guardrail with 12-foot-6-inch post spacing or no blockouts, or both.
- W-beam guardrail on concrete posts.
- Cable barrier on wood or concrete posts.
- Half-moon or C-shaped rail elements.

1610.04(3) Bridge Rail

When the Bridge Rail column of a Design Matrix applies to the project, the bridge rails, including crossroad bridge rail, are to meet the following criteria:

- Use an approved, crash-tested concrete bridge rail on new bridges or bridges to be widened. The *Bridge Design Manual* provides examples of typical bridge rails. Consult the HQ Bridge and Structures Office regarding bridge rail selection and design and for design of the connection to an existing bridge.
- An existing bridge rail on a highway with a posted speed of 30 mph or below may remain in place if it is not located on a bridge over a National Highway System (NHS) highway. When Type 7 bridge rail is present on a bridge over an NHS highway with a posted speed of 30 mph or below, it may remain in place regardless of the type of metal rail installed. Other bridge rails are to be evaluated for strength and geometrics. (See [1610.10](#) for guidance on retrofit techniques.)
- The Type 7 bridge rail is common. Type 7 bridge rails have a curb, a vertical-face parapet, and an aluminum top rail. The curb width and the type of aluminum top rail are factors in determining the adequacy of the Type 7 bridge rail, as shown in [Exhibit 1610-1](#). Consult the HQ Bridge and Structures Office for assistance in evaluating other bridge rails.

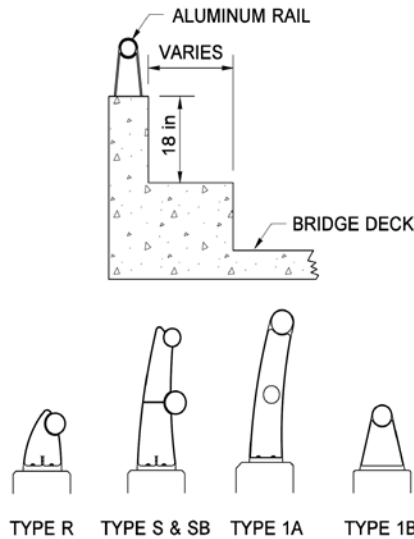

Aluminum Rail Type	Curb Width	
	9 Inches or Less	Greater Than 9 Inches*
Type R, S, or SB	Bridge rail adequate	Bridge rail adequate
Type 1B or 1A	Bridge rail adequate	Upgrade bridge rail
Other	Consult the HQ Bridge and Structures Office	

*When the curb width is greater than 9 inches, the aluminum rail must be able to withstand a 5 kip load.

Type 7 Bridge Rail Upgrade Criteria
Exhibit 1610-1

1610.05 Barrier Design

When selecting a barrier, consider the flexibility, cost, and maintainability of the system. It is generally desirable to use the most flexible system possible to minimize damage to the impacting vehicle and injury to the vehicle’s occupant(s). However, since nonrigid systems sustain more damage during an impact, the exposure of maintenance crews to traffic might be increased with the more frequent need for repairs.

Maintenance costs for concrete barrier are lower than for other barrier types. In addition, deterioration due to weather and vehicle impacts is less than most other barrier systems. Unanchored precast concrete barrier can usually be realigned or repaired when moved from its alignment. However, heavy equipment may be necessary to reposition or replace barrier segments. Therefore, in medians, consider the shoulder width and the traffic volume when determining the acceptability of unanchored precast concrete barrier versus rigid concrete barrier.

Drainage, alignment, and drifting snow or sand are considerations that can influence the selection of barrier type. Beam guardrail and concrete barrier can contribute to snow drifts. Consider long-term maintenance costs associated with snow removal at locations prone to snow drifting. Slope flattening is recommended when the safety benefit justifies the additional cost to eliminate the need for the barrier. Cable barrier is not an obstruction to drifting snow and can be used if slope flattening is not feasible.

With some systems, such as concrete and beam guardrail, additional shoulder widening or slope flattening is common. However, selection of these types of barriers is sometimes limited due to the substantial environmental permitting and highway reconstruction needs. Permits issued under the SEPA and NEPA processes may lead to the use of a barrier design such as cable barrier, which has fewer potential environmental impacts and costs.

1610.05(1) Sight Distance

When selecting and placing a barrier system, consider the possible impact the barrier type and height may have on sight distance. In some cases, barriers may restrict the sight distances of road users entering the roadway, such as from road approaches, intersections, and other locations. In these cases, the barrier may need to be adjusted to meet the required sight distance requirements at these locations.

1610.05(2) Shy Distance

Provide 2 feet of additional widening for shy distance when a barrier is to be installed in areas where the roadway is to be widened and the shoulder width will be less than 8 feet. This shy distance is not needed when the section of roadway is not being widened or the shoulders are at least 8 feet wide. (See criteria in [Chapter 1140](#) for exceptions.)

1610.05(3) Barrier Deflections

Expect all barriers except rigid barriers (such as concrete bridge rails) to deflect when hit by an errant vehicle. The amount of deflection is primarily dependent on the stiffness of the system. However, vehicle speed, angle of impact, and weight also affect the amount of barrier deflection. For flexible and semirigid roadside barriers, the deflection distance is designed to help prevent the impacting vehicle from striking the object being shielded. For unrestrained rigid systems (unanchored precast concrete barrier), the deflection distance is designed to help prevent the barrier from being knocked over the side of a drop-off or steep fill slope (2H:1V or steeper).

In median installations, design systems such that the anticipated deflection will not enter the lane of opposing traffic using deflection values that were determined from crash tests. When evaluating new barrier installations, consider the impacts where significant traffic closures are necessary to accomplish maintenance. Use a rigid system where deflection cannot be tolerated, such as in narrow medians or at the edge of bridge decks or other vertical drop-off areas. Runs of rigid concrete barrier can be cast in place or extruded with appropriate footings.

In some locations where deflection distance is limited, anchor precast concrete barrier. Unless the anchoring system has been designed to function as a rigid barrier, some movement can be expected and repairs may be more expensive. Use of an anchored or other deflecting barrier on top of a retaining wall without deflection distance provided requires approval from the HQ Design Office.

Refer to [Exhibit 1610-2](#) for barrier deflection design values when selecting a longitudinal barrier. The deflection distances for cable and beam guardrail are the minimum measurements from the face of the barrier to the fixed feature. The deflection distance for unanchored concrete barrier is the minimum measurement from the back edge of the barrier to the drop-off or slope break.

Barrier Type	System Type	Deflection
Cable barrier or beam guardrail, Types 20 and 21, on G-2 posts	Flexible	Up to 12 ft (face of barrier to object)
Beam guardrail, Types 1, 1a, 2, 10, and 31	Semirigid	3 ft (face of barrier to object)
Two-sided W-beam guardrail, Types 3 and 4	Semirigid	2 ft (face of barrier to object)
Permanent concrete barrier, unanchored	Rigid Unrestrained	3 ft ^[1] (back of barrier to object)
Temporary concrete barrier, unanchored	Rigid Unrestrained	2 ft ^[2] (back of barrier to object)
Precast concrete barrier, anchored	Rigid Anchored	6 inches (back of barrier to object)
Rigid concrete barrier	Rigid	No deflection

Notes:

[1] When placed in front of a 2H:1V or flatter fill slope, the deflection distance can be reduced to 2 feet.

[2] When used as temporary bridge rail, anchor all barrier within 3 feet of a drop-off.

Longitudinal Barrier Deflection

Exhibit 1610-2

1610.05(4) Flare Rate

Flare the ends of longitudinal barriers where practicable. The four functions of a flare are to:

- Locate the barrier and its terminal as far from the traveled way as feasible.
- Reduce the length of need.
- Redirect an errant vehicle.
- Minimize a driver's reaction to the introduction of an object near the traveled way.

Keeping flare rates as flat as practicable preserves the barrier's redirection performance and minimizes the angle of impact. However, it has been shown that an object (or barrier) close to the traveled way might cause a driver to shift laterally, slow down, or both. The flare reduces this reaction by gradually introducing the barrier so the driver does not perceive the barrier as an object to be avoided. The flare rates in [Exhibit 1610-3](#) are intended to satisfy the four functions listed above. More gradual flares may be used. Flare rates are offset parallel to the edge of the traveled way. Transition sections are not normally flared.

Posted Speed (mph)	Rigid & Rigid Anchored System	Unrestrained Rigid System	Semirigid System
65–70	20:1	18:1	15:1
60	18:1	16:1	14:1
55	16:1	14:1	12:1
50	14:1	12:1	11:1
45	12:1	11:1	10:1
40 or below	11:1	10:1	9:1

Longitudinal Barrier Flare Rates

Exhibit 1610-3

1610.05(5) Length of Need

The length of traffic barrier needed to shield a fixed feature (length of need) is dependent on the location and geometrics of the object, direction(s) of traffic, posted speed, traffic volume, and type and location of traffic barrier. When designing a barrier for a fill slope (see [Chapter 1600](#)), the length of need begins at the point where the need for barrier is recommended. For fixed objects and water, Exhibits [1610-10a](#) and [10b](#) show design parameters for determining the needed length of a barrier for both adjacent and opposing traffic on relatively straight sections of highway.

When barrier is to be installed on the outside of a horizontal curve, the length of need can be determined graphically, as shown in [Exhibit 1610-10c](#). For installations on the inside of a curve, determine the length of need as though it were straight. Also, consider the flare rate, barrier deflection, and barrier end treatment to be used.

When beam guardrail is placed in a median, consider the potential for impact from opposing traffic when conducting a length of need analysis. When guardrail is placed on either side of objects in the median, consider whether the trailing end of each run of guardrail will shield the leading end of the opposing guardrail. Shield the leading end when it is within the Design Clear Zone of opposing traffic (see [Exhibit 1610-10d](#)). This is also a consideration when objects are placed in the outer separations between the main line and collector-distributors.

Before the actual length of need is determined, establish the lateral distance between the proposed barrier installation and the object shielded. Provide a distance that is greater than or equal to the anticipated deflection of the longitudinal barrier. (See [Exhibit 1610-2](#) for barrier deflections.) Place the barrier as far from the edge of the traveled way as possible while maintaining the deflection distance.

If the end of the length of need is near an adequate cut slope, extend the barrier and embed it in the slope (see [1610.06\(5\)](#)). Avoid gaps of 300 feet or less. Short gaps are acceptable when the barrier is terminated in a cut slope. If the end of the length of need is near the end of an existing barrier, it is recommended that the barriers be connected to form a continuous barrier. Consider maintenance access issues when determining whether or not to connect barriers.

1610.05(6) Median Barrier Selection and Placement Considerations

The most desirable barrier installation uses the most flexible system appropriate for the location and one that is placed as far from the traveled way as practicable. Engineers are faced with the fact that barrier systems and vehicle fleets continue to evolve. What may be an optimal choice of barrier based on the majority of vehicles on the road today may not be the best selection for vehicles on the road in the foreseeable future. This continuum of change does not allow engineers to predict the future with any degree of certainty. Consequently, engineering decisions need to be made based on the most reliable and current information.

Engineers are constantly striving to develop more effective design features to improve highway safety. However, economics and feasibility do not permit new designs to be employed as soon as they are invented. The fact that a new design has been developed does not mean that the old design is unsafe. Although new designs may have been tested under controlled conditions, their performance under relevant applications may demonstrate unexpected performance aspects. Therefore there may be a need to modify application methods based on that practical experience.

Good engineering judgment is called for in determining the appropriate placement of barrier systems. Solutions may need to be arrived at while considering competing factors such as collision frequency and severity. As discussed previously, performance of the system relies on the interaction of the vehicle, driver, and system design at any given location. Additionally, the ability to access the system for maintenance and availability of parts plays into the final decision.

With median barriers, the deflection characteristics and placement of the barrier for a traveled way in one direction can have an impact on the traveled way in the opposing direction. In addition, the median slopes and environmental issues often influence the type of barrier that is appropriate.

In narrow medians, avoid placement of barrier where the design deflection extends into oncoming traffic. Narrow medians provide little space for maintenance crews to repair or reposition the barrier. Therefore, avoid installing deflecting barriers in medians that provide less than 8 feet from the edge of the traveled way to the face of the barrier.

In wider medians, the selection of barrier might depend on the slopes in the median. At locations where the median slopes are relatively flat (10H:1V or flatter), unrestrained precast concrete barrier, beam guardrail, and cable barrier can be used depending on the available deflection distance. At these locations, position the barrier as close to the center as possible so that the recovery distance can be maximized for both directions. There may be a need to offset the barrier from the flow line to avoid impacts to the drainage flow.

In general, cable barrier is recommended with medians that are 30 feet or wider. However, cable barrier may be appropriate for narrower medians if adequate deflection distance exists. In wide medians where the slopes are steeper than 10H:1V but not steeper than 6H:1V, cable barrier placed near the center of the median is preferable. For additional cable barrier placement guidance, see Exhibits 1610-13a through 13c. Place beam guardrail at least 12 feet from the slope breakpoint, as shown in Exhibit 1610-4. Do not use concrete barrier at locations where the foreslope into the face of the barrier is steeper than 10H:1V.

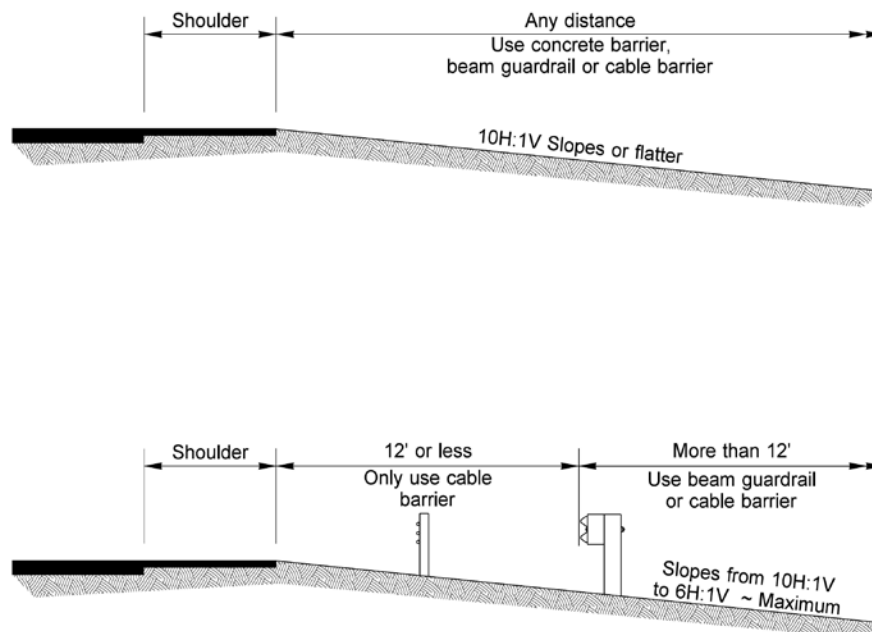

Traffic Barrier Locations on Slopes

Exhibit 1610-4

At locations where the roadways are on independent alignments and there is a difference in elevation between the roadways, the slope from the upper roadway might be steeper than 6H:1V. In these locations, position the median barrier along the upper roadway and provide deflection and offset distance as discussed previously. Barrier is generally not needed along the lower roadway except where there are fixed features in the median.

When W-beam barrier is placed in a median as a countermeasure for cross-median collisions, design the barrier to be struck from either direction of travel. For example, the installation of beam guardrail might be double-sided (Type 31-DS).

1610.05(7) Aesthetic Barrier Treatment

When designing a barrier for use on a Scenic Byway, consider barriers that are consistent with the recommendations in the associated corridor management plan (if one is available). Contact the region Landscape Architect or the Scenic Byways Coordinator in the HQ Highways and Local Programs Office to determine whether the project is on such a designated route. Low-cost options, such as using weathering steel beam guardrail (see [1610.06](#)) or cable barrier (see [1610.07](#)), might be feasible on many projects. Higher-cost options, such as steel-backed timber rail and stone guardwalls (see [1610.09](#)), might necessitate a partnering effort to fund the additional costs. Grants might be available for this purpose if the need is identified early in the project definition phase (see [Chapter 120](#)).

1610.05(8) Barrier Delineation

Refer to [1030.06](#) for delineation requirements.

1610.06 Beam Guardrail

1610.06(1) Beam Guardrail Systems

Beam guardrail systems are shown in the *Standard Plans*.

Strong post W-beam guardrail (Types 1 through 4, and 31) and three beam guardrail (Types 10 and 11) are semirigid barriers used predominantly on roadsides. They have limited application as median barrier. Installed incorrectly, strong post W-beam guardrail can cause vehicle snagging or spearing. This can be avoided by lapping the rail splices in the direction of traffic (as shown in the *Standard Plans*), by using crash-tested end treatments, and by blocking the rail away from the strong posts. However, avoid the use of blockouts that extend from the post to the rail element for a distance exceeding 16 inches. Placement of curb at guardrail installations also requires careful consideration.

Previously, WSDOT standard practice was to install W-beam guardrail at a rail height of 27 inches. However, there are newer designs that use a 31-inch rail height. One is the 31-inch-high WSDOT Type 31. The Type 31 system uses many of the same components as the WSDOT Type 1 system. However, the main differences are that the blockouts extend 12 inches from the posts, the rail height is 31 inches from the ground to the top of the rail, and the rail elements are spliced between posts.

The 31-inch-high system offers tolerance for future HMA overlays. The Type 31 system allows a 3-inch tolerance from 31 inches to 28 inches without adjustment of the rail element.

1610.06(2) W-Beam Barrier Selection and Placement

During the project development processes, consult with maintenance staff to help identify guardrail runs that may need to be upgraded.

- Use the 31-inch-high guardrail design for new runs. When guardrail is installed along existing shoulders with a width greater than 4 feet, the shoulder width may be reduced by 4 inches to accommodate the 12-inch blockout without processing a deviation.
- Existing runs with rail height at 27 inches are acceptable to leave in place and can be extended if the design height of 27 inches is maintained in the extended section. Where future overlays are anticipated, extend with Type 1 alternate or the 31-inch design.
- For existing runs below 26 inches, adjust or replace the rail to a height of 26 inches minimum to 28 inches maximum, or replace the run with the 31-inch-high guardrail design.
- Some 31-inch-high proprietary guardrail designs that do not incorporate the use of blockouts have been successfully crash-tested. The use of this type of system may be appropriate for some applications. Contact the HQ Design Office for further details.

Some designs for Type 31 applications are under development and will be added to the HQ Design Standards (Plan Sheet Library: www.wsdot.wa.gov/design/standards/plansheet) as soon as they are completed. Plans will be housed at this location until they are transitioned into the *Standard Plans*. **Note:** If a design is not available for the Type 31 guardrail system, a Type 1 guardrail design may be used.

1610.06(3) **Beam Guardrail Post Selection Criteria**

- WSDOT has experienced inconsistencies in the service life of wood guardrail posts. As a result, WSDOT conducted a life cycle analysis and has elected to discontinue the use of wood guardrail posts for new guardrail runs. Use steel posts for new beam guardrail runs.
- Existing runs of guardrail with wooden posts are acceptable to leave in place if in good condition and minimum height criteria can be maintained. (See [1610.06\(2\)](#) for additional guidance.)
- Posts in an existing wooden guardrail run may be replaced in kind.
- It is acceptable to extend existing wood post guardrail runs with either steel or wood posts and also with the associated approved wood or steel post terminals and anchors.
- When removing and resetting guardrail runs, consider using steel posts and reusing or replacing other components and hardware depending on condition.

1610.06(4) **Additional Guidance**

- Weak post W-beam guardrail (Type 20) and thrie beam guardrail (Type 21) are flexible barrier systems that can be used where there is adequate deflection distance (see the [Standard Plans](#)). These systems use weak steel posts. The primary purpose of these posts is to position the guardrail vertically, and they are designed to bend over when struck. These more flexible systems will likely result in less damage to the impacting vehicle. Since the weak posts will not result in snagging, blockouts are not necessary.
- Keep the slope of the area between the edge of the shoulder and the face of the guardrail 10H:1V or flatter. On fill slopes between 6H:1V and 10H:1V, avoid placing within 12 feet of the break point. Do not place beam guardrail on a fill slope steeper than 6H:1V. (See [Exhibit 1610-4](#) for additional guidance on beam guardrail slope placement.)
- On the high side of superelevated sections, place beam guardrail at the edge of shoulder prior to the slope break.
- For W-beam guardrail installed at or near the shoulder, 2 feet of shoulder widening behind the barrier is generally provided from the back of the post to the beginning of a fill slope (see [Exhibit 1610-11](#), Case 2). If the slope is 2H:1V or flatter, this distance can be measured from the face of the guardrail rather than the back of the post (see [Exhibit 1610-11](#), Case 1).
- On projects where no roadway widening is proposed and the minimum 2-foot shoulder widening behind the barrier is not practicable, long post installations are available as shown in [Exhibit 1610-11](#), Cases 3, 4, 5, and 6. When guardrail is to be installed in areas where the roadway is to be widened or along new alignments, the use of Cases 5 and 6 requires a design deviation.
- Rail washers on beam guardrail are not normally used. If rail washers are present, removal is not necessary except for posts 2 through 8 of an existing BCT installation. However, if the rail element is removed for any reason, do not reinstall rail washers. In areas where heavy snow accumulations are expected to cause the bolts to pull out, specify snowload post washers and rail washers in the contract documents. (Snowload post washers are used to help prevent the bolts from pulling through the posts, and snowload rail washers are used to help prevent the bolt head from pulling through the rail.) In other installations, it is normal to have the rail pull loose from the bolt head when impacted. Do not use rail washers within the limits of a guardrail terminal except at the end post where they are needed for anchorage of the rail.

- The use of curb in conjunction with beam guardrail is discouraged. If a curb is needed, the 3-inch-high curb is preferred. If necessary, the 4-inch-high extruded curb can be used behind the face of rail at any posted speed. The 6-inch-high extruded curb can be used at locations where the posted speed is 50 mph or below. When replacing extruded curb at locations where the posted speed is above 50 mph, use 3-inch-high or 4-inch-high curb. (See the [Standard Plans](#) for extruded curb designs.)
- **Note:** When used in conjunction with the 31-inch-high Type 31 W-beam guardrail, an acceptable option is to place up to a 6-inch-high extruded curb at a maximum 6-inch offset outside the face of the rail at any posted speed. Contact the WSDOT Design Office for more information.
- Beam guardrail is usually galvanized and has a silver color. It can also be provided in weathering steel that has a brown or rust color. Along Scenic Byways, Heritage Tour Routes, state highways through national forests, or other designated areas where aesthetic barrier is needed, consider using weathering steel guardrail, colored terminals (powder-coated galvanized steel), and colored steel posts (galvanized weathering steel or powder-coated galvanized steel) to minimize the barrier's visual impact (see [1610.05\(7\)](#)).
- In areas where weathering steel will be used and the steel post options cannot be used because of stakeholder constraints (for example, those listed in a "Corridor Management Plan"), the wood post option may be used with justification (Design Decision Memo).
- There are new methods under development that may change the options for providing colored guardrail to meet the aesthetic barrier. The HQ Design Office will circulate guidance on these new developments as they are adopted as WSDOT policy.

1610.06(5) Terminals and Anchors

A guardrail anchor is needed at the end of a run of guardrail to develop tensile strength throughout its length. In addition, when the end of the guardrail is subject to head-on impacts, a crash-tested guardrail terminal is needed (see the [Standard Plans](#)).

1610.06(5)(a) Buried Terminal (BT)

A buried terminal is designed to terminate the guardrail by burying the end in a backslope. The BT is the preferred terminal because it eliminates the exposed end of the guardrail.

The BT uses a Type 2 anchor to develop the tensile strength in the guardrail. The backslope needed to install a BT is to be 3H:1V or steeper and at least 4 feet in height above the roadway. The entire BT can be used within the length of need for backslopes of 1H:1V or steeper if the barrier remains at full height in relation to the roadway shoulder to the point where the barrier enters the backslope. For backslopes between 1H:1V and 3H:1V, design the length of need beginning at the point where the W-beam remains at full height in relation to the roadway shoulder—usually beginning at the point where the barrier crosses the ditch line. If the backslope is flatter than 1H:1V, provide a minimum 20-foot-wide by 75 foot-long distance behind the barrier and between the beginning length of need point at the terminal end to the mitigated object to be protected.

For new BT installations, use the Buried Terminal Type 2. **Note:** Previously, another BT option (the Buried Terminal Type 1) was an available choice. For existing situations, it is acceptable to leave this option in service as long as height requirements and other previous design criteria can still be met.

1. Buried Terminal Type 2

Flare the guardrail to the foreslope/backslope intersection using a flare rate that meets the criteria in [1610.05\(4\)](#). Provide a 4H:1V or flatter foreslope into the face of the guardrail and maintain the full guardrail height to the foreslope/backslope intersection in relation to a 10H:1V line extending from edge of shoulder breakpoint. (See the *Standard Plans* for details.)

1610.06(5)(b) Nonflared Terminal

If a BT terminal cannot be installed as described in [1610.06\(5\)\(a\)](#), consider a nonflared terminal (see [Exhibit 1610-12a](#)). For Type 31 guardrail systems, there are currently two acceptable sole source proprietary designs: the ET-31 and the SKT-SP-MGS. These systems use W-beam guardrail with a special end piece that fits over the end of the guardrail. Steel posts are used throughout the length of the terminal. When hit head on, the end piece is forced over the rail and either flattens or bends the rail and then forces it away from the impacting vehicle.

Both the SKT-SP-MGS and the ET-31 terminals include an anchor for developing the tensile strength of the guardrail. The length of need begins at the third post for both terminals. Both of these terminals are available in two designs, which are based on the posted speed of the highway. For highways with a posted speed of 45 mph or above, use the ET-31 (TL3) or the SKT-SP-MGS (TL3) terminal. For lower-speed highways (a posted speed of 40 mph or below), use the ET-31 (TL2) or SKT-SP-MGS (TL2).

While these terminals do not need to have an offset at the end, a flare is recommended so that the end piece does not protrude into the shoulder. These terminals may have a 2-foot offset to the first post. Four feet of widening is needed at the end posts to properly anchor the system. When widening includes an embankment, fill material will be necessary for optimum terminal performance. (See the *Standard Plans* for widening details.)

When the entire barrier run is located farther than 12 feet beyond the shoulder break point and the slopes are greater than 10H:1V and 6H:1V or flatter, additional embankment at the terminal is not needed.

No snowload rail washers are allowed within the limits of these terminals.

When a Beam Guardrail Type 1 nonflared terminal is needed, two sole source proprietary terminals, the ET-PLUS or the Sequential Kinking Terminal (SKT), may be used (see [Exhibit 1610-12b](#)). Both of these Type 1 barrier terminals are available in two designs based on the posted speed of the highway. The primary difference in these designs is the length of the terminal. For highways with a posted speed of 45 mph or above, use the 50-foot-long ET PLUS TL3 or the SKT 350 terminal. For lower-speed highways (a posted speed of 40 mph or below), use the 25 foot-long ET PLUS TL2 or SKT-TL2.

The FHWA has granted approval to use the above sole source nonflared proprietary terminals without justification.

Note: Approved shop drawings for terminals can be found by accessing the following website:
www.wsdot.wa.gov/design/policy/trafficbarriers.htm

1610.06(5)(c) Flared Terminal

WSDOT does not use a flared terminal system for the Type 31 system. However, if a flared terminal is needed for other applications, there are currently two acceptable sole source proprietary designs: the Slotted Rail Terminal (SRT) and the Flared Energy Absorbing Terminal (FLEAT). Both of these designs include an anchor for developing the tensile strength of the guardrail. The length of need begins at the third post for both flared terminals.

1. The SRT uses W-beam guardrail with slots cut into the corrugations and posts throughout the length of the terminal. The end of the SRT is offset from the tangent guardrail run by the use of a parabolic flare. When struck head on, the first two posts are designed to break away, and the parabolic flare gives the rail a natural tendency to buckle, minimizing the possibility of the guardrail end entering the vehicle. The buckling is facilitated by the slots in the rail. The remaining posts provide strength to the system for redirection and deceleration without snagging the vehicle. The SRT has a 4 foot offset of the first post.

The SRT terminal can be supplied with wood or steel posts. Match the type of SRT posts with those of the longitudinal barrier run to which the terminal will be connected.

2. The FLEAT uses W-beam guardrail with a special end piece that fits over the end of the guardrail and posts. The end of the FLEAT is offset from the tangent guardrail run by the use of a straight flare. When struck head on, the end piece is forced over the rail, bending the rail and forcing it away from the impacting vehicle.

Note: Approved shop drawings for terminals can be found by accessing the following website:
www.wsdot.wa.gov/design/policy/trafficbarriers.htm

The FLEAT is available in two designs based on the posted speed of the highway. For highways with a posted speed of 45 mph or above, use a FLEAT 350, which has a 4-foot offset at the first post. For lower-speed highways (a posted speed of 40 mph or below), use a FLEAT TL-2, which has a 1 foot-8-inch offset at the first post.

The FLEAT terminal can be supplied with wood or steel posts. Match the type of FLEAT posts with those of the longitudinal barrier run to which the terminal will be connected.

When a flared terminal is specified, it is critical that the embankment quantity also be specified so that the area around the terminal can be constructed as shown in the [Standard Plans](#).

When the entire barrier run is located greater than 12 feet beyond the shoulder break point and the slopes are greater than 10H:1V and 6H:1V or flatter, additional embankment at the terminal is not needed.

Snowload rail washers are not allowed within the limits of these terminals.

The FHWA has granted approval to use the SRT and the FLEAT sole source proprietary flared terminals without justification.

1610.06(5)(d) Terminal Evolution Considerations

Some currently approved terminals have been in service for a number of years. During this time, there have been minor design changes. However, these minor changes have not changed the devices' approval status. Previous designs for these terminals may remain in place. (For guidance on BCT terminals, see [1610.04\(1\)](#).)

Note: If questions arise concerning the current approval status of a device, contact the HQ Design Office for clarification when replacement is being considered.

1610.06(5)(e) Other Anchor Applications

Use the Type 10 anchor to develop the tensile strength of the guardrail on the end of Type 31 guardrail runs where a crash-tested terminal is not needed. The Type 1 or Type 4 anchor is used for older Beam Guardrail Type 1 where a crash-tested terminal is not needed. Use the Type 5 anchor with the Weak Post Intersection Design (see 1610.06(7)(b), Cases 12 and 13). Use the Type 7 anchor to develop tensile strength in the middle of a guardrail run when the guardrail curves and weak posts are used (see 1610.06(7)(b), Cases 9, 12, and 13).

The old Type 3 anchor was primarily used at bridge ends (see Exhibit 1610-5). This anchor consisted of a steel pipe mounted vertically in a concrete foundation. Bridge approach guardrail was then mounted on the steel pipe.

- On one-way highways, these anchors were usually positioned so that neither the anchor nor the bridge rail posed a snagging potential. When these cases are encountered, the anchor may remain in place if a stiffened transition section is provided at the connection to the post.
- On two-way highways, the anchor may present a snagging potential. In these cases, install a connection from the anchor to the bridge rail if the offset from the bridge rail to the face of the guardrail is 1 foot 6 inches or less. If the offset is greater than 1 foot 6 inches, remove the anchor and install a new transition and connection.

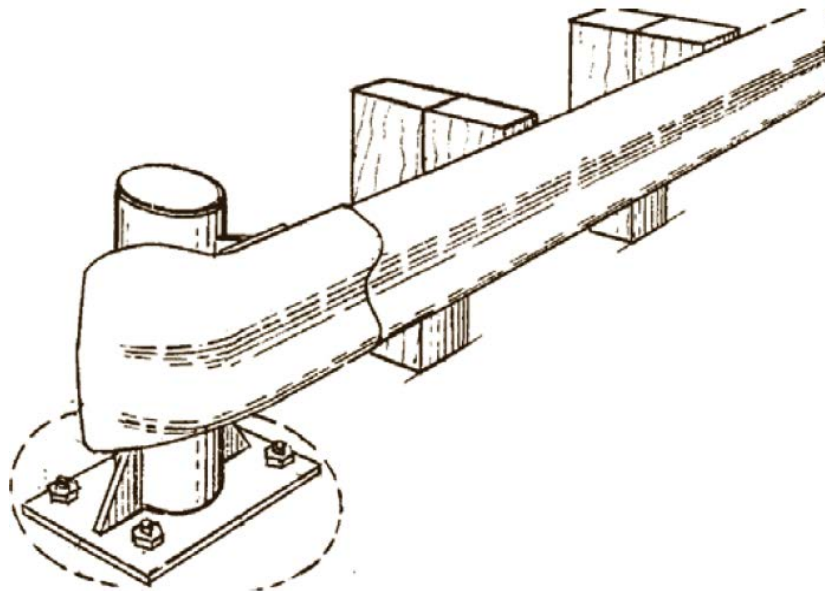

Old Type 3 Anchor
Exhibit 1610-5

Locations where crossroads and driveways cause gaps in the guardrail create situations for special consideration. Elimination of the need for the barrier is the preferred solution. Otherwise, a barrier flare might be needed to provide sight distance. If the slope is 2H:1V or flatter and there are no fixed features on or at the bottom of the slope, a terminal can be used to end the rail (see Chapters 1310 and 1340 for additional sight distance guidance). Place the anchor of this installation as close as possible to the road approach radius PC.

1610.06(6) Transitions and Connections

When there is an abrupt change from one barrier type to a more rigid barrier type, a vehicle hitting the more flexible barrier is likely to be caught in the deflected barrier pocket and directed into the more rigid barrier. This is commonly referred to as “pocketing.” A transition stiffens the more flexible barrier by decreasing the post spacing, increasing the post size, and using stiffer beam elements to eliminate the possibility of pocketing.

When connecting beam guardrail to a more rigid barrier or a structure, or when a rigid object is within the deflection distance of the barrier, use the transitions and connections that are shown in Exhibits 1610-6 and 1610-9 and detailed in the *Standard Plans*. The transition pay item includes the connection.

Condition	Connection
Unrestrained concrete barrier	A
Rigid, rigid anchored, untapered safety shape bridge rails or barriers ^[1]	B
Bridge rails with curbs 9 inches or less in width	B
Bridge rails with curbs between 9 and 18 inches wide	C
Vertical walls, <u>single slope</u> , or tapered safety shape barrier ^[1]	D
Note:	
[1] New <u>single slope and</u> safety shape bridge rails are designed with the toe of the barrier tapered so that it does not project past the face of the approach guardrail.	

Guardrail Connections

Exhibit 1610-6

1610.06(7) Guardrail Placement Cases

The *Standard Plans* contains placement cases that show beam guardrail elements needed for typical situations. For some applications, the *Standard Plans* provides options for both Type 1 and Type 31 guardrail for similar installations. For new installations, use the appropriate Type 31 placement option. Additional placement cases incorporate other combinations of barrier types.

1610.06(7)(a) Beam Guardrail Type 31 Placements (for new installations)

- **Case 1-31** is used where there is one-way traffic. It uses a crash-tested terminal on the approach end and a Type 10 anchor on the trailing end.
- **Case 2-31** is used where there is two-way traffic. A crash-tested terminal is used on both ends.
- **Case 3-31** is used at railroad signal supports on one-way or two-way roadways. A terminal is used on the approach end, but usually cannot be used on the trailing end because of its proximity to the railroad tracks. If there is a history of crossover accidents, consider additional protection such as an impact attenuator.
- **Case 4-31** is used where guardrail on the approach to a bridge is to be shifted laterally to connect with the bridge rail. A terminal is used on the approach end and a transition is needed at the bridge end. A curve in the guardrail is shown to shift it to the bridge rail. However, the length of the curve is not critical. The criterion is to provide a smooth curve that is not more abrupt than the allowable flare rate (see [Exhibit 1610-3](#)).

- **Case 5-31** is a typical bridge approach where a terminal and a transition are needed.
- **Case 6** is used on bridge approaches where opposing traffic is separated by a median that is 36 feet or wider. This case is designed so that the end of the guardrail will be outside the Design Clear Zone for the opposing traffic.
- **Case 10 (A-31, B-31, and C-31)** is used at roadside fixed features (such as bridge piers) when 3 or more feet are available from the face of the guardrail to the feature. The approach end is the same for one-way or two-way traffic. Case 10A-31 is used with two-way traffic; therefore, a terminal is needed on the trailing end. Case 10B-31 is used for one-way traffic when there is no need to extend guardrail past the bridge pier and a Type 10 anchor is used to end the guardrail. Case 10C-31 is used for one-way traffic when the guardrail will extend for a distance past the bridge pier.
- **Case 11 (A-31, B-31, and C-31)** is used at roadside fixed features (such as bridge piers) when the guardrail is to be placed within 3 feet of the feature. Since there is no room for deflection, the rail in front of the feature is to be considered a rigid system and a transition is needed. The trailing end cases are the same as described for Case 10.
- **Beam Guardrail Type 31 (12'6", 18'9", or 25' Span)** is used when it is necessary to omit one, two, or three posts. This application is typically used when guardrail is installed over drainage structures but may have other applications if adequate deflection distance is present. Three CRT posts are provided on each end of the omitted post(s).
- **Guardrail Placement Strong Post – Type 31** is the “Strong Post Intersection Design for Type 31 barrier” that provides a stiff barrier. This design is used at crossroads or road approaches where a barrier is needed and where the length of need cannot be achieved using standard components such as standard longitudinal barrier runs, transitions, and terminals.

Note: Some placement cases for use with Beam Guardrail Type 31 are currently under development. As plans become available, they will be housed in the HQ Design Standards (Plan Sheet Library) until they become Standard Plans (www.wsdot.wa.gov/design/standards/plansheet).

1610.06(7)(b) Additional Placement Cases (typically, for existing installations)

- **Case 1** is used where there is one-way traffic. It uses a crash-tested terminal on the approach end and a Type 4 anchor on the trailing end.
- **Case 2** is used where there is two-way traffic. A crash-tested terminal is used on both ends. When flared terminals are used on both ends, use a minimum of 25 feet of guardrail between the terminal limits when feasible.
- **Case 3** is used at railroad signal supports on one-way or two-way roadways. A terminal is used on the approach end, but usually cannot be used on the trailing end because of its proximity to the railroad tracks. If there is a history of crossover accidents, consider additional protection such as an impact attenuator.
- **Case 4** is used where guardrail on the approach to a bridge is to be shifted laterally to connect with the bridge rail. A terminal is used on the approach end and a transition is needed at the bridge end. A curve in the guardrail is shown to shift it to the bridge rail. However, the length of the curve is not critical. The criterion is to provide a smooth curve that is not more abrupt than the allowable flare rate (see [Exhibit 1610-3](#)).
- **Case 5** is a typical bridge approach where a terminal and a transition are needed.
- **Case 6** is used on bridge approaches where opposing traffic is separated by a that is 36 feet or wider. This case is designed so that the end of the guardrail will be outside the Design Clear Zone for the opposing traffic.

- **Cases 7 and 8** are used with beam guardrail median barrier when median fixed features such as bridge piers are encountered. A transition is needed on the approach end for each direction, and the flare rate is not to be more abrupt than the allowable flare rate (see [Exhibit 1610-3](#)).
- **Case 9 (A, B, and C)** is used on bridge approaches where opposing traffic is separated by a median less than 36 feet wide. This design, called a “Bull Nose Terminal,” treats both bridge ends and the opening between the bridges. The “nose” is designed to collapse when struck head on, and the ribbon strength of the rail brings the vehicle to a controlled stop. Type 7 anchors are installed on each side of the nose to develop the ribbon strength. Since an impacting vehicle might penetrate into the system, it is critical that no fixed feature be located within the first 65 feet of the system.
- **Case 10 (A, B, and C)** is used at roadside fixed features (such as bridge piers) when 3 or more feet are available from the face of the guardrail to the object. The approach end is the same for one-way or two-way traffic. Case 10A is used with two-way traffic; therefore, a terminal is needed on the trailing end. Case 10B is used for one-way traffic when there is no need to extend guardrail past the bridge pier and a Type 4 anchor is used to end the guardrail. Case 10C is used for one-way traffic when the guardrail will extend for a distance past the bridge pier.
- **Case 11 (A, B, and C)** is used at roadside fixed features (such as bridge piers) when the guardrail is to be placed within 3 feet of the object. Since there is no room for deflection, the rail in front of the feature is to be considered a rigid system and a transition is needed. The trailing end cases are the same as described for Case 10.
- **Cases 12 and 13** are called “Weak Post Intersection Designs.” They are used where an intersection design needs a gap in the guardrail or there is not adequate space for a bridge approach installation that includes a transition, a terminal, or both. These placements are designed to collapse when hit at the nose, and the ribbon strength of the rail brings the vehicle to a stop. A Type 7 anchor is used to develop the ribbon strength. These designs include a Type 5 transition for connection with bridge rail and a Type 5 anchor at the other end of the rail. The Type 5 anchor is not a breakaway anchor and therefore can typically be used only in situations where a crash-tested terminal is not needed; for example, where slow-moving vehicles are anticipated, such as some side roads and driveways.

Since an impacting vehicle might penetrate into the system, it is critical that no fixed feature be located within the clear area shown in the [Standard Plans](#). The 25 feet of barrier length beyond the PC along the side road are critical for the operation of this system.

These designs were developed for intersections that are approximately perpendicular. Evaluate installation on skewed intersections on a case-by-case basis. Use the Case 22 placement if it is not feasible to install this design according to the [Standard Plans](#).

- **Case 14** shows the approach rail layout for a Service Level 1 bridge rail system. Type 20 guardrail is used on the approach and no transition is needed between the Type 20 guardrail and the Service Level 1 bridge rail since they are both weak post systems. A Type 6 transition is used when connecting the Type 20 to a strong post guardrail or a terminal.
- **Case 15** is used to carry guardrail across a box culvert where there is insufficient depth to install standard posts for more than 17 feet 8 inches. This design uses steel posts anchored to the box culvert to support the rail. Newer designs—Cases 19, 20, and 21—have replaced this design for shorter spans.
- **Cases 16 and 17** are similar to Cases 1 and 2, except that they flare the rail and terminal as far from the road as possible and reduce the length of need.

- **Case 18** is used on the trailing end of bridge rail on a one-way roadway. No transition is needed.
- **Case 19 (A and B)** is used where it is not possible to install a post at the 6 foot 3-inch spacing. This design omits one post (resulting in a span of 11 feet 6 inches, which is consistent with a post spacing of 12 feet 6 inches) and uses nested W-beam to stiffen the rail. The cases differ by the location of the splice. No cutting of the rail or offsetting of the splices is needed or desirable.
- **Case 20** is similar to Cases 19A and 19B, except that it allows for two posts to be omitted, which results in a span consistent with post spacing of 18 feet 9 inches.
- **Case 21** has a similar intent as Cases 19A, 19B, and 20 in that it allows for the omission of posts to span an obstruction. This design uses CRT posts with additional post blocks for three posts before and after the omitted posts. The design allows for three posts to be omitted, which results in a span consistent with a post spacing of 25 feet.
- **Case 22** is the “Strong Post Intersection Design” that provides a stiff barrier. This design is to be used as a last resort at crossroads or road approaches where a barrier is needed and there isn’t a clear area behind the nose or minimum distances for a “Weak Post Intersection Design” (see Cases 12 and 13).

Note: Some placement cases for use with Beam Guardrail Type 31 are currently under development. As plans become available, they will be housed in the HQ Design Standards (Plan Sheet Library) until they become Standard Plans ([see www.wsdot.wa.gov/design/standards/plansheet](http://www.wsdot.wa.gov/design/standards/plansheet)).

1610.07 Cable Barrier

Cable barrier is a flexible barrier system that can be used on a roadside or as a median barrier. It is used primarily in medians and is preferred for many installations due in part to its high benefit-to-cost ratio. Some of the advantages of cable barrier are:

- It provides effective vehicle containment and redirection while imposing the lowest deceleration forces on the vehicle’s occupant(s).
- It may reduce the severity of collisions, which is of significant importance on high-speed facilities.
- After it is struck, it has a tendency not to redirect vehicles back into traffic, which can help reduce the frequency of secondary collisions.
- It can often be placed on existing facilities without the delay of extended environmental permitting and the expense of complex highway reconstruction that might be needed for other barrier system choices.
- It has advantages in heavy snowfall areas because it has minimal potential to create snowdrifts.
- In crucial wildlife habitats, it can aid in some types of animal movements.
- It does not present a visual barrier, which may make it desirable on Scenic Byways (see [1610.05](#)).
- The effort (time and materials) needed to maintain and repair cable barrier systems is much less than the effort needed for a W-beam system.

Deflection is a consideration in narrower median areas and in many urban and other limited-width situations. Use of cable barrier in these situations may not be possible or may require special designs.

For new installations, use four-cable high-tension cable barrier systems, which are available from several manufacturers.

1610.07(1) High-Tension Cable Barrier Placement

For typical median applications with slopes between 10H:1V and 6H:1V, the following apply when using single runs of cable barrier (see [Exhibit 1610-13a](#)):

- Cable barrier may be installed in the centerline of the ditch.
- Cable barrier can be offset from the ditch centerline no more than 1 foot (left or right).
- Avoid installing cable barrier within a 1-foot to 8-foot offset from the ditch centerline.
- When locating cable barrier between an 8-foot offset from the ditch centerline and the slope breakpoint, place the cable barrier as far from the edge of traveled way as practicable. Provide a minimum placement distance of 8 feet to the edge of traveled way to allow vehicles to use this area for refuge (see [Exhibit 1610-13a](#)).
- For median shoulder applications, place the cable barrier as far from the edge of traveled way as practicable. Maintain a minimum of 8 feet of usable shoulder width between the edge of traveled way and the face of the cable barrier system (see [Exhibit 1610-13a](#)).

Note: [Exhibit 1610-13a](#) shows typical median placement criteria for single runs of cable barrier. Additional placement cases are shown in the WSDOT *Standard Plans*. For non-typical installations, such as double runs of cable barrier or median ditch cross sections that differ significantly from those shown, contact the HQ Design Office for guidance.

- In some situations with cable barrier installations in medians, it is advantageous to terminate a run on one side of the median and begin an adjacent run on the opposite side. In this type of application, it is important to provide adequate cable barrier over-lap distance between the two runs. For placement guidance, see [Exhibit 1610-13c](#).

Narrow medians provide little space for maintenance crews to repair or reposition the barrier. Wherever site conditions permit, provide at least 14 feet of clearance from the adjacent lane edge to the cable barrier.

For typical non-median shoulder applications (see [Exhibit 1610-13b](#)), the following apply:

- Place the cable barrier as far from the edge of traveled way as practicable.
- For shoulder widths less than 8 feet, see [1610.05\(2\)](#) for further guidance.
- Install cable between slope breakpoints as shown in [Exhibit 1610-13b](#).
- Install cable barrier on slopes that are 6H:1V or flatter.
- Cable barrier can be installed up to 1 foot in front of slope breakpoints as steep as 2H:1V.

Note: There are approved high-tension cable barrier systems that can be placed on slopes as steep as 4H:1V. The use of these systems requires special placement considerations. Contact the HQ Design Office for guidance when selecting these systems.

1610.07(2) High-Tension Cable Barrier Deflection Distances

Depending on the system and post spacing, deflection distances for high-tension barrier systems may range from approximately 6 to 12 feet. Specify the maximum allowable deflection distance in the contract documents. (See Exhibits [1610-13a](#) and [13b](#) for placement details.)

Note: There are new high-tension cable barrier systems under development that may change selection and placement criteria. The HQ Design Office will circulate guidance on these new developments as they are adopted as WSDOT policy.

1610.07(3) High-Tension Cable Barrier Termination

- It is possible to terminate high-tension cable barrier systems by connecting directly to beam guardrail runs that are rigidly anchored (such as transitions to bridge rails) and also to a separate anchorage system. Designers should review field conditions, check local maintenance personnel needs, and then specify the required connection option in the contract documents. If a separate anchorage system is used, refer to [Exhibit 1610-13c](#) for placement guidance.
- When cable barrier is to be connected to a more rigid barrier, a transition section is typically needed. Contact the HQ Design Office for further details.

1610.07(4) High-Tension Cable Barrier Height Criteria

Select a high-tension four-cable barrier system with a height to the center of the top cable of not less than 35 inches and a height to the center of the bottom cable not greater than 19 inches.

1610.07(5) High-Tension Cable Barrier Curb Placement

Avoid the placement of curb in conjunction with high-tension cable barrier systems. Currently, there are no known acceptable cable barrier systems that have been successfully crash tested with this feature present.

Note: There are high-tension cable barrier systems under development that may change selection and placement criteria. The HQ Design Office will circulate guidance on these new developments as they are adopted as WSDOT policy.

1610.08 Concrete Barrier

General Considerations:

- Concrete barriers are rigid, rigid anchored, or unrestrained rigid systems. Commonly used in medians, they are also used as shoulder barriers. These systems are stiffer than beam guardrail or cable barrier, and impacts with these barriers tend to be more severe.
- Light standards mounted on top of concrete median barrier must not have breakaway features. (See the concrete barrier light standard section in the [Standard Plans](#).)
- When concrete barrier is considered for use in areas where drainage and environmental issues (such as stormwater, wildlife, or endangered species) might be adversely impacted, contact the HQ Hydraulics Office and the appropriate environmental offices for guidance.

1610.08(1) Concrete Barrier Shapes

Concrete barriers use a single-slope or safety shape (New Jersey or F-Shape) to redirect vehicles while minimizing vehicle vaulting, rolling, and snagging. A comparison of these barrier shapes is shown in [Exhibit 1610-7](#).

The single-slope barrier face is the recommended option for embedded rigid concrete barrier applications.

Note: There are new precast concrete barrier systems under development that may change future selection and placement criteria. The HQ Design Office will circulate guidance on these new developments as they are adopted as WSDOT policy.

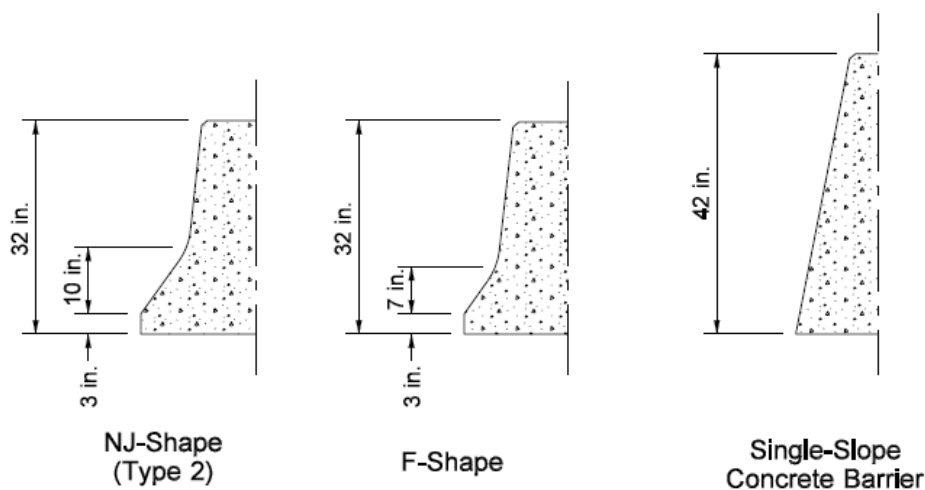

Concrete Barrier Shapes

Exhibit 1610-7

When the single-slope or F-Shape face is used on structures, and precast barrier is selected for use on the approaches, a cast-in-place transition section is needed so that no vertical edges of the barrier are exposed to oncoming traffic. For details on bridge rail designs, see the [Bridge Design Manual](#).

For aesthetic reasons, avoid changes in the shape of the barrier face within a project or corridor.

The New Jersey shape and F-shape barriers are commonly referred to as “safety shapes.” The New Jersey shape and F-shape have an initial overall height of 32 inches. This height includes provision for up to a 3-inch future pavement overlay that can reduce the barrier height to 29 inches minimum.

1610.08(1)(a) New Jersey Shape Barrier

The New Jersey shape face is primarily used on precast concrete barrier.

Concrete barrier Type 2 (see the [Standard Plans](#)) is a precast barrier that has the New Jersey shape on two sides and can be used for both median and shoulder installations.

The cost of precast Type 2 barrier is significantly less than the cost of the cast-in-place barriers. Therefore, consider the length of the barrier run and the deflection needs to determine whether transitioning to precast Type 2 barrier is desirable. If precast Type 2 barrier is used for the majority of a project, use the New Jersey face for small sections that need cast-in-place barrier, such as for a light standard section.

Concrete barrier Type 4 is also a precast, single-faced New Jersey shape barrier. These units are not freestanding and are to be placed against a rigid structure or anchored to the pavement. If Type 4 barriers are used back to back, consider filling any gap between them to prevent tipping.

Concrete barrier Type 5 is a precast barrier that has a single New Jersey face and is intended for use at bridge ends where the flat side is highly visible. Both Type 2 and Type 5 designs are freestanding, unanchored units connected with steel pins through wire rope loops. For permanent installation, this barrier is placed on a paved surface and a 2-foot-wide paved surface is provided beyond the barrier for its displacement during impact (see [Chapter 1230](#)).

Precast barrier can be anchored where a more rigid barrier is needed. (Anchoring methods are shown in the [Standard Plans](#).) The Type 1 and Type 2 anchors are for temporary installations on a rigid pavement. Type 3 anchors can be used in temporary or permanent installations on an asphalt pavement. Consult the HQ Bridge and Structures Office for details when anchoring permanent precast concrete barrier to a rigid pavement.

Precast barrier used on the approach to bridge rail is to be connected to the bridge rail by installing wire rope loops embedded 1 foot 3 inches into the bridge rail with epoxy resin.

Place unrestrained (unanchored) precast concrete barrier on foundation slopes of 5% or flatter. In difficult situations, a maximum slope of 8% may be used. Keep the slope of the area between the edge of the shoulder and the face of the traffic barrier as flat as possible. The maximum slope is 10H:1V (10%).

1610.08(1)(b) Single-Slope Barrier

The single-slope concrete barrier can be cast in place, slipformed, or precast. The most common construction technique for this barrier has been slipforming, but some precast single-slope barrier has been installed. The primary benefit of using precast single-slope barrier is that it can be used as temporary barrier during construction and then reset into a permanent location. In temporary applications, the single-slope barrier may also offer the added benefits of reducing headlight glare and providing reduced deflection characteristics over some other barrier types.

Single-slope barrier is considered a rigid system regardless of the construction method used. For new installations, the minimum height of the barrier above the roadway is 2 feet 10 inches, which allows a 2-inch tolerance for future overlays. The minimum total height of the barrier section is 3 feet 6 inches, with a minimum of 3 inches embedded in the roadway wearing surface. This allows for use of the 3-foot-6-inch barrier between roadways with grade separations of up to 5 inches. A grade separation of up to 10 inches is allowed when using a 4-foot-6-inch barrier section, as shown in the [Standard Plans](#). The barrier is to have a depth of embedment equal to or greater than the grade separation. Contact the HQ Bridge and Structures Office for grade separations greater than 10 inches.

1610.08(1)(c) Low-Profile Barrier

Low-profile barrier designs are available for median applications where the posted speed is 45 mph or below. These barriers are normally used in urban areas. They are typically 18 to 20 inches high and offer sight distance benefits. For barrier designs, terminals, and further details, contact the HQ Design Office.

1610.08(2) High-Performance Concrete Barrier

High-Performance Concrete Barrier (HP Barrier) is a rigid barrier with a minimum height of 42 inches above the roadway surface. This barrier is designed to function more effectively during heavy-vehicle collisions. This taller barrier may also offer the added benefits of reducing headlight glare and reducing noise in surrounding environments. HP Barrier is generally considered single-slope barrier. (See the *Standard Plans* for barrier details.) For additional available shapes, contact the HQ Design Office.

For new/reconstruction, use HP Barrier in freeway medians of 22 feet or less. Also, use HP Barrier on Interstate or freeway routes where accident history suggests a need or where roadway geometrics increase the possibility of larger trucks hitting the barrier at a high angle (for example, on-ramps for freeway-to-freeway connections with sharp curvature in the alignment).

Consider the use of HP Barrier at other locations such as nonfreeway narrow medians, near highly sensitive environmental areas, near densely populated areas, over or near mass transit facilities, or on vertically divided highways.

1610.08(3) Concrete Barrier Terminals

Whenever possible, bury the end of the concrete barrier in the backslope. The backslope needed to bury the end is to be 3H:1V or steeper and at least 4 feet in height above the roadway. Flare the concrete barrier into the backslope using a flare rate that meets the criteria in 1610.05(4). Provide a 10H:1V or flatter foreslope into the face of the barrier and maintain the full barrier height to the foreslope/backslope intersection. This might create the need to fill ditches and install culverts in front of the barrier face.

The 7-foot-long precast concrete terminal end section for concrete barrier Type 2 and the 10- to 12-foot single-slope barrier terminal may be used:

- Outside the Design Clear Zone.
- On the trailing end of the barrier when it is outside the Design Clear Zone for opposing traffic.
- On the trailing end of one-way traffic.
- Where the posted speed is 25 mph or below.

Another available end treatment for Type 2 barriers is a precast or cast-in-place tapered terminal section with a minimum length of 48 feet and a maximum length of 80 feet. It is used infrequently for special applications and is designed to be used for posted speeds of 35 mph or below. For details, contact the HQ Design Office or refer to the Plan Sheet Library: www.wsdot.wa.gov/design/standards/plansheet/

When the “Barrier Terminals and Transitions” column of a Design Matrix applies to a project, existing sloped-down concrete terminals that are within the Design Clear Zone are to be replaced when they do not meet the above criteria.

When the end of a concrete barrier cannot be buried in a backslope or terminated as described above, terminate the barrier using a guardrail terminal and transition or an impact attenuator (see Chapter 1620).

1610.08(4) Assessing Impacts to Wildlife

The placement of concrete barriers in locations where wildlife frequently cross the highway can influence traffic safety and wildlife mortality. When wildlife encounter physical barriers that are difficult to cross, they often travel parallel to those barriers. With traffic barriers, this means that they often remain on the highway for a longer period, increasing the risk of wildlife/vehicle collisions or vehicle/vehicle collisions as motorists attempt avoidance.

Traffic-related wildlife mortality may play a role in the decline of some species listed under the Endangered Species Act. To address public safety and wildlife concerns, see Exhibit 1610-8 to assess whether concrete barrier placement needs to have an evaluation by the HQ Environmental Services Office to determine its effect on wildlife. Conduct this evaluation early in the project development process to allow adequate time for discussion of options.

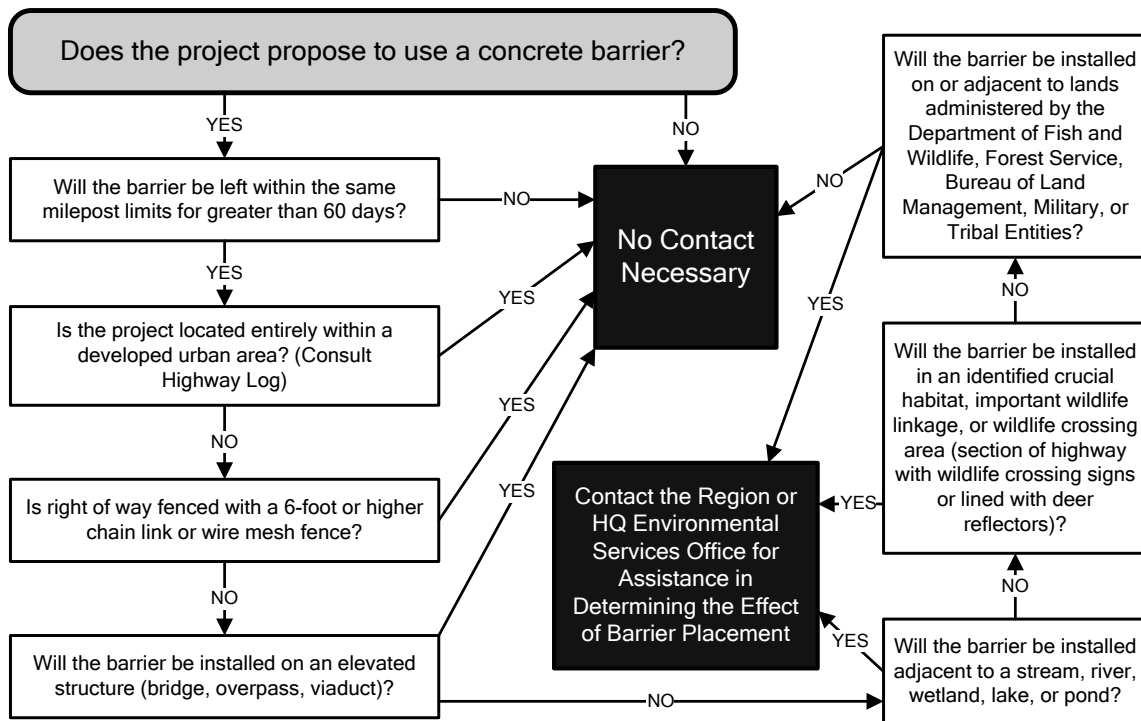

Concrete Barrier Placement Guidance: Assessing Impacts to Wildlife
Exhibit 1610-8

1610.08(5) Assessing Impacts to Stormwater and Wetlands

In locations where medians or roadsides are used for drainage, the retention of stormwater or the existence of wetlands can influence the choice and use of barrier systems. For example, the placement of concrete barrier and beam guardrail in many of these cases may create the need for additional impervious material, which can result in complete retrofit and reconstruction of the existing systems. When water is drained, stored, or treated, and where wetlands exist, the ability to provide alternative facilities that replace the functions of the existing ones may be nonexistent or prohibitively expensive to provide elsewhere.

To address public safety, stormwater, and wetland concerns, assess whether concrete barrier or beam guardrail placement will cause the need for an evaluation by the HQ Environmental Services Office. Conduct this evaluation early in the project development process to allow adequate time for discussion of options.

1610.09 Special-Use Barriers

The following barriers may be used on designated Scenic Byway and Heritage Tour routes if funding can be arranged (see [1610.05](#) and [Chapter 120](#)).

1610.09(1) *Steel-Backed Timber Guardrail*

Steel-backed timber guardrails consist of a timber rail with a steel plate attached to the back to increase its tensile strength. There are several variations of this system that have passed crash tests. The nonproprietary systems use a beam with a rectangular cross section that is supported by either wood or steel posts. A proprietary (patented) system called the Ironwood Guardrail is also available. This system uses a beam with a round cross section and is supported by steel posts with a wood covering to give the appearance of an all-wood system from the roadway.

The Ironwood Guardrail can be allowed as an alternative to the nonproprietary system. However, specifying this system exclusively needs approval by an Assistant State Design Engineer of a public interest finding for the use of a sole source proprietary item.

The most desirable method of terminating the steel-backed timber guardrail is to bury the end in a backslope, as described in [1610.06\(5\)](#). When this type of terminal is not possible, use of the barrier is limited to highways with a posted speed of 45 mph or below. On these lower-speed highways, the barriers can be flared away from the traveled way and terminated in a berm outside the Design Clear Zone.

For details on these systems, contact the HQ Design Office.

1610.09(2) *Stone Guardwalls*

Stone guardwalls function like rigid concrete barriers but have the appearance of natural stone. These walls can be constructed of stone masonry over a reinforced concrete core wall or of simulated stone concrete. These types of barriers are designed to have a limited projection of the stones to help aid in the redirection characteristics of the barrier. The most desirable method of terminating this barrier is to bury the end in a backslope, as described in [1610.08\(3\)](#). When this type of terminal is not possible, use of the barrier is limited to highways with a posted speed of 45 mph or below. On these lower-speed highways, the barrier can be flared away from the traveled way and terminated in a berm outside the Design Clear Zone.

For details on these systems, contact the HQ Design Office.

1610.10 Bridge Traffic Barriers

Bridge traffic barriers redirect errant vehicles and help to keep them from going over the side of the structure. (See the [Bridge Design Manual](#) for information regarding bridge barrier on new bridges and replacement bridge barrier on existing bridges.)

For new bridge rail installations, use a 2-foot-10-inch-high single-slope or a 2-foot-8-inch-high safety shape (F Shape) bridge barrier. A transition is available to connect the New Jersey shape (Type 2 concrete barrier) and the F-Shape bridge barrier. (See the [Standard Plans](#) for further details.)

Use taller 3-foot-6-inch single-slope or safety shape bridge barriers on Interstate or freeway routes where accident history suggests a need or where taller barrier is required on approaching roadways with narrow medians, as defined in [1610.08\(2\)](#). Also, consider taller 3-foot-6-inch barrier when geometrics increase the possibility of larger trucks hitting the barrier at a high angle (such as on-ramps for freeway-to-freeway connections with sharp curvature in the alignment).

For further guidance on bridges where high volumes of pedestrian traffic are anticipated, see Chapters [720](#), [1510](#), [1515](#), and [1520](#).

Approach barriers, transitions, and connections are usually needed on all four corners of bridges carrying two-way traffic and on both corners of the approach end for one-way traffic. (See [1610.06\(6\)](#) for guidance on transitions.)

If the bridge barrier system does not meet the criteria for strength and geometrics, modifications to improve its redirection characteristics and its strength may be needed. The modifications can be made using one of the retrofit methods described in [1610.10\(1\)](#) and [1610.10\(2\)](#).

1610.10(1) Concrete Safety Shape

Retrofitting with a new concrete bridge barrier is costly and needs to have justification when no widening is proposed. Consult the HQ Bridge and Structures Office for design details and to determine whether the existing bridge deck and other superstructure elements are of sufficient strength to accommodate this bridge barrier system.

1610.10(2) Thrie Beam Retrofit

Retrofitting with thrie beam is an economical way to improve the strength and redirection performance of bridge barriers. The thrie beam can be mounted to steel posts or the existing bridge barrier, depending on the structural adequacy of the bridge deck, the existing bridge barrier type, the width of curb (if any), and the curb-to-curb roadway width carried across the structure.

The HQ Bridge and Structures Office is responsible for the design of thrie beam bridge barrier. [Exhibit 1610-14](#) shows typical retrofit criteria. Contact the HQ Bridge and Structures Office for assistance with thrie beam retrofit design.

Consider the Service Level 1 (SL-1) system on bridges with wooden decks and for bridges with concrete decks that do not have the needed strength to accommodate the thrie beam system. Contact the HQ Bridge and Structures Office for information needed for the design of the SL-1 system.

A sidewalk reduction of up to 6 inches as a result of a thrie beam retrofit can be documented as a design exception.

The funding source for retrofit of existing bridge rail is dependent on the length of the structure. Bridge rail retrofit, for bridges less than 250 feet in length, or a total bridge rail length of 500 feet, is funded by the project ([Guardrail Preservation or Improvement](#)). For longer bridges, the retrofit will be included in the I-2 Bridge Rail upgrades program. Contact the HQ Program Development Office to determine whether funding is available.

1610.11 Other Barriers

1610.11(1) Dragnet

The Dragnet Vehicle Arresting Barrier consists of chain link or fiber net that is attached to energy absorbing units. When a vehicle hits the system, the Dragnet brings the vehicle to a controlled stop with limited damage. Possible uses for this device include the following:

- Reversible lane entrances and exits
- Railroad crossings
- Truck escape ramps (instead of arrester beds—see [Chapter 1270](#))
- T-intersections
- Work zones
- Swing span bridges

For permanent installations, this system can be installed between towers that lower the unit into position when needed and lift it out of the way when it is no longer needed. For work zone applications, it is critical to provide deflection space for stopping the vehicle between the system and the work zone. For additional information on the Dragnet, contact the HQ Design Office.

1610.12 Documentation

Refer to [Chapter 300](#) for design documentation requirements.

Connecting W-Beam Guardrail to: Transitions and Connections		Transition Type*	Connection	
Bridge Rail	New Installation	20, 21	D	
	Existing Concrete	Concrete Parapet > 20 inches	20, 21, 4 ^[4]	Exhibit 1610-6
		Concrete Parapet < 20 inches	2, 4 ^[4]	Exhibit 1610-6
		Existing W-Beam Transition	2 ^{[1][5]} , 4 ^[4]	[1]
	Thrie Beam at Face of Curb ^[3]	Approach End	23	n/a
		Trailing End (two-way traffic only)	23	n/a
	Thrie Beam at Bridge Rail (curb exposed) ^[3]	Approach End	22	n/a
		Trailing End (two-way traffic only)	22	n/a
	Weak Post Intersection Design (see 1610.06(7)(b), Cases 12 & 13)		5	Exhibit 1610-6
	Concrete Barrier	Rigid & Rigid Anchored	21	Exhibit 1610-6
Unrestrained		2, 4 ^[4]	A	
Weak Post Barrier Systems (Type 20 and 21)		6	n/a	
Rigid Structures such as Bridge Piers	New Installation (see Cases 11–31)	21	n/a	
	Existing W-Beam Transition	[2]	n/a	
Connecting Thrie Beam Guardrail to:		Transition Type*	Connection	
Bridge Rail or Concrete Barrier	New Installation (example: used with thrie beam bull nose)	1B	Exhibit 1610-6	

*Consult Section C of the *Standard Plans* for details on transition types.

Notes:

- [1] If work creates the need for reconstruction or resetting of the transition, upgrade as shown above. Raising the guardrail is not considered reconstruction. If the transition is not being reconstructed, the existing connection may remain in place. When Type 3 anchors are encountered, see 1610.06(5)(e) for guidance.
- [2] For new/reconstruction, use Case 11 (thrie beam). For existing Case 11 with W-beam, add a second W-beam rail element.
- [3] For Service Level 1 bridge rail, see 1610.06(7)(b), Case 14.
- [4] Use on highways with speeds 45 mph or below.
- [5] If existing transition has the needed guardrail height—three 10" x 10" (nominal) posts and three 6" x 8" (nominal) posts spaced 3'-1.5" apart—it is acceptable to nest existing single W-beam element transitions.

Transitions and Connections
Exhibit 1610-9

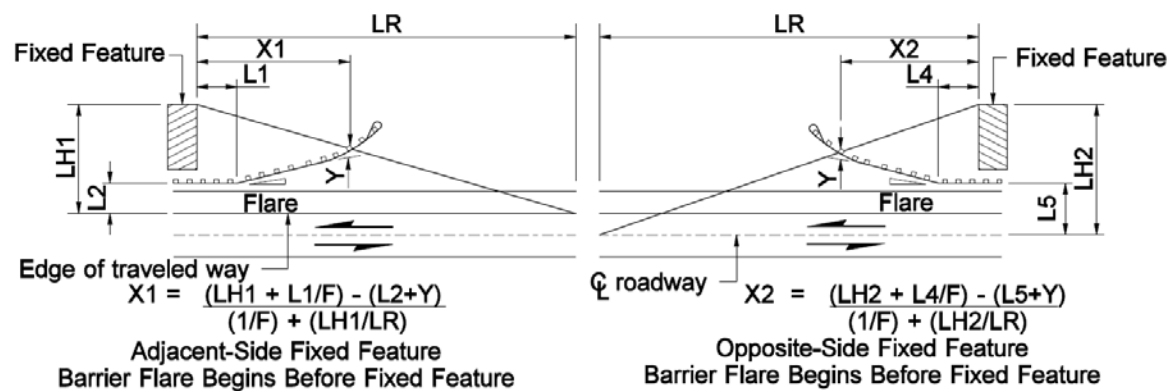
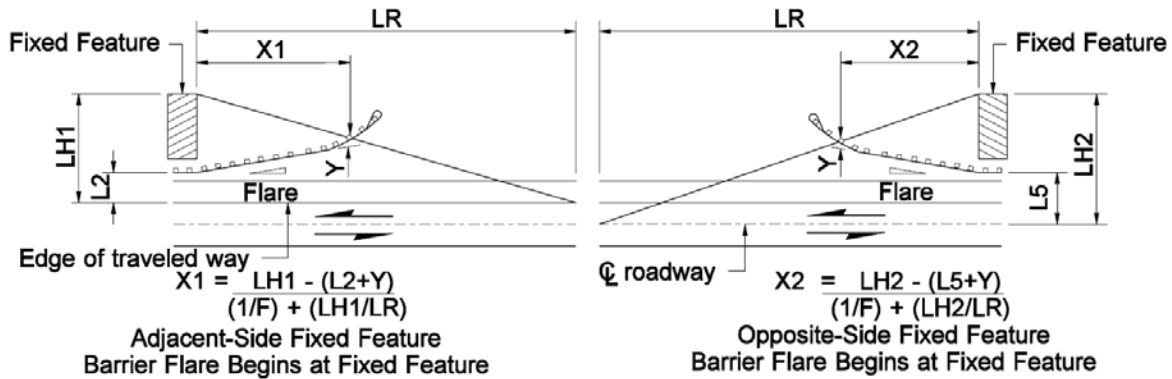
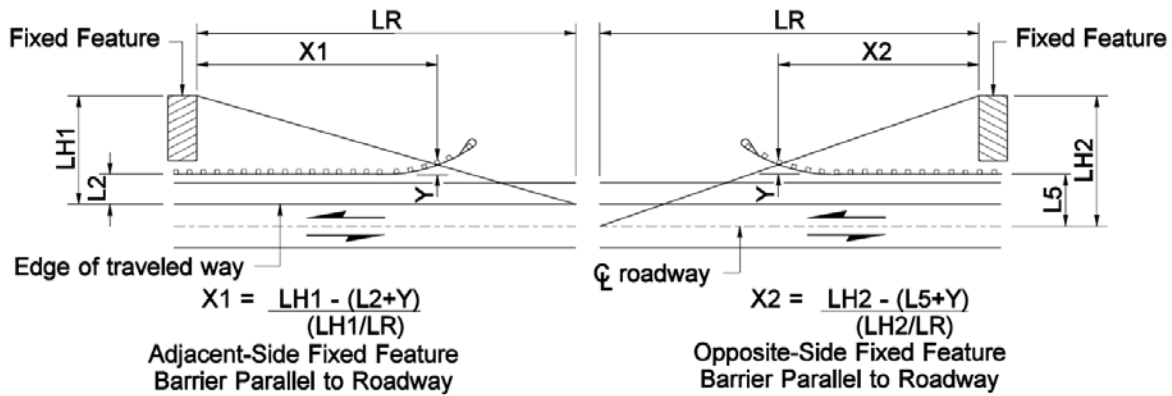

Note:

For supporting length of need equation factors, see [Exhibit 1610-10b](#).

Barrier Length of Need on Tangent Sections

Exhibit 1610-10a

Posted Speed (mph)	Design Parameters						
	ADT				Barrier Type		
	Over 10,000	5,000 to 10,000	1,000 to 4,999	Under 1,000	Rigid & Rigid Anchored Barrier	Rigid Unrestrained Barrier	Semirigid Barrier
	LR (ft)	LR (ft)	LR (ft)	LR (ft)	F	F	F
70	<u>360</u>	<u>330</u>	<u>290</u>	<u>250</u>	20	18	15
<u>65</u>	<u>330</u>	<u>290</u>	<u>250</u>	<u>225</u>	<u>20</u>	<u>18</u>	<u>15</u>
60	<u>300</u>	<u>250</u>	<u>210</u>	<u>200</u>	18	16	14
55	<u>265</u>	<u>220</u>	<u>185</u>	<u>175</u>	16	14	12
50	<u>230</u>	<u>190</u>	<u>160</u>	<u>150</u>	14	12	11
45	<u>195</u>	<u>160</u>	<u>135</u>	<u>125</u>	12	11	10
40	<u>160</u>	<u>130</u>	<u>110</u>	<u>100</u>	11	10	9
35	<u>135</u>	<u>110</u>	<u>95</u>	<u>85</u>	11	10	9
30	<u>110</u>	<u>90</u>	<u>80</u>	<u>70</u>	11	10	9
25	<u>110</u>	<u>90</u>	<u>80</u>	<u>70</u>	11	10	9

- L1 = Length of barrier parallel to roadway from adjacent-side fixed feature to beginning of barrier flare. This is used if a portion of the barrier cannot be flared (such as a bridge rail and the transition).
- L2 = Distance from adjacent edge of traveled way to portion of barrier parallel to roadway.
- L4 = Length of barrier parallel to roadway from opposite-side fixed feature to beginning of barrier flare.
- L5 = Distance from centerline of roadway to portion of barrier parallel to roadway. **Note:** If the fixed feature is outside the Design Clear Zone when measured from the centerline, it may only be necessary to provide a crash-tested end treatment for the barrier.
- LH1 = Distance from outside edge of traveled way to back side of adjacent-side fixed feature. Note: If a fixed feature extends past the Design Clear Zone, the Design Clear Zone can be used as LH1.
- LH2 = Distance from centerline of roadway to back side of opposite-side fixed feature. **Note:** If a fixed feature extends past the Design Clear Zone, the Design Clear Zone can be used as LH2.
- LR = Runout length, measured parallel to roadway.
- X1 = Length of need for barrier to shield an adjacent-side fixed feature.
- X2 = Length of need for barrier to shield an opposite-side fixed feature.
- F = Flare rate value.
- Y = Offset distance needed at the beginning of the length of need.

Different end treatments need different offsets:

- For the SRT 350 and FLEAT 350, use Y = 1.8 feet.
- For evaluating existing BCTs, use Y = 1.8 feet.
- For the FLEAT TL-2, use Y = 0.8 feet.
- No offset is needed for the nonflared terminals or impact attenuator systems. Use Y = 0.

Barrier Length of Need
Exhibit 1610-10b

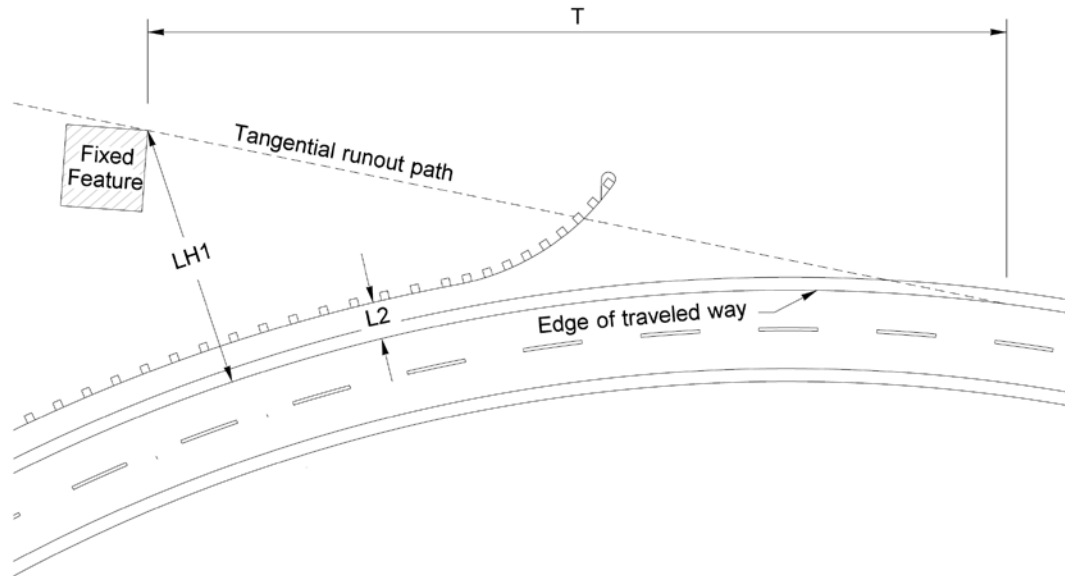

Notes:

- This is a graphical method for determining the length of need for barrier on the outside of a curve.
- On a scale drawing, draw a tangent from the curve to the back of the fixed feature. Compare T to LR from [Exhibit 1610-10b](#) and use the shorter value.
- If using LR, follow Exhibits [1610-10a](#) and [10b](#).
- If using T, draw the intersecting barrier run to scale and measure the length of need.

Barrier Length of Need on Curves
Exhibit 1610-10c

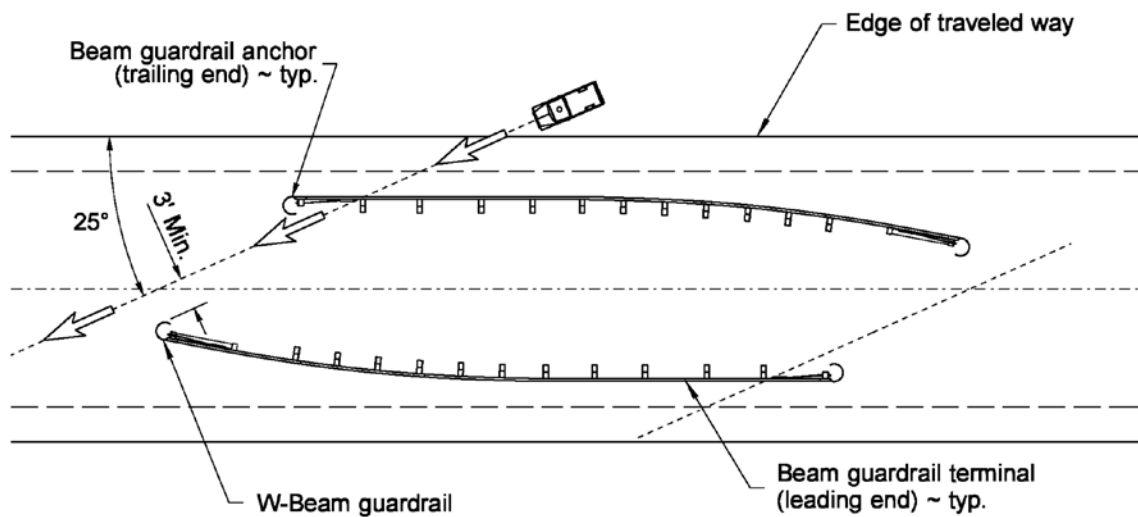

W-Beam Guardrail Trailing End Placement for Divided Highways
Exhibit 1610-10d

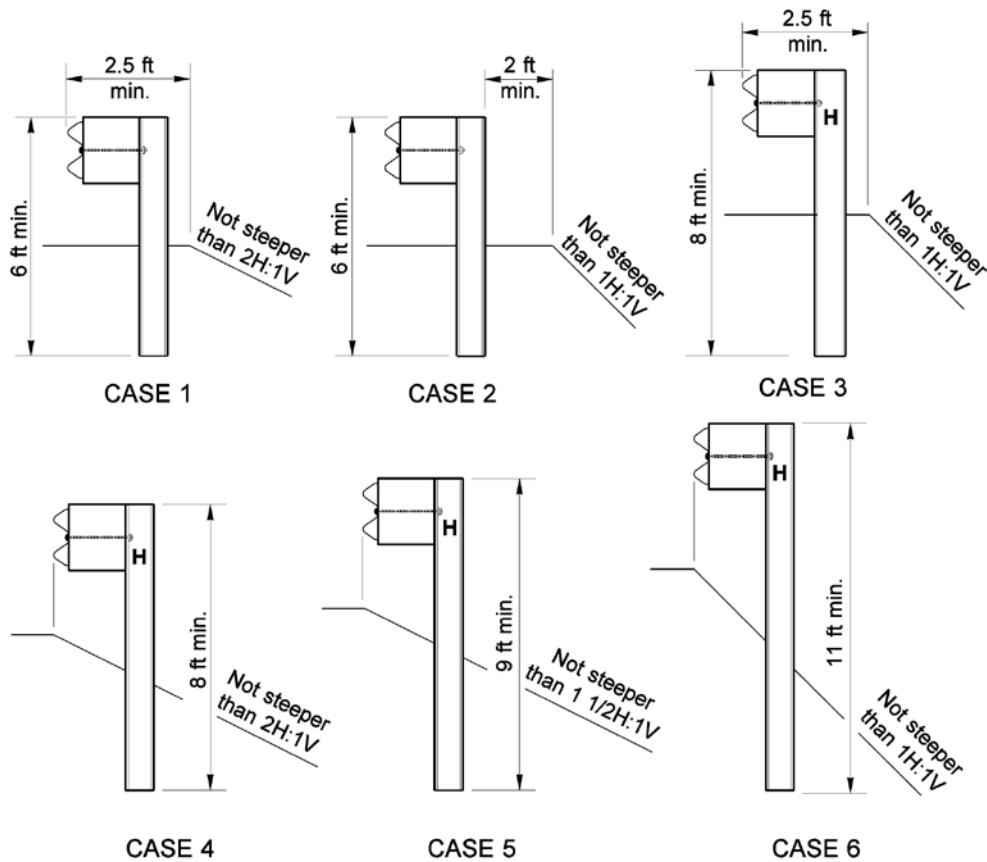

Type 31 Shown

Notes:

- Use Cases 1 and 3 when there is a 2.5-foot or greater shoulder widening from face of guardrail to the breakpoint.
- Use Case 2 when there is a 4.0-foot or greater shoulder widening from the face of the guardrail to the breakpoint.
- Use Cases 4, 5, and 6 when there is less than a 2.5-foot shoulder widening from face of guardrail to the breakpoint.

Beam Guardrail Post Installation
Exhibit 1610-11

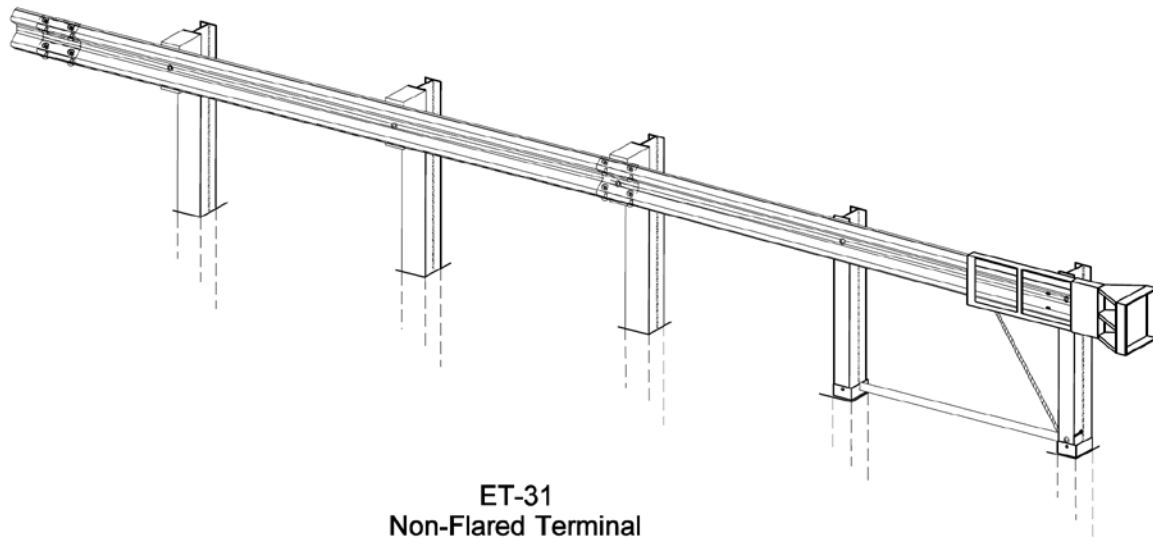
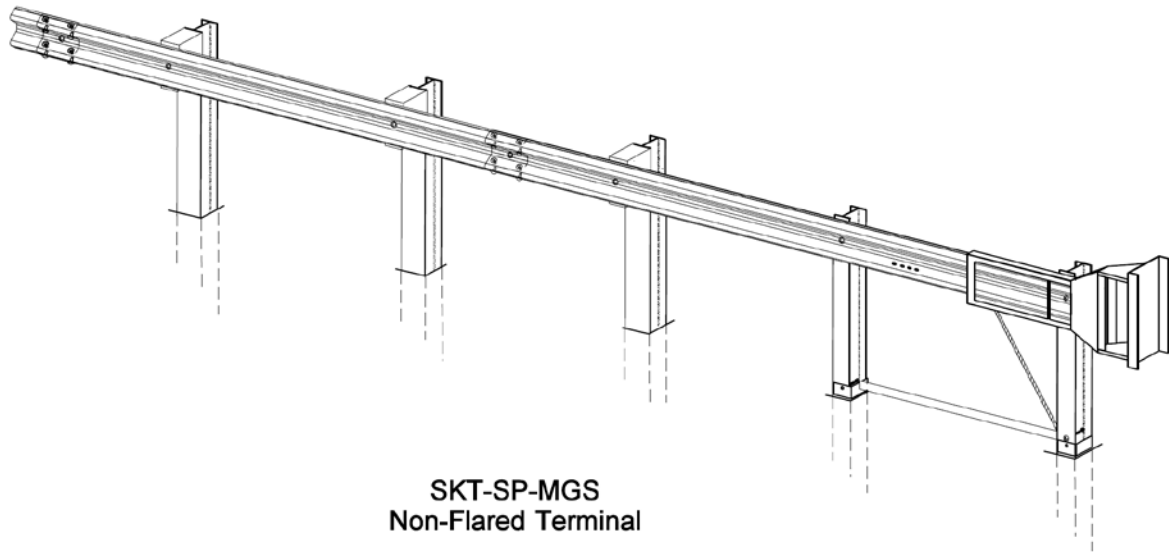

Beam Guardrail Terminals
Exhibit 1610-12a

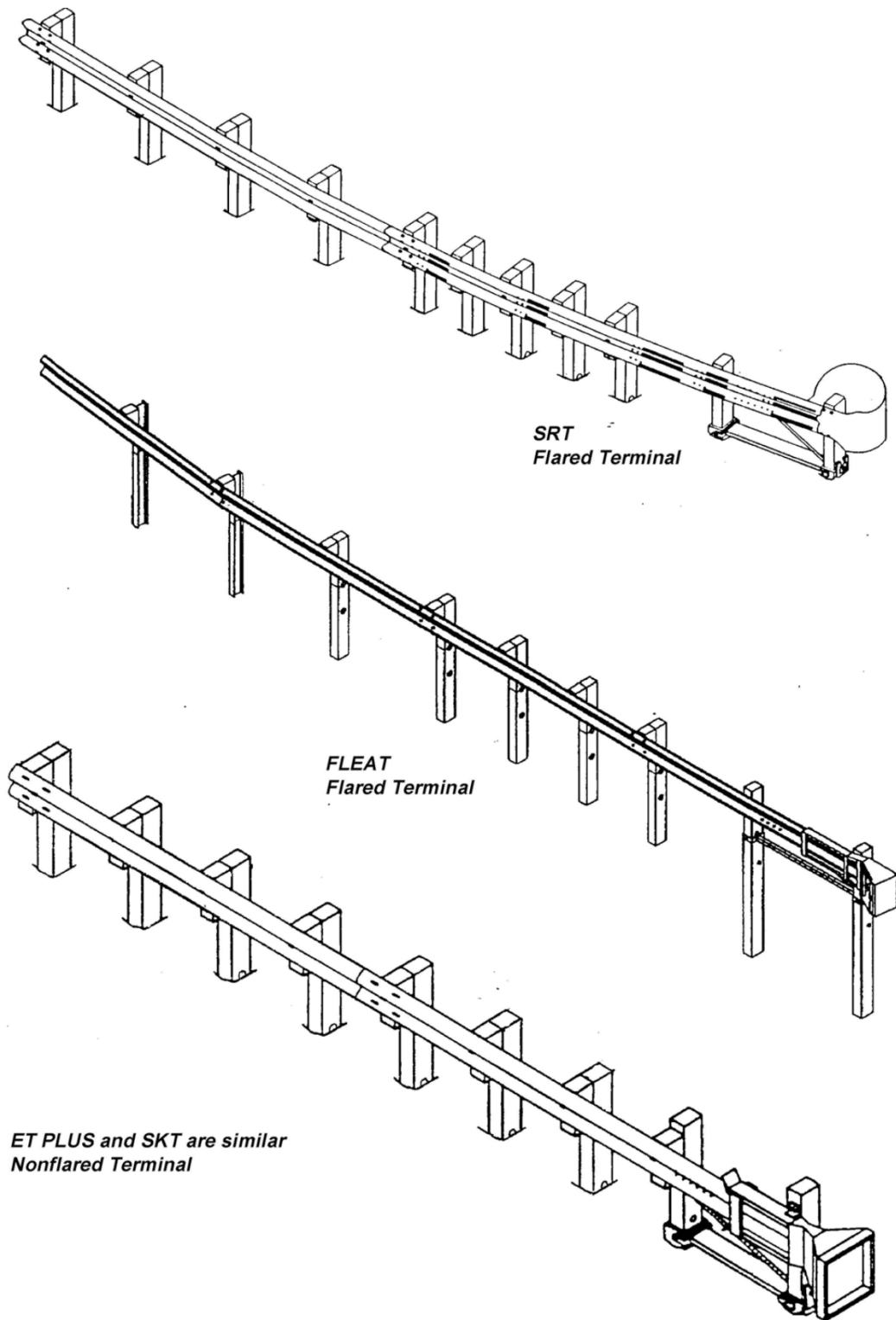

Beam Guardrail Terminals
Exhibit 1610-12b

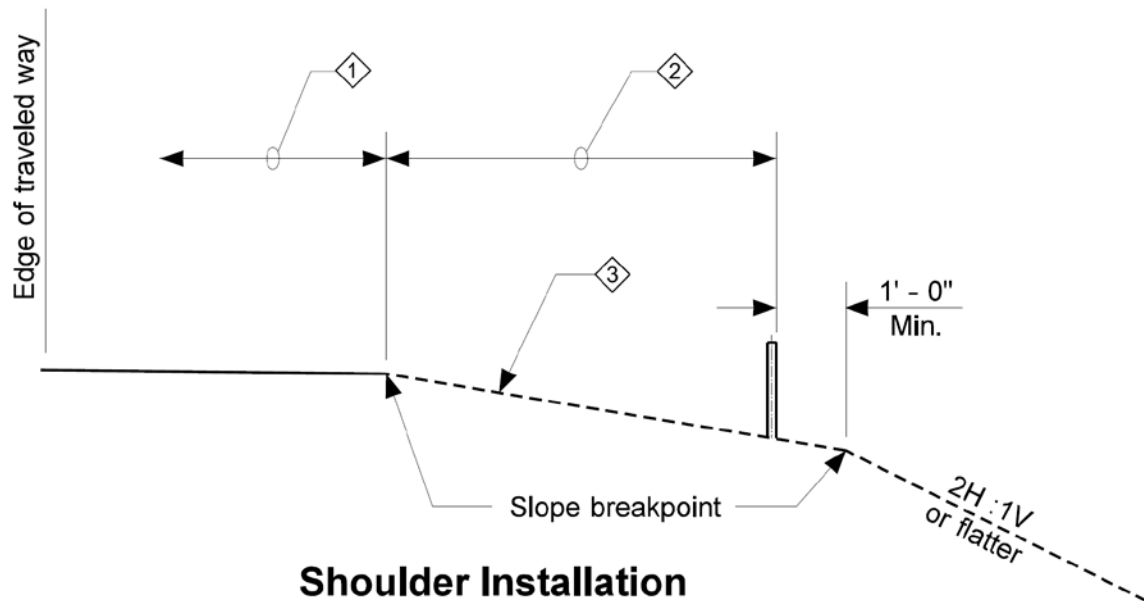

Shoulder Installation

Notes:

- ① For shoulder widths less than 8 feet, see [1610.05\(2\)](#) for further guidance.
- ② Slope Installation: Install cable barrier relative to the slope breakpoints within the limits shown.
- ③ Applies to slopes that are 6H:1V or flatter.

Cable Barrier Locations on Shoulder Slopes
Exhibit 1610-13b

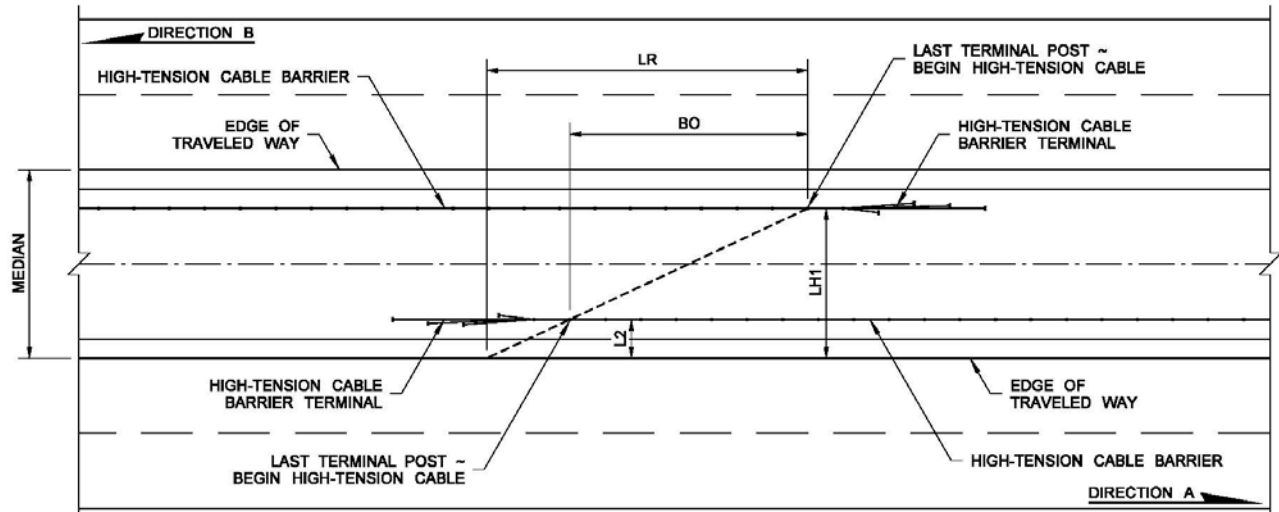

Cable Barrier Median Overlap

$$BO = \frac{LH1 - L2}{LH1/LR} \quad (\text{Direction A shown})$$

Note:

Calculate barrier overlap (BO) from both directions of travel. Use the greatest value of BO obtained.

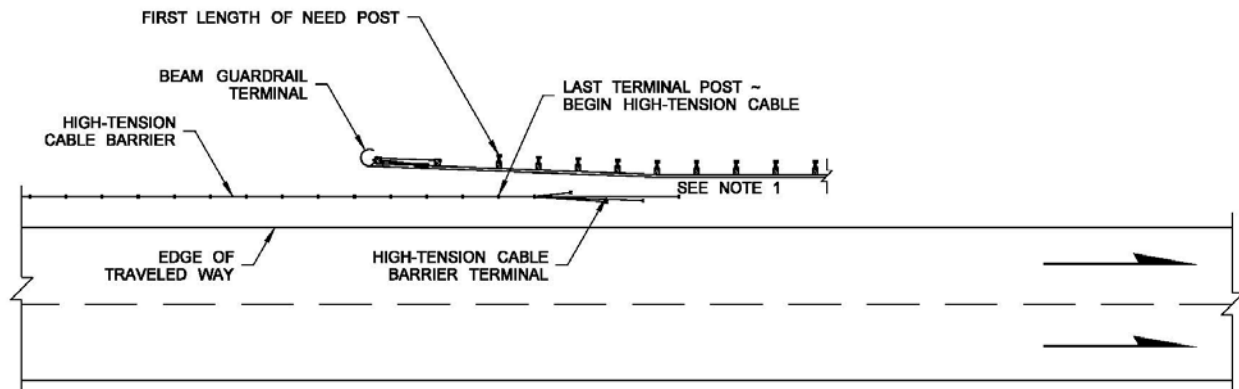

Cable Barrier Overlap With Beam Guardrails

Notes:

- [1] The beam guardrail may need to be extended and flared to maintain adequate barrier overlap and shoulder width.
- [2] Typical applications may be at bridge transitions or where high-tension cable and beam guardrail systems end or begin.
- [3] For supporting length of need equation factors, see [Exhibit 1610-10b](#).

Cable Barrier Placement for Divided Highways
Exhibit 1610-13c

Curb Width	Bridge Width	Concrete Bridge Deck		Wood Bridge Deck or Low-Strength Concrete Deck
		Concrete Bridge Rail (existing)	Steel or Wood Post Bridge Rail (existing)	
<18 inches		Thrie beam mounted to existing bridge rail ^[2] and blocked out to the face of curb. Height = 32 inches	Thrie beam mounted to steel posts ^[2] at the face of curb. Height = 32 inches	<ul style="list-style-type: none"> • Service Level 1 Bridge Rail^[2] • Height = 32 inches • Curb or wheel guard needs to be removed
>18 inches	> 28 ft (curb to curb)	Thrie beam mounted to steel posts ^[2] at the face of curb. ^[1] Height = 32 inches		
>18 inches	< 28 ft (curb to curb)	Thrie beam mounted to existing bridge rail. ^[2] Height = 35 inches	Thrie beam mounted to steel posts ^[2] in line with existing rail. Height = 35 inches	

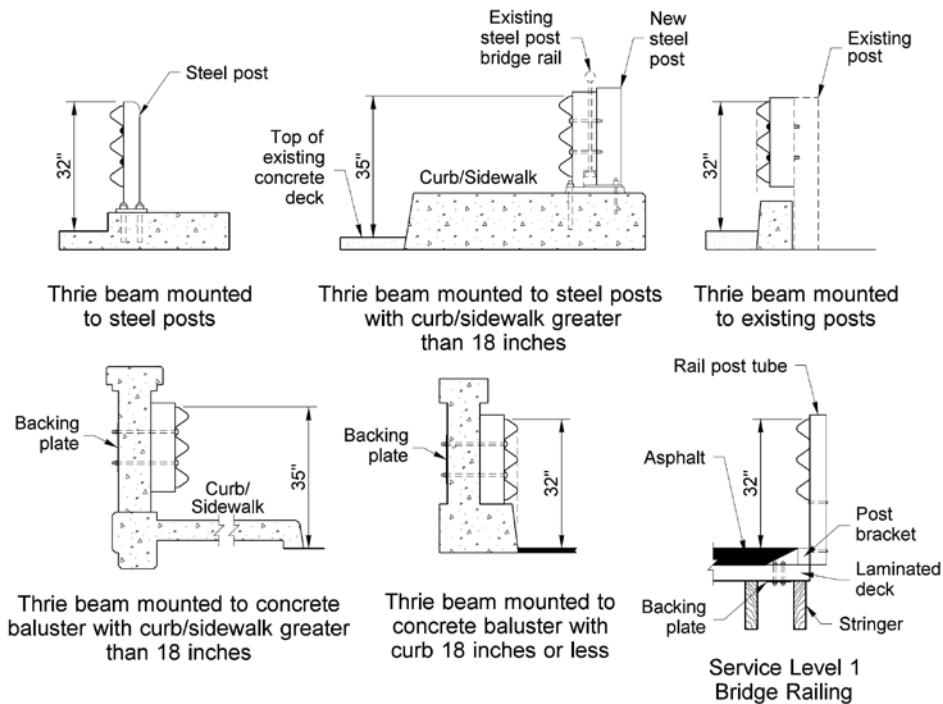

Notes:

- [1] To maximize available curb/sidewalk width for pedestrian use, thrie beam may be mounted to the bridge rail at a height of 35 inches.
- [2] Contact the HQ Bridge and Structures Office for design details on bridge rail retrofit projects.

Thrie Beam Rail Retrofit Criteria
Exhibit 1610-14