

NEW HAMPSHIRE DEPARTMENT OF TRANSPORTATION



BUREAU OF BRIDGE DESIGN



DESCRIPTION: SUBSTRUCTURE DETAILS -
TYPICAL GRAVITY WALL SECTION

DATE REVISED:
7/31/2023

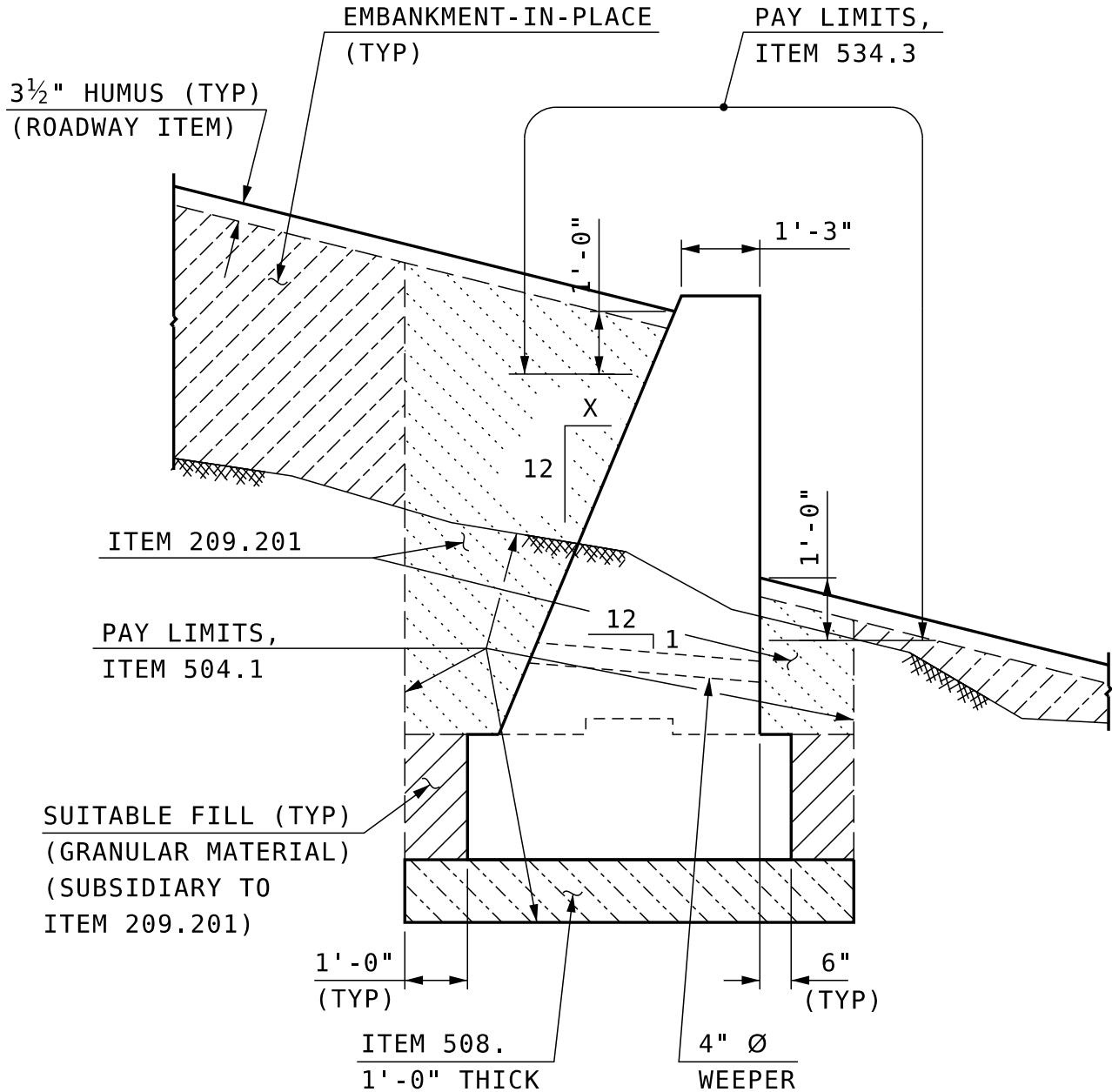

GRAVITY RETAINING WALL

MODIFY TO
FIT PROJECT

NEW HAMPSHIRE DEPARTMENT OF TRANSPORTATION



BUREAU OF BRIDGE DESIGN



DESCRIPTION:

MSE WALL -
TYPICAL SECTION

DATE REVISED:

7/31/2023

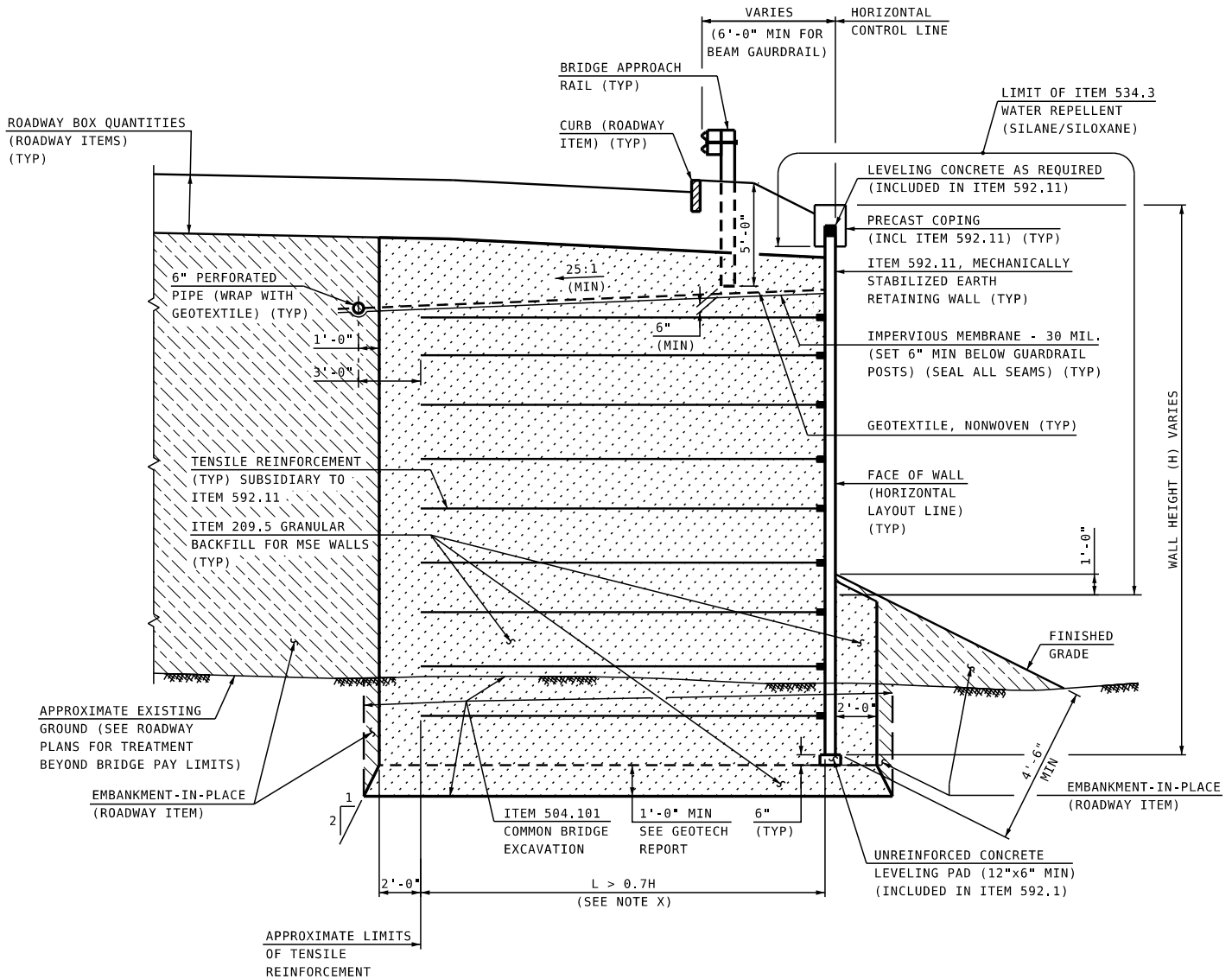

TYPICAL MSE WALL SECTION

(NOTE: FOUNDATION SHALL BE SHOWN AS RECOMMENDED BY GEOTECHNICAL ENGINEER)

MODIFY TO
FIT PROJECT

NEW HAMPSHIRE DEPARTMENT OF TRANSPORTATION



BUREAU OF BRIDGE DESIGN



DESCRIPTION:

MSE WALL -
CAST-IN-PLACE COPING DETAIL

DATE REVISED:

7/31/2023

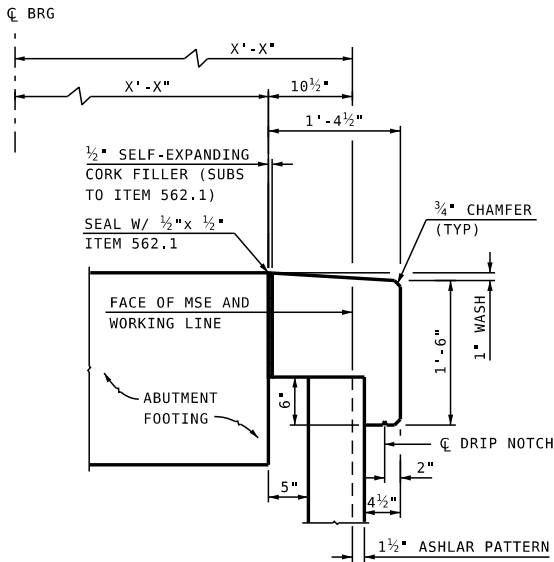

MASONRY

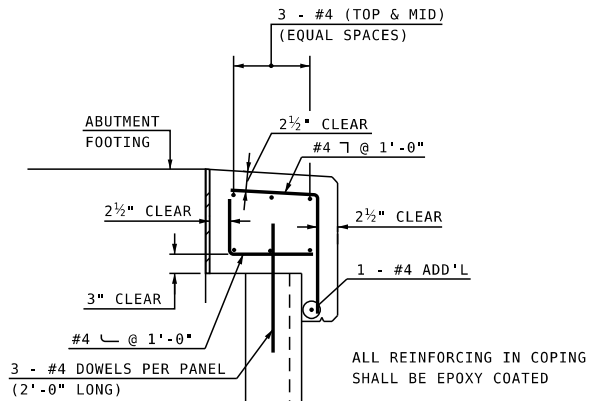

REINFORCEMENT

CAST IN PLACE COPING DETAIL

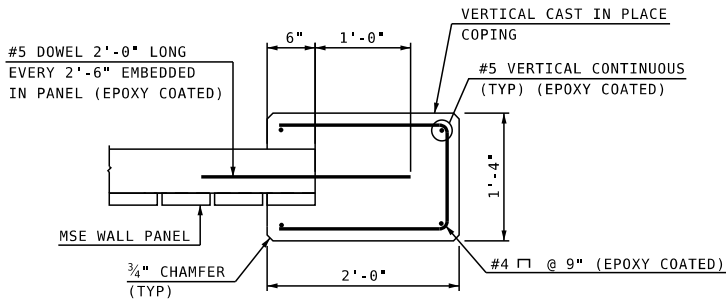

**SECTION THRU VERTICAL
CAST IN PLACE COPING**

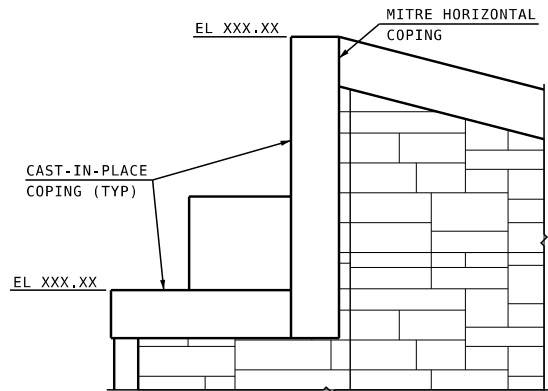

**ELEVATION VIEW VERTICAL
CAST IN PLACE COPING**

**MODIFY TO
FIT PROJECT**

NEW HAMPSHIRE DEPARTMENT OF TRANSPORTATION



BUREAU OF BRIDGE DESIGN



DESCRIPTION:

MSE WALL -
PRECAST COPING DETAIL

DATE REVISED:

7/31/2023

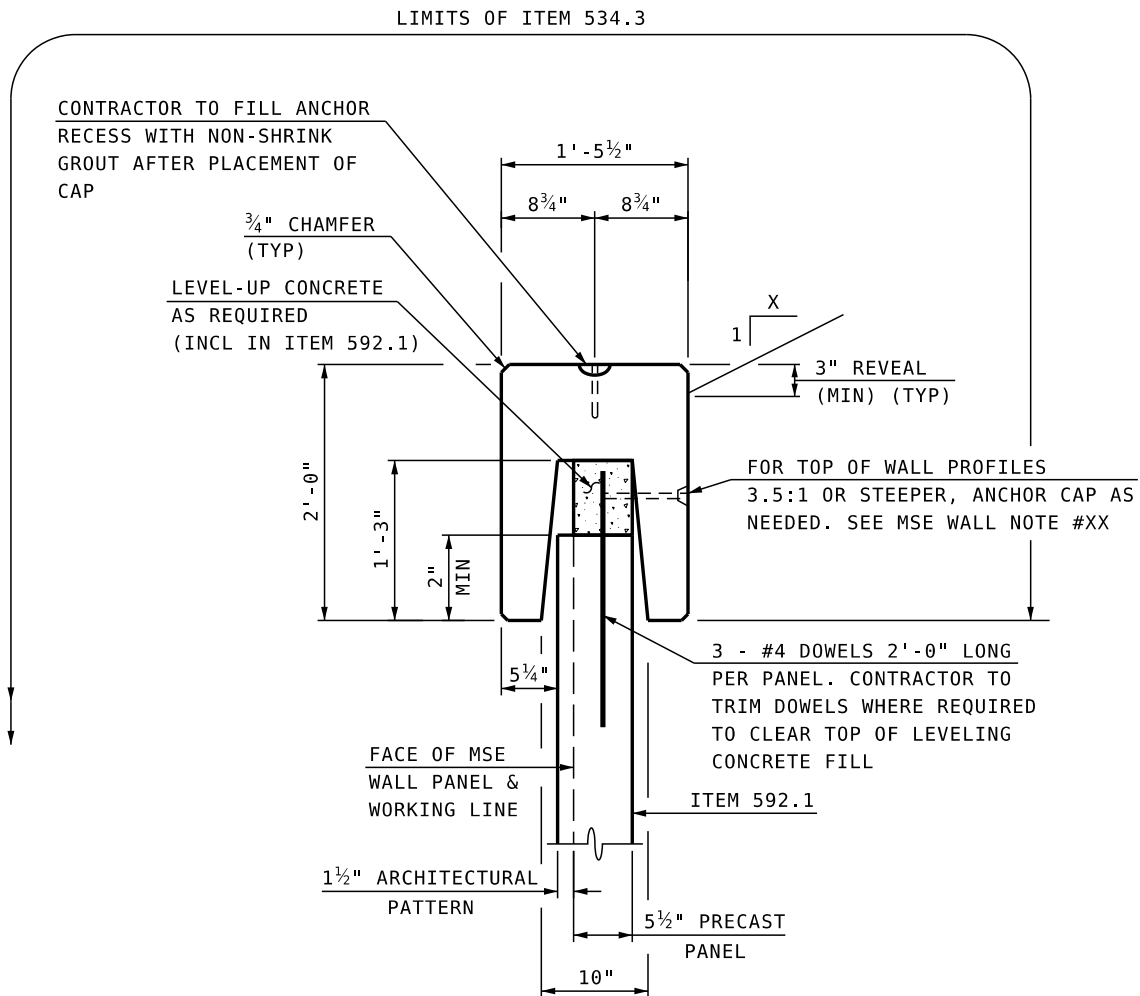

PRECAST CONCRETE COPING DETAIL

MODIFY TO
FIT PROJECT

NEW HAMPSHIRE DEPARTMENT OF TRANSPORTATION



BUREAU OF BRIDGE DESIGN



DESCRIPTION:

MSE WALL -
MOMENT SLAB DETAIL

DATE REVISED:

7/31/2023

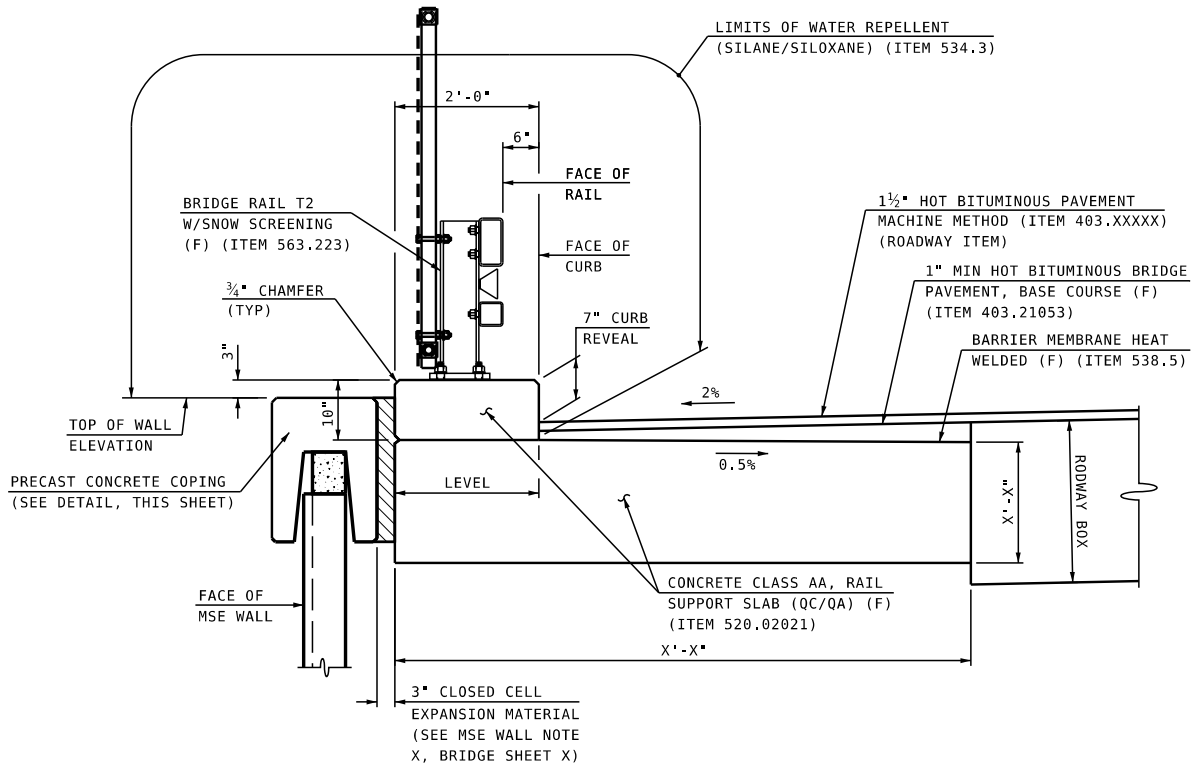

RAIL SUPPORT SLAB DETAIL

MODIFY TO
FIT PROJECT

NEW HAMPSHIRE DEPARTMENT OF TRANSPORTATION



BUREAU OF BRIDGE DESIGN



DESCRIPTION: **SUBSTRUCTURE DETAILS -
SHEET PILE WALL W/ ARCHITECTURAL TREATMENT**

DATE REVISED:
7/31/2023

**MODIFY TO
FIT PROJECT**

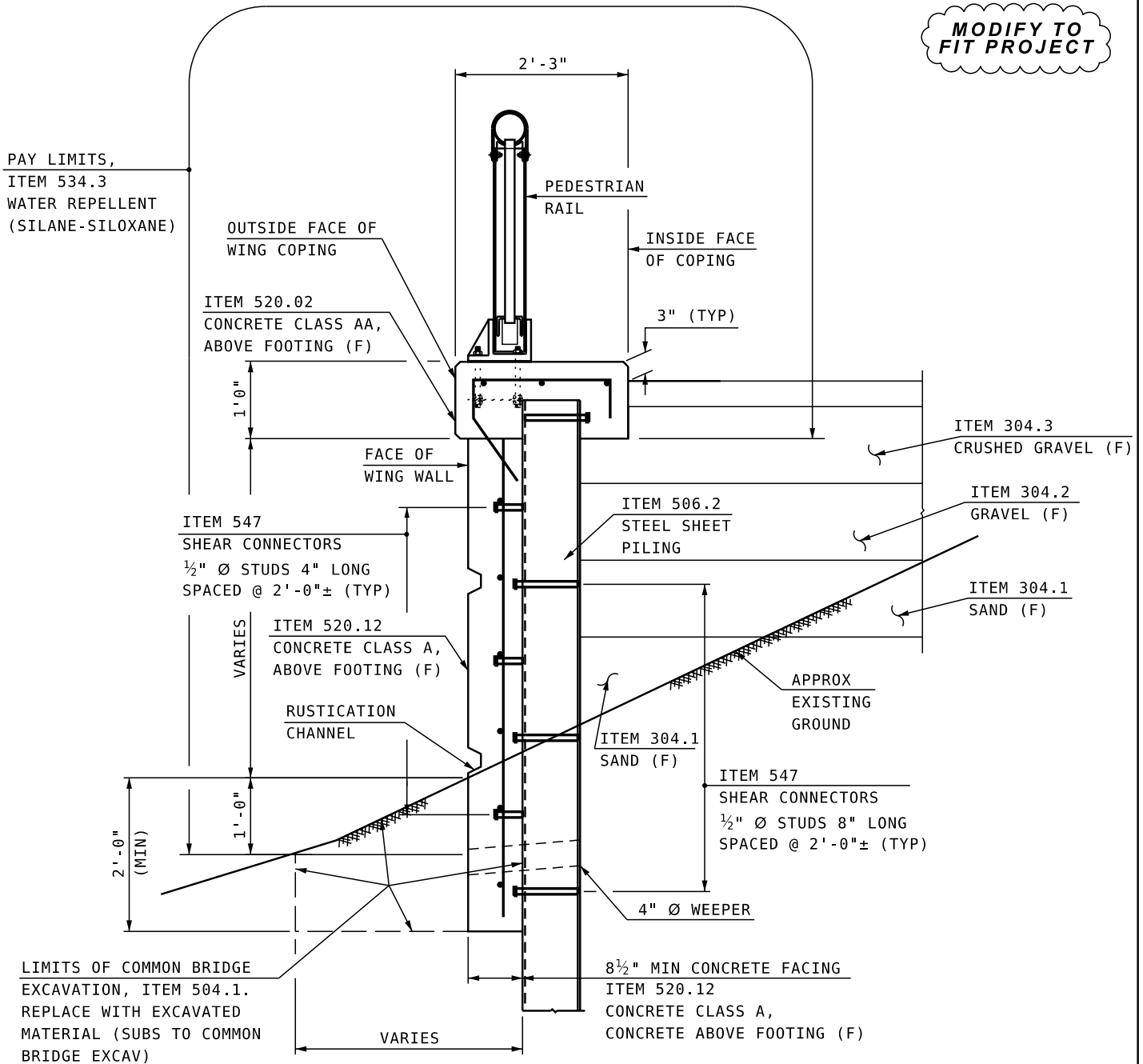

SHEET PILE RETAINING WALL WITH ARCHITECTURAL TREATMENT

NEW HAMPSHIRE DEPARTMENT OF TRANSPORTATION



BUREAU OF BRIDGE DESIGN



DESCRIPTION: **SUBSTRUCTURE DETAILS -
SHEET PILE WALL W/ MOMENT SLAB**

DATE REVISED:
1/11/2023

**MODIFY TO
FIT PROJECT**

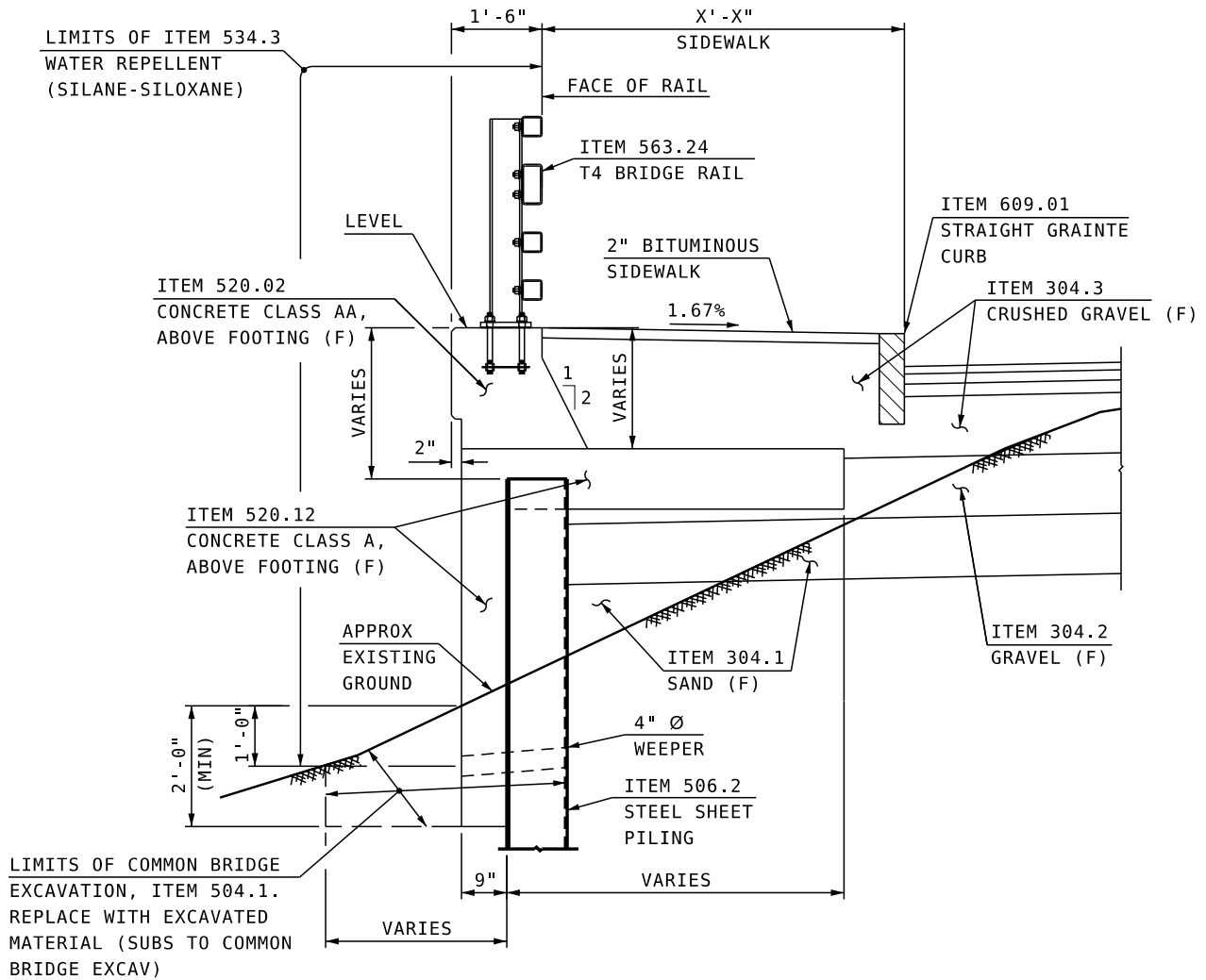

SHEET PILE RETAINING WALL WITH BRIDGE RAIL MOMENT SLAB

NEW HAMPSHIRE DEPARTMENT OF TRANSPORTATION



BUREAU OF BRIDGE DESIGN



DESCRIPTION: **SUBSTRUCTURE DETAILS -
SHEET PILE WALL W/ STONE FACING**

DATE REVISED:
7/31/2023

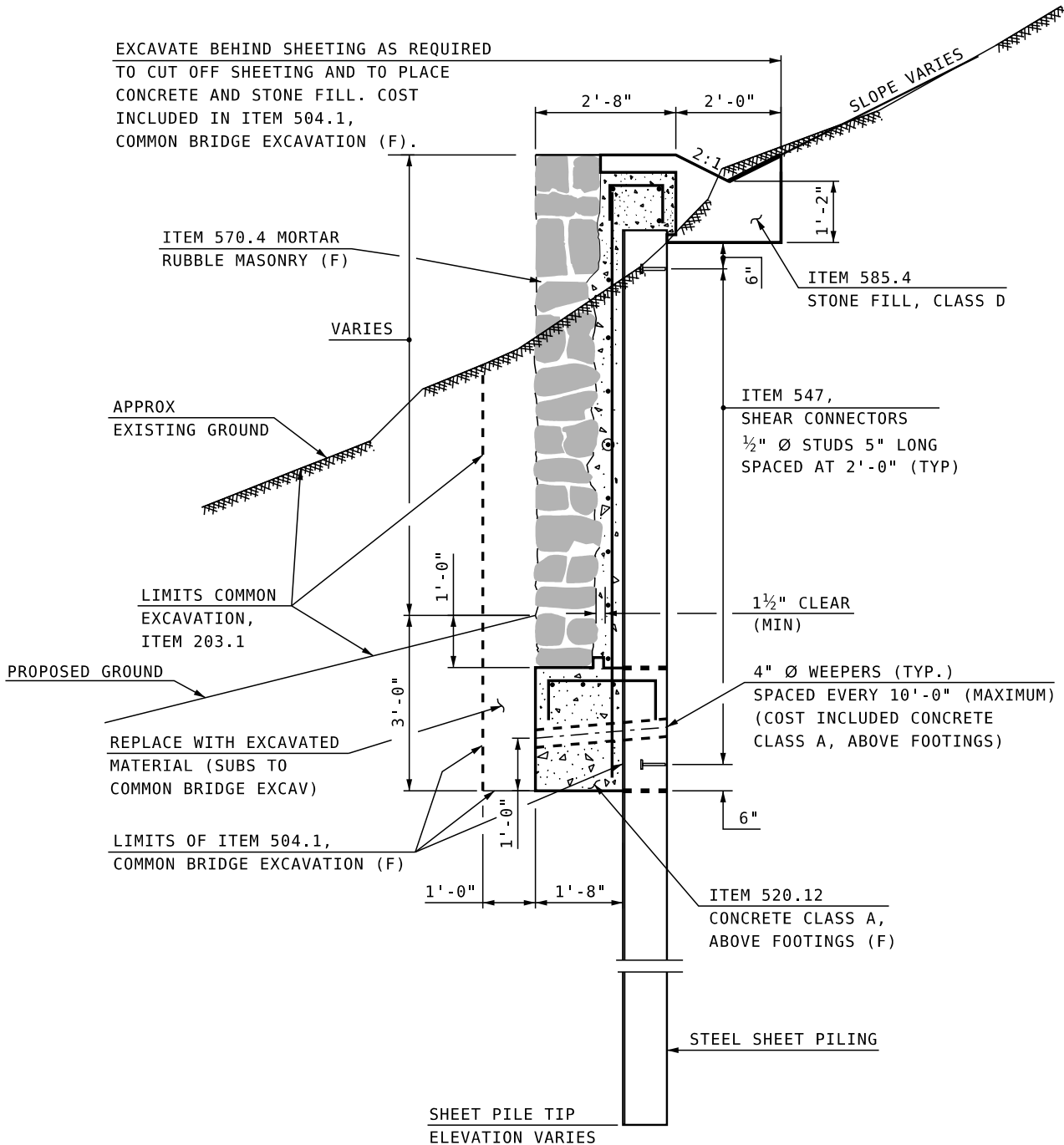

SHEET PILE RETAINING WALL WITH STONE FACING

MODIFY TO
FIT PROJECT