

TYPICAL ASSEMBLY DETAIL

PLAN VIEW

SCALE: 1" = 1'-0" (TYP)

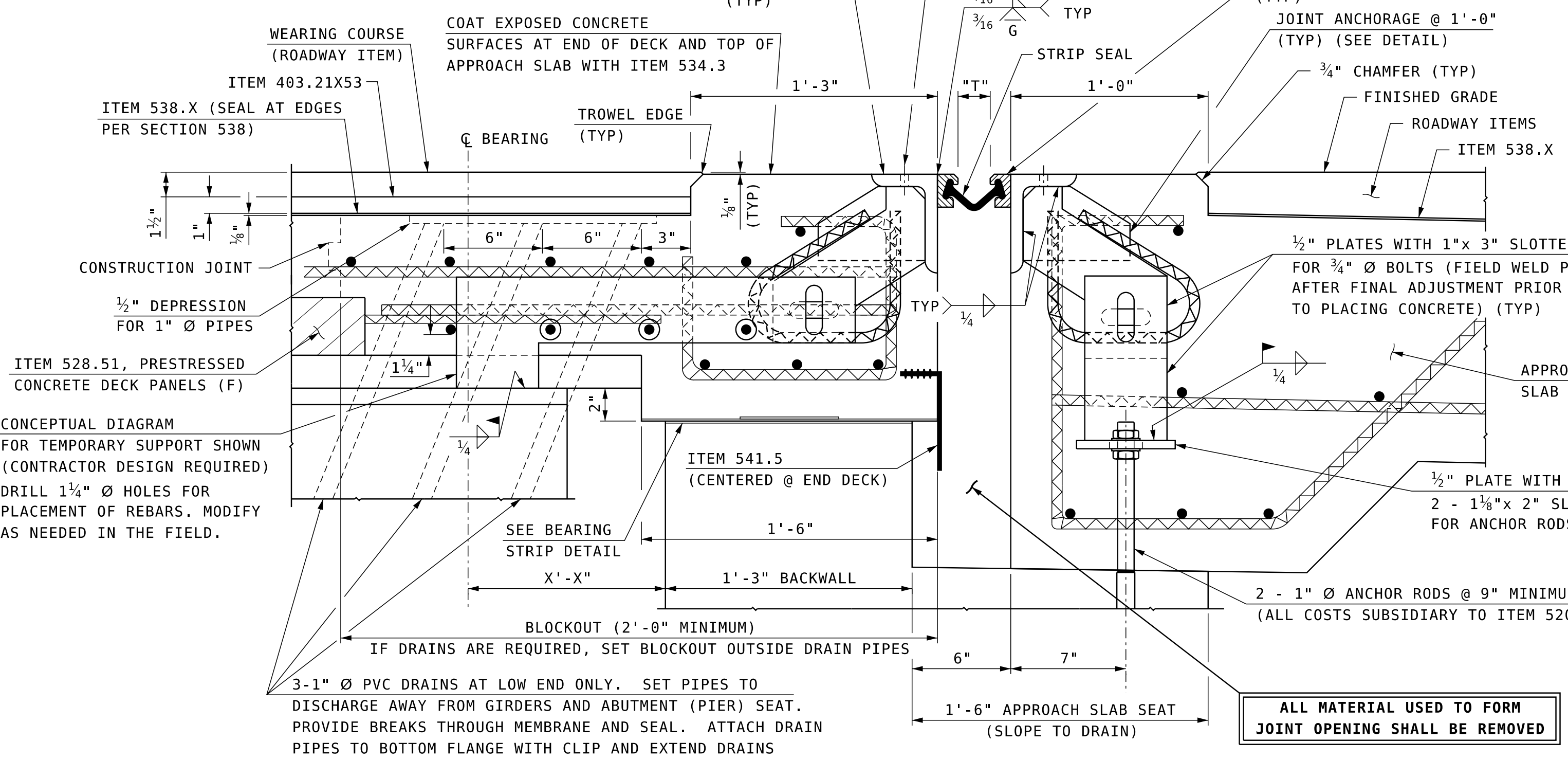

SECTION A-A

SCALE: 2" = 1'-0"

MODIFY SHEET AS REQUIRED TO PROJECT DETAILS (SKEW, PROFILE, PHASING, RAIL POST LOCATION, ALL PERTINENT DETAILS, ETC.). PROVIDE ADDITIONAL SHEETS AS REQUIRED.

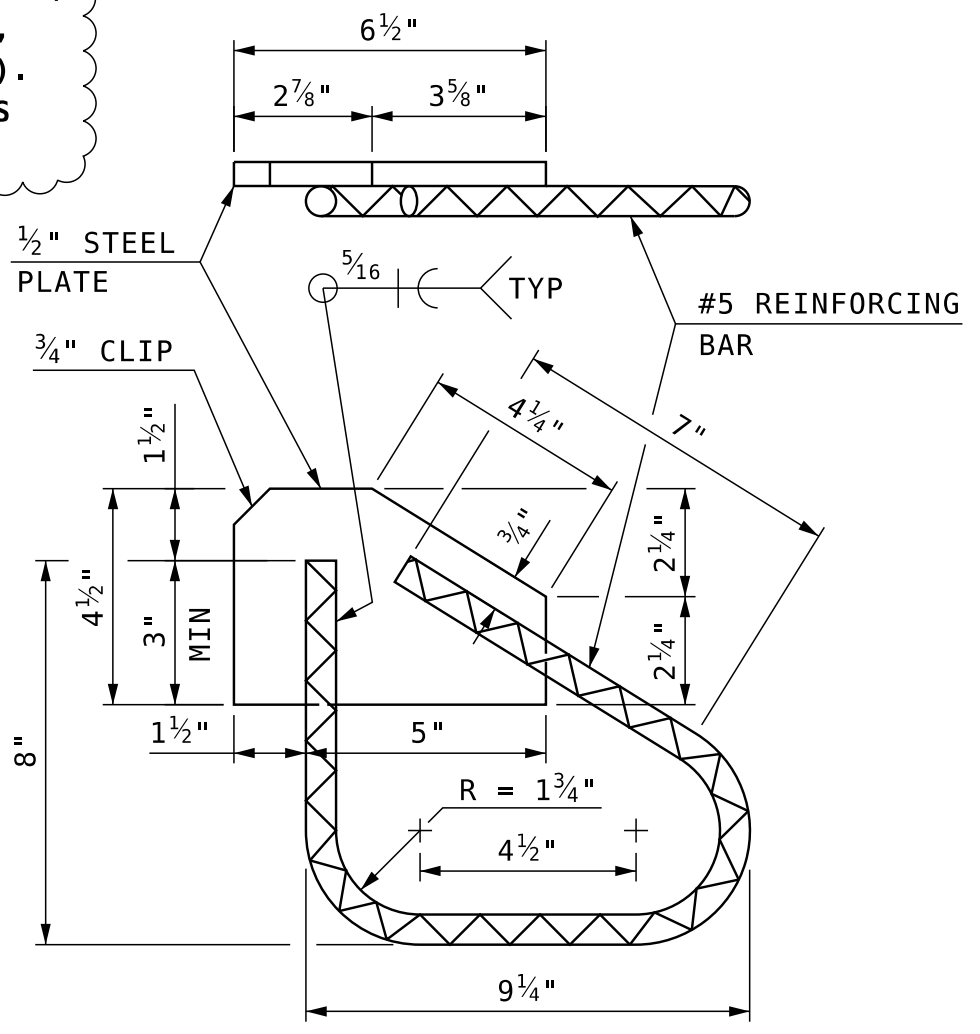

ANCHOR DETAIL (90° CROSSING)
SCALE: 3" = 1'-0"

EXPANSION JOINT NOTES

- ALL EXPANSION JOINT STEEL, INCLUDING ANCHORS, SHALL BE GALVANIZED. STEEL ANGLES SHALL BE ASTM A572 GRADE 50. MINOR STEEL PLATES MAY CONFORM TO ASTM A36. THE ENTIRE ASSEMBLY, INCLUDING STRIP SEAL, SHALL BE PAID FOR AS ITEM 561.1001, PREFABRICATED STRIP SEAL EXPANSION JOINT (F).
- SPLICES FOR STEEL ANGLES SHALL DEVELOP FULL STRENGTH.
- EXPANSION JOINT OPENING SHALL BE ADJUSTED TO TEMPERATURE ANTICIPATED PRIOR TO POURING DECK BLOCKOUT. FINAL SETTING IN THE FIELD SHALL BE DETERMINED BY THE CONTRACT ADMINISTRATOR. SEE TEMPERATURE ADJUSTMENT TABLE & NOTES.
- STRIP SEAL SHALL BE FURNISHED IN ONE CONTINUOUS LENGTH. NO SPLICES WILL BE ALLOWED. SEAL SHALL BE INSTALLED IN THE FIELD BY THE CONTRACTOR, IN ACCORDANCE WITH THE MANUFACTURER OF THE SEAL, USING AN APPROVED TOOL THAT WILL NOT DAMAGE THE SEAL.
- JOINT SUPPORT PLATES AND CURB PLATES SHALL BE SHOP WELDED TO EXPANSION JOINT STEEL AND SHALL BE NORMAL TO GRADE AFTER JOINT ASSEMBLY HAS BEEN ADJUSTED FOR ROADWAY CROSS-SLOPE AND GRADE. STEEL ANGLES AND EXTRUSIONS SHALL BE ASSEMBLED WITH A CONSTANT JOINT OPENING TO ENSURE PROPER PERFORMANCE AND WATER TIGHTNESS.
- THE EXPANSION JOINT ASSEMBLY SHALL BE INSTALLED ONLY AFTER BOTH ABUTMENTS HAVE BEEN BACKFILLED TO WITHIN 3'-0" OF FINISHED GRADE.
- IMMEDIATELY AFTER THE JOINT HAS BEEN SECURED TO THE STRUCTURAL STEEL AND BACKWALL, REMOVE SHIPPING DEVICES AND GRIND SMOOTH ANY WELDS ON EXPOSED SURFACES. REPAIR ANY DAMAGE TO GALVANIZED SURFACES IN ACCORDANCE WITH SECTION 550.2.
- PROTECT TOP OF EXPANSION JOINT DURING PLACEMENT OF CONCRETE AND BITUMINOUS PAVEMENT.
- THE STRIP SEAL HAS BEEN DESIGNED FOR A TOTAL FACTORED MOVEMENT OF XX INCHES. DESIGN INCLUDES MOVEMENT DUE TO TEMPERATURE, SKEW, SHRINKAGE AND MINIMUM INSTALLATION WIDTH. THE CONTRACTOR SHALL USE AN SE-400 SEAL BY WATSON BOWMAN (SHOWN) OR A2R-400 BY D.S. BROWN, AS NOTED IN THE OPL.
- ELEVATIONS SHOWN AT TOP OF ANGLES ARE 1/8" LOWER THAN PROPOSED FINISHED ROADWAY GRADE.
- NO "LOW PROFILE" STEEL EXTRUSIONS SHALL BE ALLOWED. SEE OPL FOR APPROVED PRODUCTS.
- PRIOR TO INSTALLING THE SEAL, ALL TEMPORARY FORM WORK SHALL BE REMOVED. STEEL ANGLES AND EXTRUSIONS SHALL BE MAINTAINED FREE FROM DIRT, WATER AND ANY OTHER LOOSE DEBRIS, WITH THE USE OF COMPRESSED AIR, TO ENSURE PROPER FIT OF THE SEAL. CARE SHALL BE TAKEN NOT TO DAMAGE GALVANIZED SURFACES.
- A TEMPORARY SEAL(S) SHALL BE INSTALLED PRIOR TO THE START OF THE WINTER MAINTENANCE PERIOD FOR ALL JOINT ASSEMBLIES OR PORTIONS THEREOF THAT WILL BE IN PLACE THROUGHOUT THE WINTER. ALL TEMPORARY SEALS SHALL BE REMOVED AND JOINT OPENINGS AND SUBSTRUCTURE SHALL BE CLEANED PRIOR TO INSTALLING THE FINAL SEAL. ALL COSTS SHALL BE SUBSIDIARY TO ITEM 561.1001.

SEE COMPRESSION SEAL DETAILS FOR EXAMPLE OF SIDEWALK PLATES

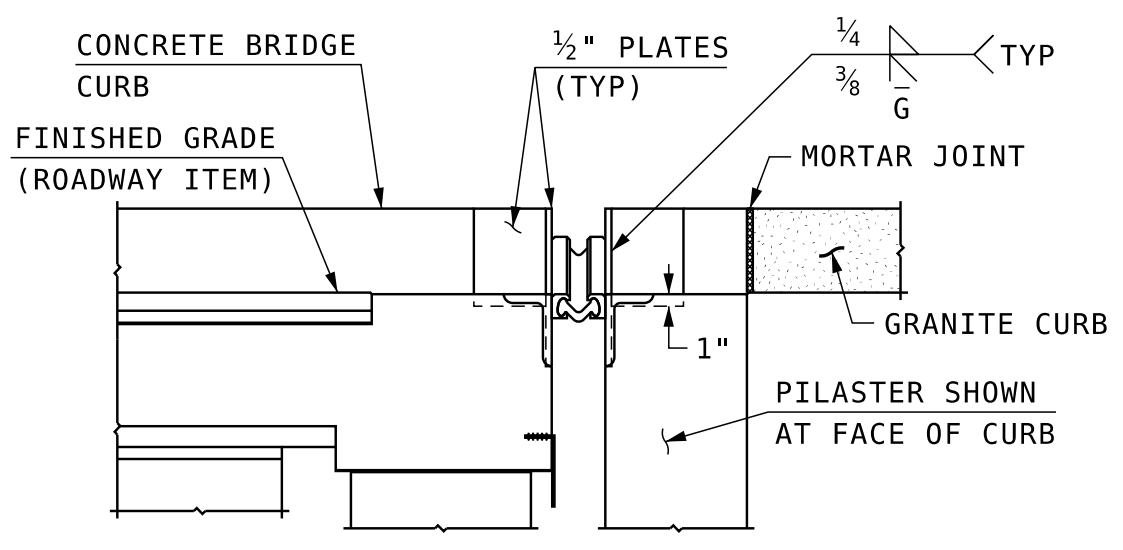

SECTION B-B

SCALE: 3/4" = 1'-0"

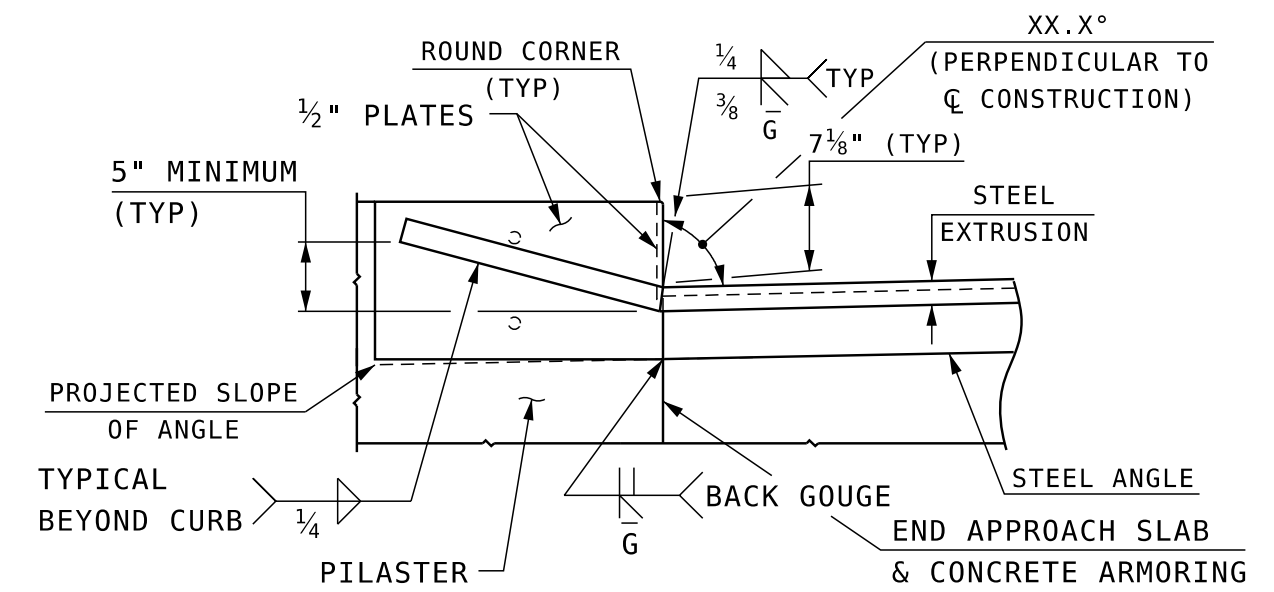

SECTION C-C

SCALE: 3/4" = 1'-0"

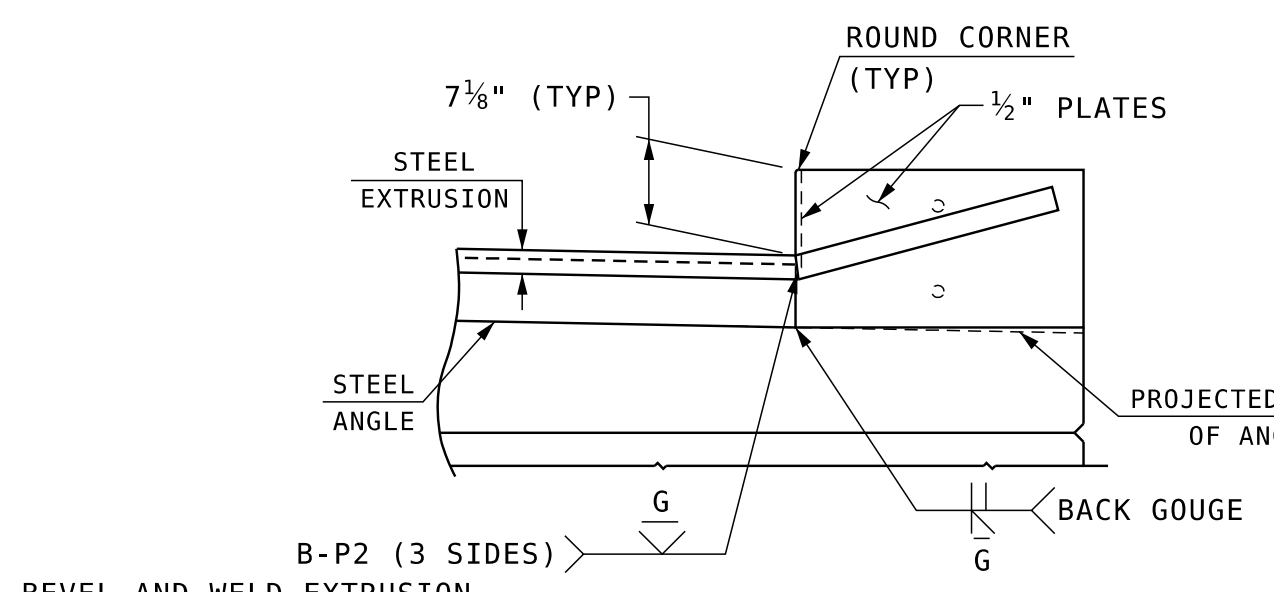

SECTION D-D

SCALE: 3/4" = 1'-0"

BEVEL AND WELD EXTRUSION. GRIND CONTOUR SMOOTH WHERE IN CONTACT WITH SEAL FOR A WATER TIGHT FIT. (TYP)

CONCEPTUAL DIAGRAM FOR TEMPORARY SUPPORT SHOWN (CONTRACTOR DESIGN REQUIRED) DRILL 1 1/4" Ø HOLES FOR PLACEMENT OF REBARS. MODIFY AS NEEDED IN THE FIELD.

DECK HAUNCH STRIP: BOND RUBBER BACKED SIDE TO TOP OF DECK STRIP FOR FULL LENGTH OF DECK STRIP SECTION

BEARING STRIPS (RUBBER BACKED UHMW-PE, 1/4" THICK MINIMUM, 3/8" MAXIMUM) (SEE QUALIFIED PRODUCTS LIST, SECTION 520, FOR MATERIALS AND BONDING AGENT) (ALL COSTS SUBSIDIARY TO ITEM 520.XXXX)

DECK STRIP: EMBED 1'-6" WIDE SECTION (RUBBER SIDE UP) INTO DECK HAUNCH FOR THE ENTIRE WIDTH OF DECK

BACKWALL STRIP: GRIND TOP OF BACKWALL TO A SMOOTH FLAT SURFACE AND BOND RUBBER BACKED SIDE OF 1'-3" WIDE SECTION TO TOP OF BACKWALL FOR THE ENTIRE LENGTH OF DECK AND BACKWALL CONTACT AREA

BEARING STRIP DETAIL

NOT TO SCALE

TEMPERATURE ADJUSTMENT NOTES

- "T" DIMENSIONS ARE PERPENDICULAR TO FACE OF BACKWALL.
- MINIMUM "T" WIDTH FOR SEAL INSTALLATION = X" (APPROXIMATELY 65°F OR LESS).
- VALUES IN THE TEMPERATURE ADJUSTMENT TABLE ARE FOR SETTING THE EXPANSION JOINT ASSEMBLY IMMEDIATELY PRIOR TO POURING THE DECK BLOCKOUT.

TEMPERATURE ADJUSTMENT TABLE	
TEMPERATURE	"T"
20°F	X
35°F	X
50°F	X
65°F	X
80°F	X
95°F	X

STATE OF NEW HAMPSHIRE DEPARTMENT OF TRANSPORTATION * BUREAU OF BRIDGE DESIGN					
TOWN		BRIDGE NO.		STATE PROJECT	
LOCATION					
STRIP SEAL EXPANSION JOINT					BRIDGE SHEET
REVISIONS AFTER PROPOSAL	BY	DATE	BY	DATE	OF
DESIGNED	NHDOT	2/89	CHECKED	NHDOT	2/89
DRAWN	PJP	4/13	CHECKED	ABH	4/13
QUANTITIES	XXX	XX/XX	CHECKED	XXX	XX/XX
ISSUE DATE	2/89	FEDERAL PROJECT NO.	SHEET NO.	TOTAL SHEETS	
REV. DATE	7/31/23				

SUBDIRECTORY	.DGN LOCATOR	SHEET SCALE
EXPANSION JOINTS	Strip-Seal-Bkwall-Panel	AS NOTED