

# NEW HAMPSHIRE DEPARTMENT OF TRANSPORTATION



## BUREAU OF BRIDGE DESIGN



DESCRIPTION: SUBSTRUCTURE DETAILS -  
TYPICAL WING SECTION (STRAIGHT BACK)

DATE REVISED:  
7/31/2023

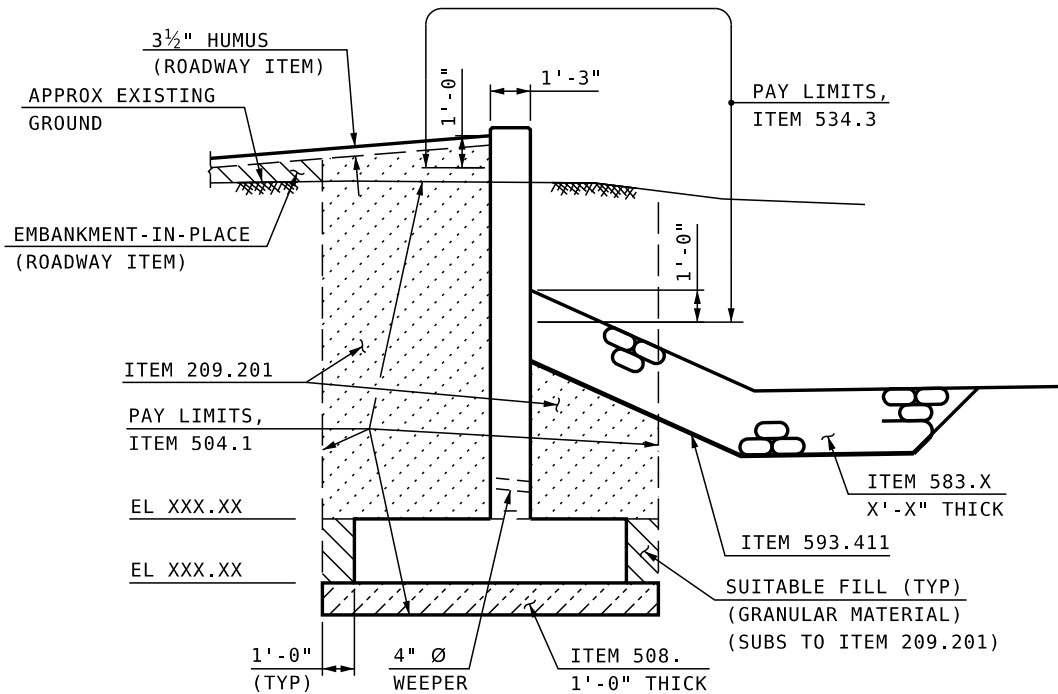

### TYPICAL WING SECTION (STRAIGHT BACK)

MODIFY TO  
FIT PROJECT

NEW HAMPSHIRE DEPARTMENT OF TRANSPORTATION



BUREAU OF BRIDGE DESIGN



DESCRIPTION: SUBSTRUCTURE DETAILS -  
TYPICAL WING SECTION

DATE REVISED:  
7/31/2023

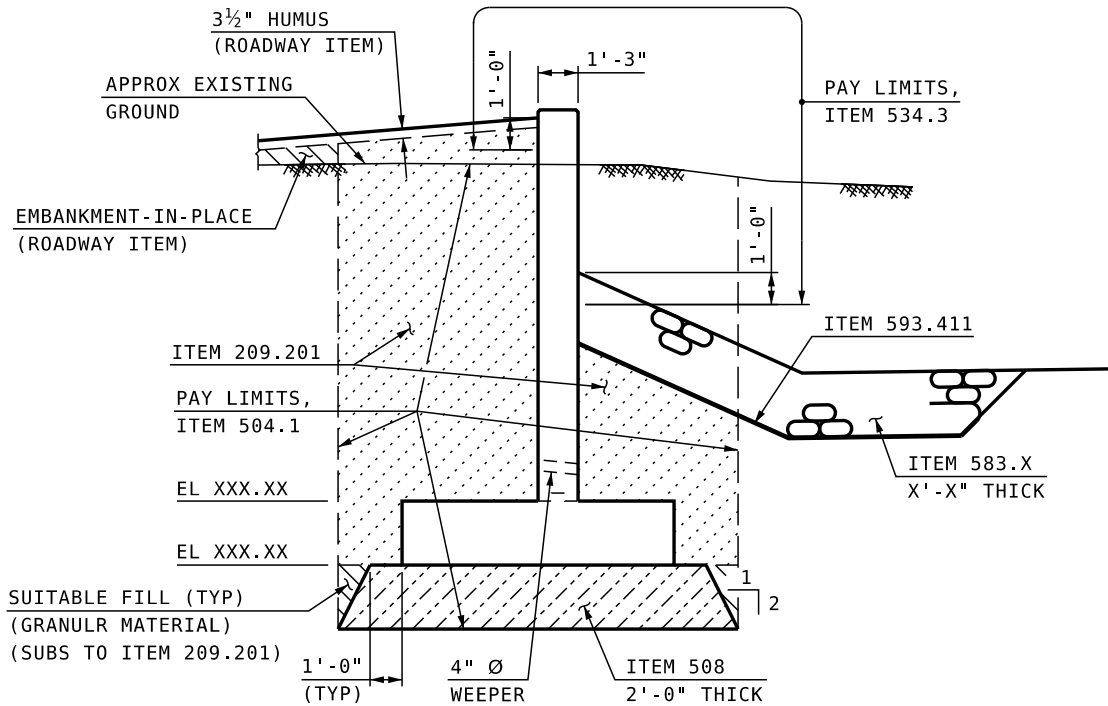

**TYPICAL WING SECTION**  
**GREATER THAN 1 FT STRUCTURAL FILL**

MODIFY TO  
FIT PROJECT

# NEW HAMPSHIRE DEPARTMENT OF TRANSPORTATION



## BUREAU OF BRIDGE DESIGN



DESCRIPTION: SUBSTRUCTURE DETAILS -  
TYPICAL REINFORCED WING SECTION

DATE REVISED:  
7/31/2023

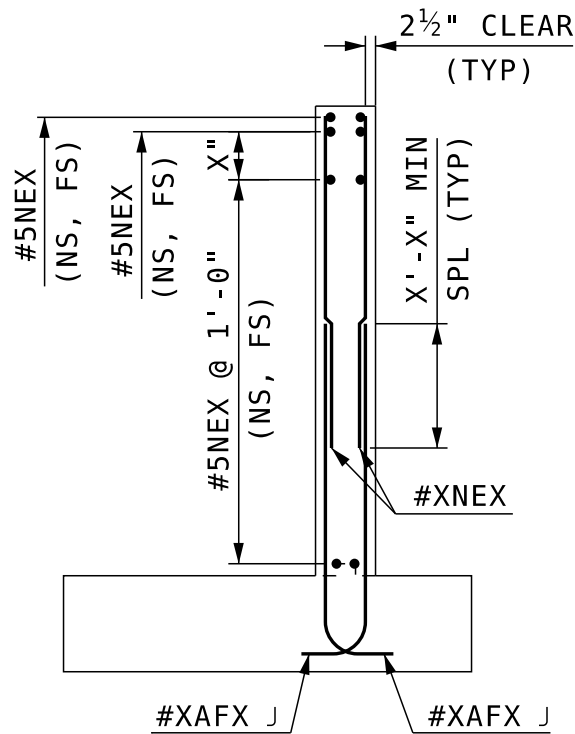

## TYPICAL REINFORCED WING SECTION

MODIFY TO  
FIT PROJECT

# NEW HAMPSHIRE DEPARTMENT OF TRANSPORTATION



## BUREAU OF BRIDGE DESIGN



DESCRIPTION: SUBSTRUCTURE DETAILS -  
TYPICAL WING SECTION (BATTERED BACK)

DATE REVISED:  
7/31/2023

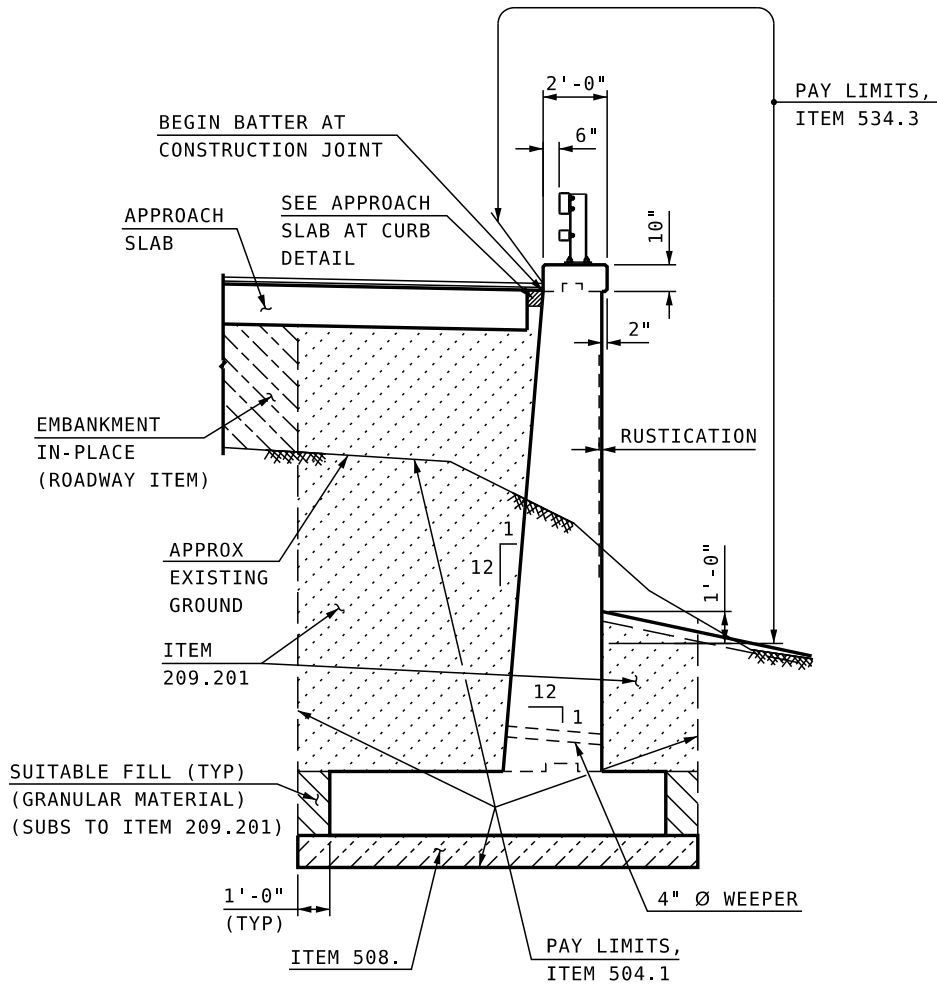

### TYPICAL WING SECTION (BATTERED BACK)

MODIFY TO  
FIT PROJECT

# NEW HAMPSHIRE DEPARTMENT OF TRANSPORTATION



## BUREAU OF BRIDGE DESIGN



DESCRIPTION: SUBSTRUCTURE DETAILS -  
TYPICAL REINFORCED WING SECTION (BATTERED BACK)

DATE REVISED:  
7/31/2023

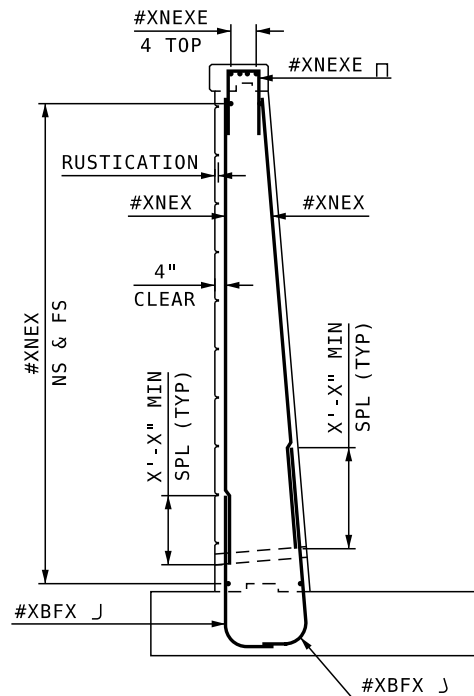

### TYPICAL REINFORCED WING SECTION (BATTERED BACK & RUSTIFICATION)

NOTE:  
USE A BAR CALLOUT THAT CORRESPONDS TO THE BAR LOCATION:  
EX: BAR CALLOUT OF NE IS FOR NORTHEAST WING  
BAR CALLOUT OF BF IS FOR ABUTMENT B FOOTING

MODIFY TO  
FIT PROJECT

# NEW HAMPSHIRE DEPARTMENT OF TRANSPORTATION



## BUREAU OF BRIDGE DESIGN



DESCRIPTION:

**SUBSTRUCTURE DETAILS -  
U-BACK WING WITH BUTTERFLY**

DATE REVISED:

7/31/2023

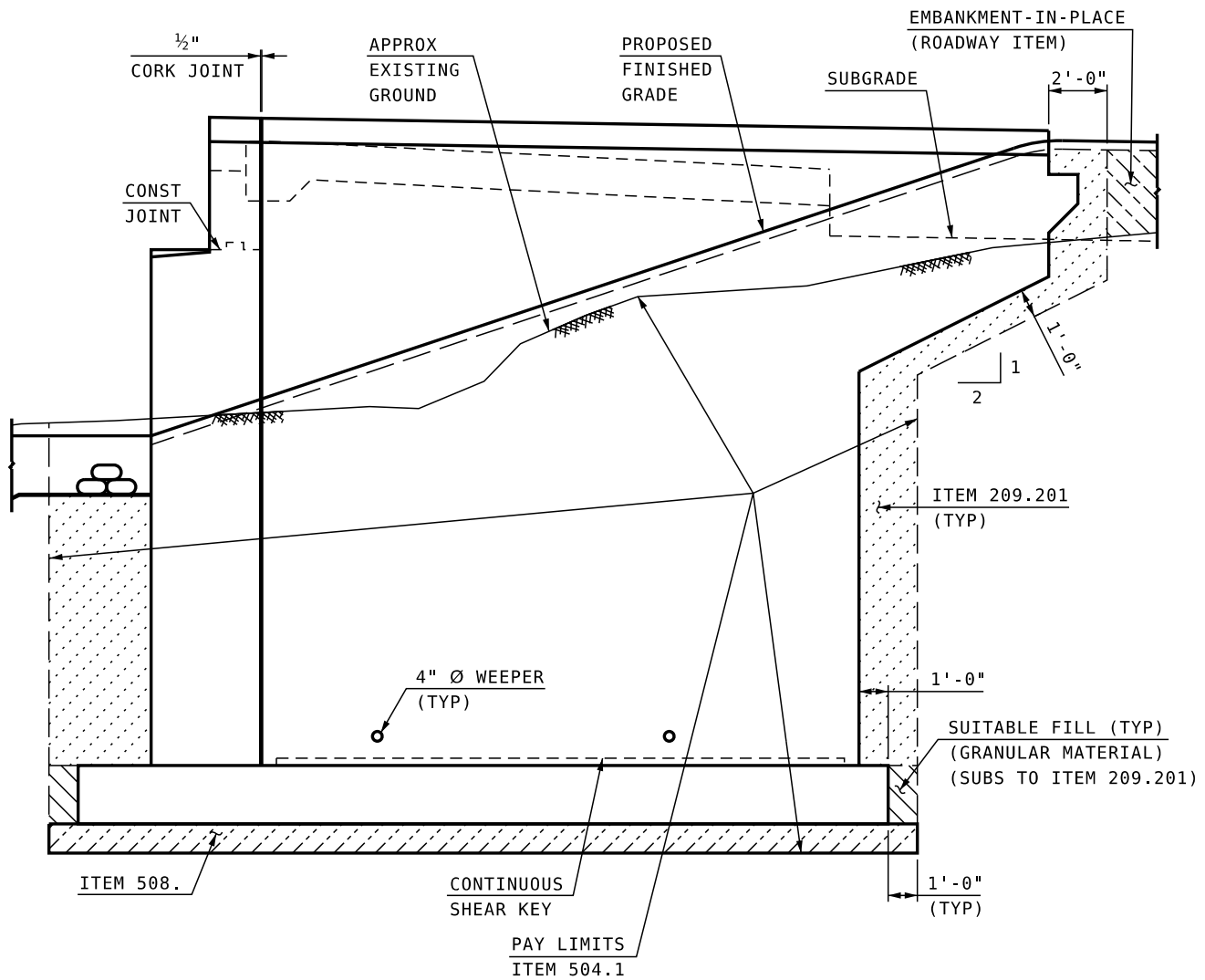

**U-BACK WING W/ BUTTERFLY  
ELEVATION**

MODIFY TO  
FIT PROJECT

# NEW HAMPSHIRE DEPARTMENT OF TRANSPORTATION



## BUREAU OF BRIDGE DESIGN



DESCRIPTION: SUBSTRUCTURE DETAILS -  
U-BACK WING W/ BUTTERFLY STEPPED ON LEDGE

DATE REVISED:  
7/31/2023

**MODIFY TO  
FIT PROJECT**

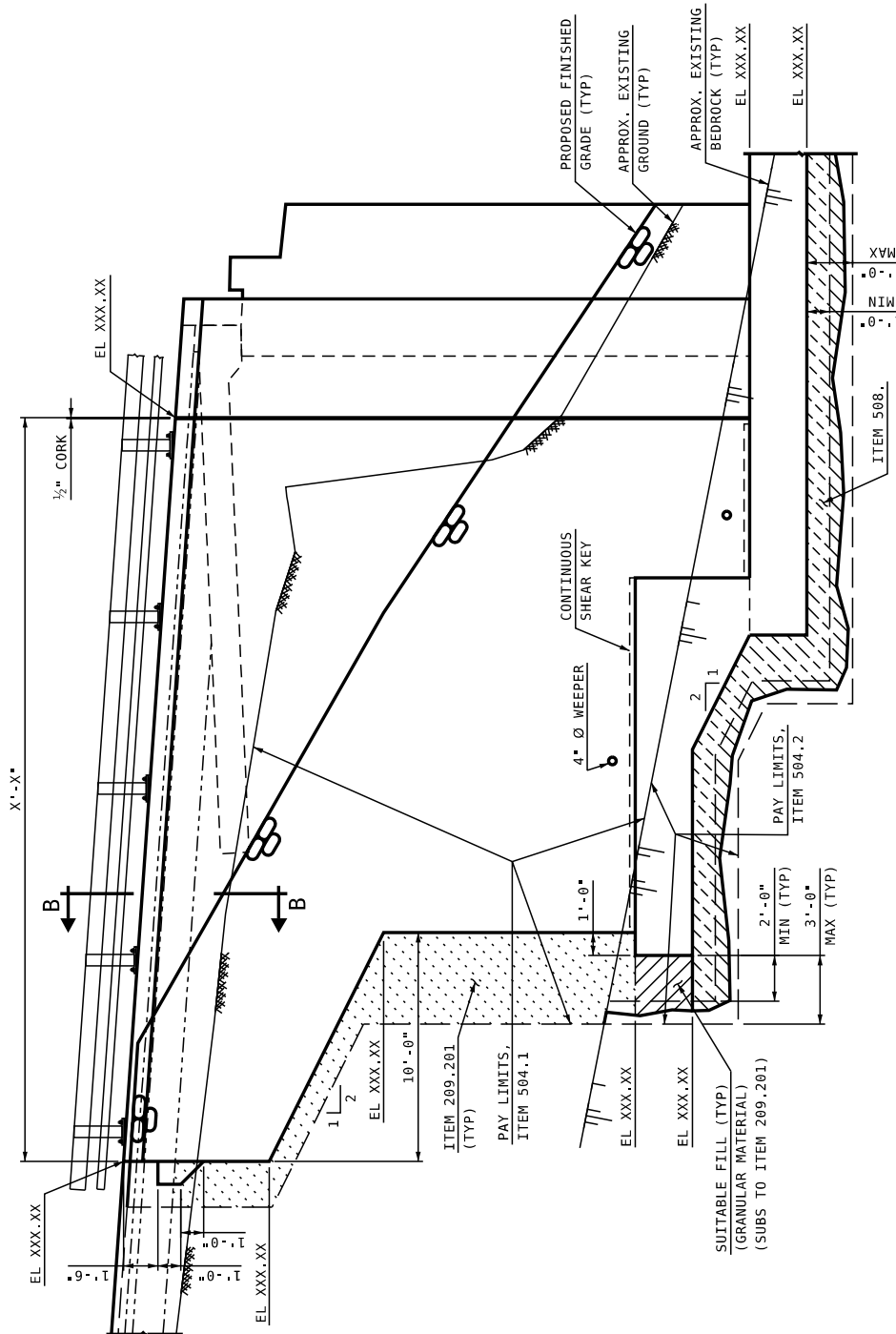

**U-BACK WING W/BUTTERFLY AND STEPPED ON LEDGE  
ELEVATION**

# NEW HAMPSHIRE DEPARTMENT OF TRANSPORTATION



## BUREAU OF BRIDGE DESIGN



DESCRIPTION: SUBSTRUCTURE DETAILS -  
U-BACK BATTERED WING PLAN

DATE REVISED:  
7/31/2023

MODIFY TO  
FIT PROJECT

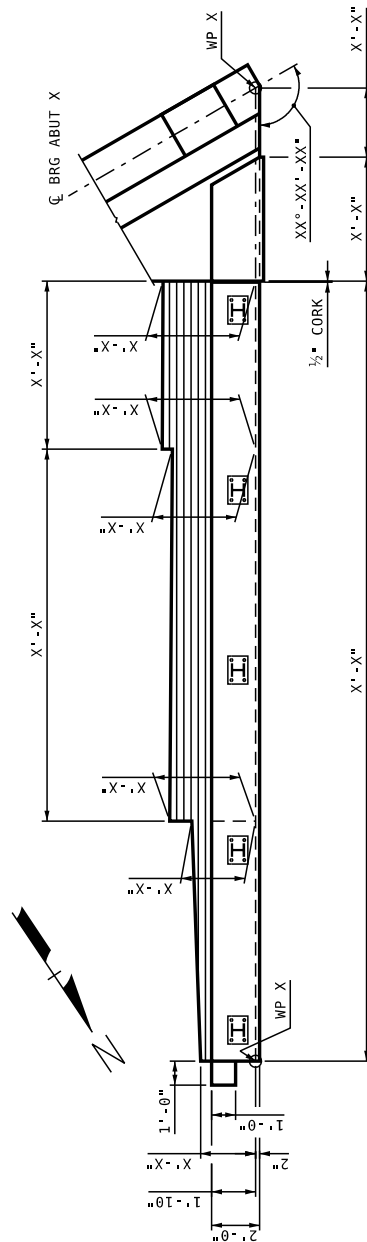

**U-BACK BATTERED WING PLAN**



# NEW HAMPSHIRE DEPARTMENT OF TRANSPORTATION



## BUREAU OF BRIDGE DESIGN



DESCRIPTION: **SUBSTRUCTURE DETAILS -  
U-BACK WING SECTION W/ SIDEWALK**

DATE REVISED:  
7/31/2023

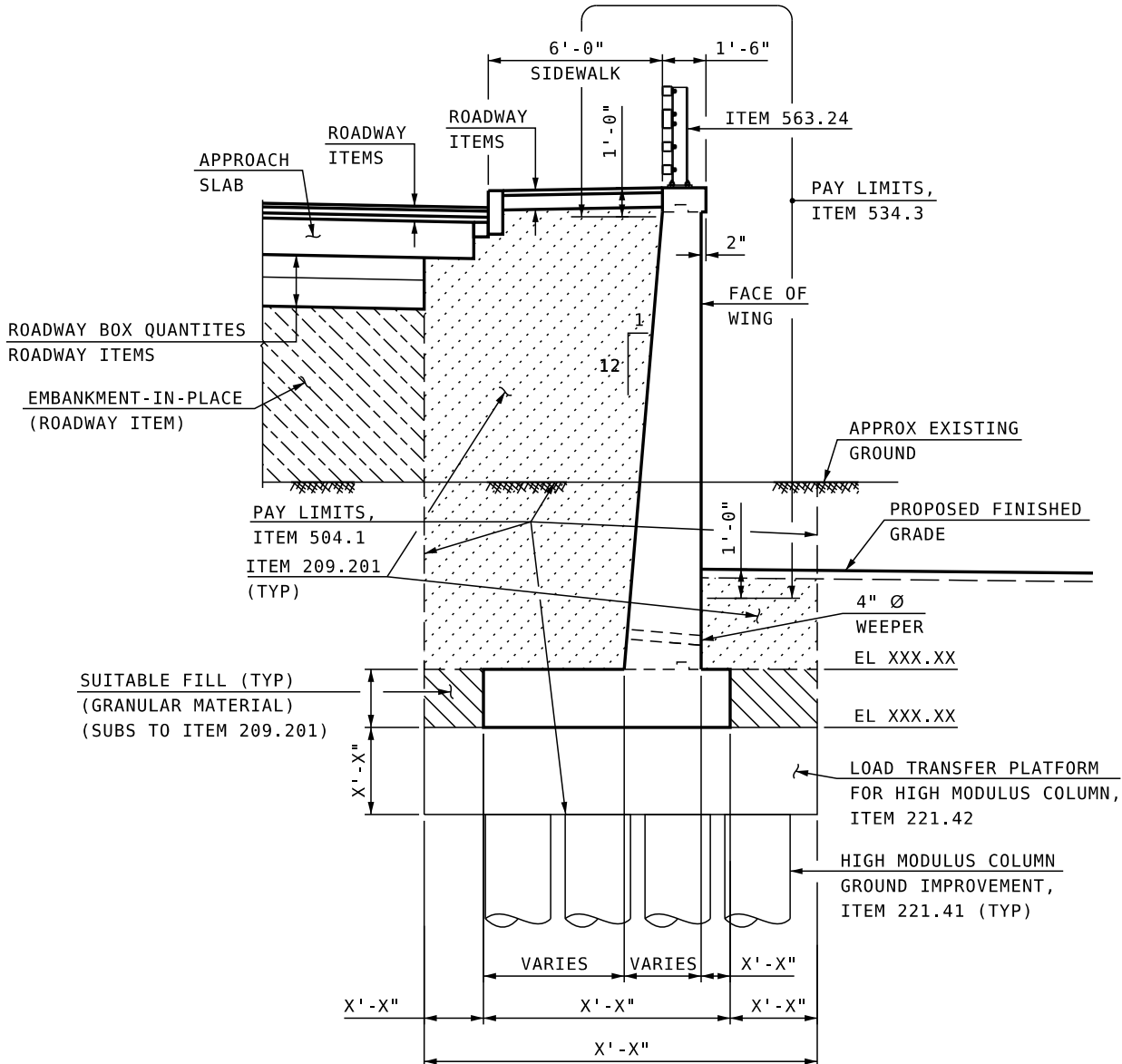

**U-BACK WING SECTION WITH SIDEWALK**

**MODIFY TO  
FIT PROJECT**

# NEW HAMPSHIRE DEPARTMENT OF TRANSPORTATION



## BUREAU OF BRIDGE DESIGN



DESCRIPTION:

SUBSTRUCTURE DETAILS -  
WING ELEVATION (MASONRY)

DATE REVISED:

7/31/2023

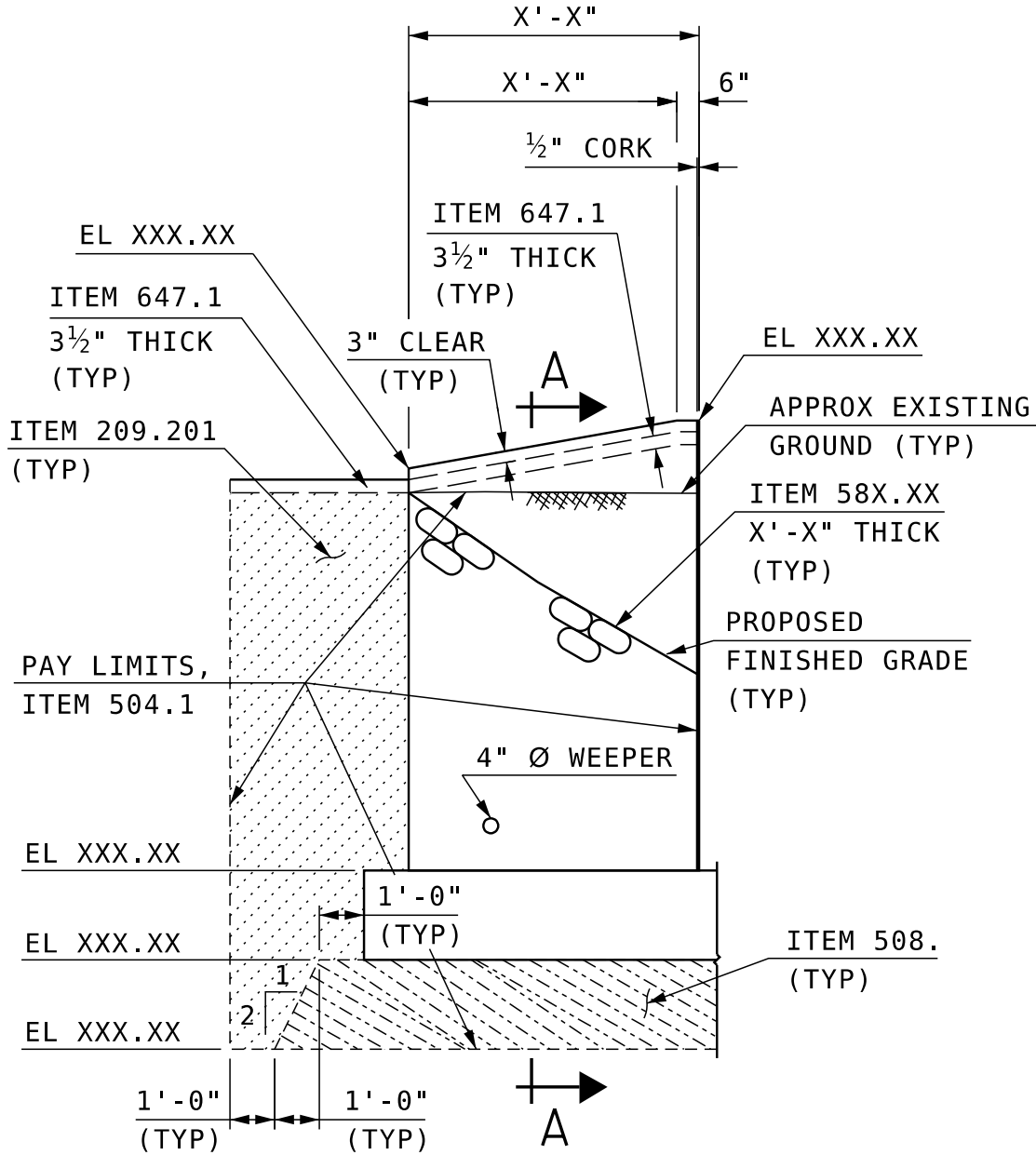

## WING ELEVATION (MASONRY)

MODIFY TO  
FIT PROJECT

# NEW HAMPSHIRE DEPARTMENT OF TRANSPORTATION



## BUREAU OF BRIDGE DESIGN



DESCRIPTION: SUBSTRUCTURE DETAILS -  
WING ELEVATION (REINFORCEMENT)

DATE REVISED:  
7/31/2023

14 #5SE1 @ 1'-0" (7 NS, 7 FS)  
(SPL W/#5AF10 J NS  
& #5AF11 J FS)

2 #5SE4  
(1 NS, 1 FS)

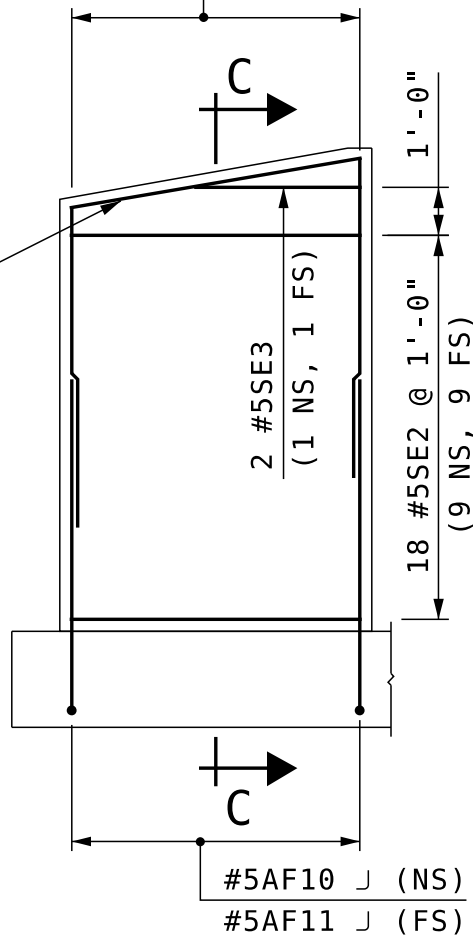

## WING ELEVATION (REINFORCEMENT)

MODIFY TO  
FIT PROJECT

# NEW HAMPSHIRE DEPARTMENT OF TRANSPORTATION



## BUREAU OF BRIDGE DESIGN



DESCRIPTION:

DECK, PILASTER, AND  
WING JOINT DETAIL

DATE REVISED:

7/31/2023

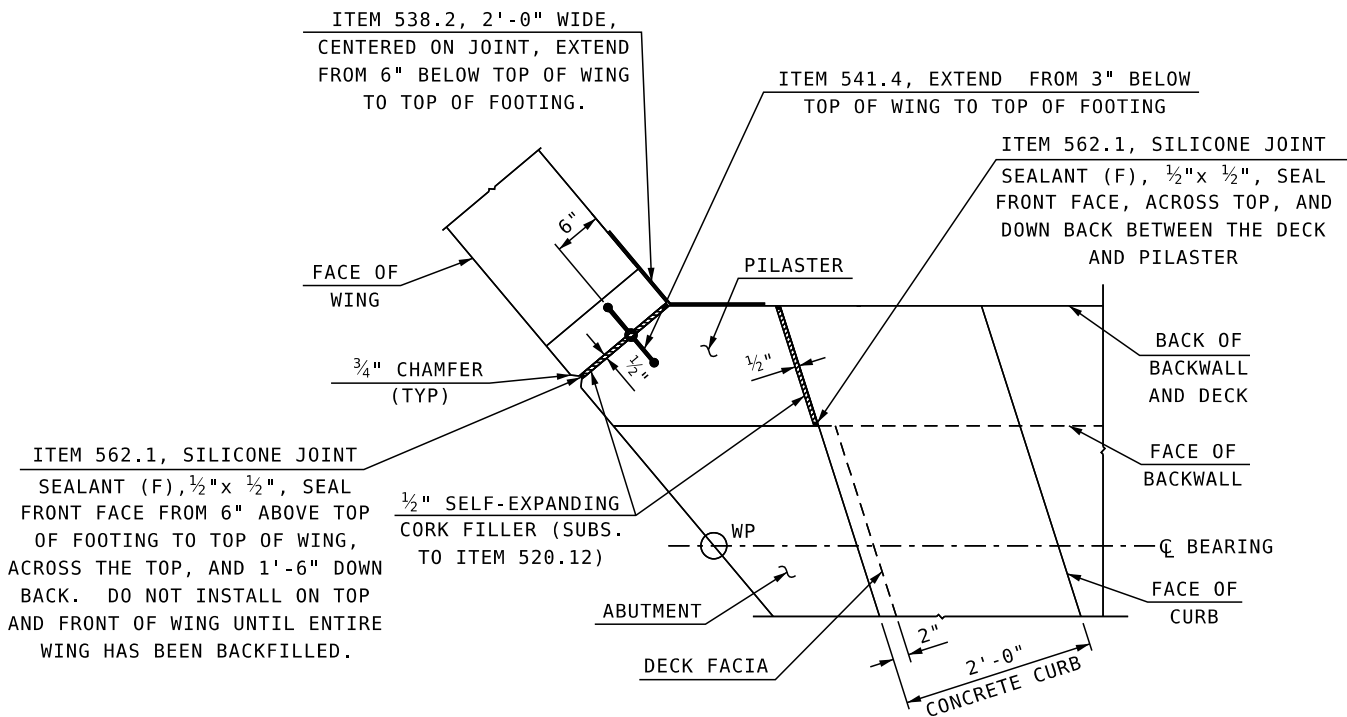

### DECK, PILASTER, AND WING JOINT DETAIL

MODIFY TO  
FIT PROJECT